

GN 607-NI

Indexing plungers

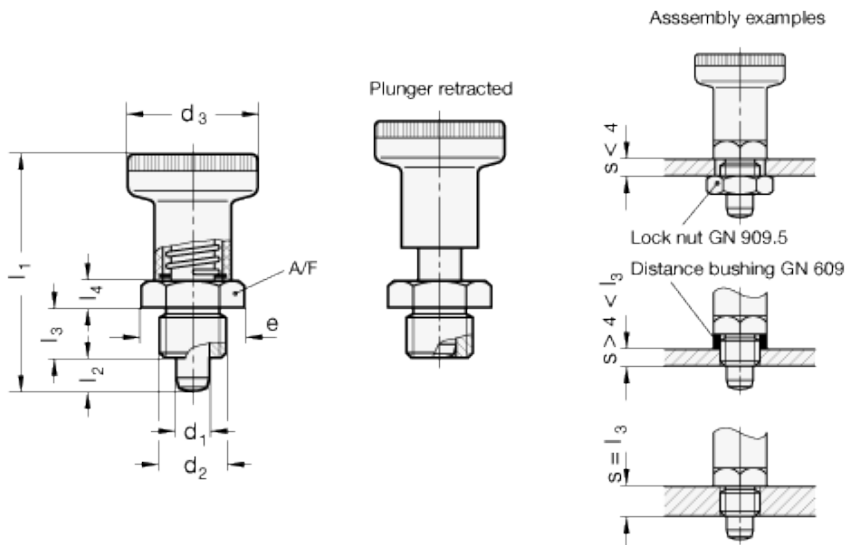

INOX
Stainless Steel



technical informations

Threaded body

AISI 303 stainless steel.

Plunger

Nickel-plated AISI 303 stainless steel. Suggested matching hole in H7 tolerance.

Locking nut

AISI 304 stainless steel.

"Push/Pull" knurled knob

High resilience polyamide based (PA) technopolymer, black colour, matte finish. Resistant to solvents, oils, greases and other chemical agents.

Standard executions available

- Version A: with knob, without locking nut.
- Version AK: with knob and locking nut, ISO 8675.

Accessories on request (For sufficient quantities)

GN 609.5 AISI 303 stainless steel distance bushings are available for making up for the length of the threading in case the plunger is assembled on thin sheets.

Features and applications

GN 607-NI indexing plungers have compact dimensions and are used on thin metal sheets. AISI 303 stainless steel, thanks to its high resistance to corrosion, allows the application of these indexing plungers on machines and equipment in those sectors where laws or particular hygienic, climatic and environmental factors make it mandatory to use corrosion resistant materials.

Standard Elements	Main dimensions								Spring pressure in N \approx		Axial holding force in N	Weight g	
	d ₁ -0.02/-0.04	d ₂	d ₃	e	l ₁	l ₂ min.	l ₃ -0.15	l ₄ A/F	Preload	Max. load			
GN 607-6-A-NI	6	M12x1.5	25	19.6	45	6	10	5	17	18	22	400	34
GN 607-8-A-NI	8	M16x1.5	31	21.9	54	8	12	6	19	24	28	500	60
GN 607-6-AK-NI	6	M12x1.5	31	21.9	54	8	12	6	19	24	28	400	43
GN 607-8-AK-NI	8	M16x1.5	31	21.9	54	8	12	6	19	24	28	500	76



ELESA and GANTER models all rights reserved in accordance with the law. Always mention the source when reproducing our drawings.

STANDARD MACHINE ELEMENTS WORLDWIDE