

GN 605-NI

Grub screws with ball terminal

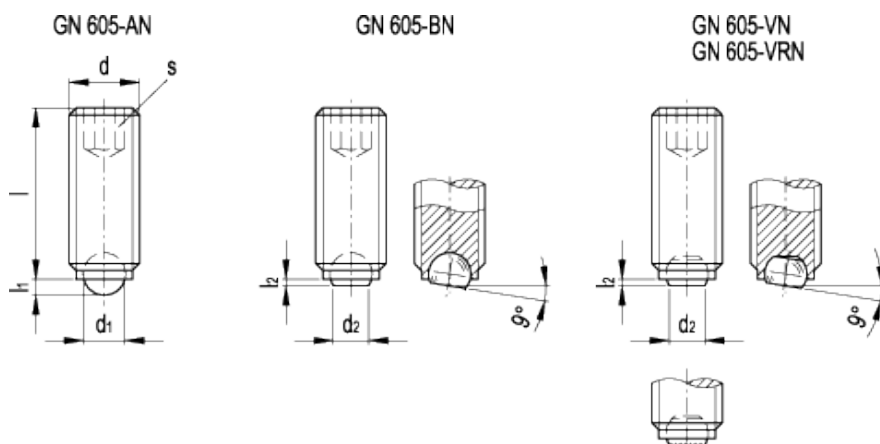

INOX
Stainless Steel



technical informations

Material

AISI 304 stainless steel, hexagon socket head.

Ball

Hardened stainless steel.

- Execution AN: ball for applications requiring a single point contact.
 - Execution BN: reversible flat-faced ball for fitting non-parallel surfaces.
 - Execution VN: non-reversible flat-faced ball.
 - Execution VRN: non-reversible knurled flat-faced ball.
- Maximum ball plane inclination for flat-faced balls = 9°.

Features and applications

GN 605-NI grub screws with ball terminal are suitable for locking or supporting pieces to be machined.

AISI 304 stainless steel, thanks to its high resistance to corrosion, allows the application of these grub screws on machines and equipment in those sectors where laws or particular hygienic, climatic and environmental factors make it mandatory to use corrosion resistant materials.

Standard Elements	Main dimensions							Weight
	Description	d	l	l ₁₋	l ₂₋	d ₁	d ₂	
GN 605-M4-6-AN	M4	6	0.8	-	2.5	-	2	1
GN 605-M4-10-AN	M4	10	0.8	-	2.5	-	2	1
GN 605-M4-16-AN	M4	16	0.8	-	2.5	-	2	1
GN 605-M5-8-AN	M5	8	0.9	-	3	-	2.5	1
GN 605-M5-12-AN	M5	12	0.9	-	3	-	2.5	1
GN 605-M5-20-AN	M5	20	0.9	-	3	-	2.5	2
GN 605-M4-6-BN	M4	6	-	0.4	-	1.8	2	1
GN 605-M4-10-BN	M4	10	-	0.4	-	1.8	2	1
GN 605-M4-16-BN	M4	16	-	0.4	-	1.8	2	1
GN 605-M5-8-BN	M5	8	-	0.5	-	2	2.5	1
GN 605-M5-12-BN	M5	12	-	0.5	-	2	2.5	1
GN 605-M5-20-BN	M5	20	-	0.5	-	2	2.5	2
GN 605-M6-10-*	M6	10	1.4	0.6	4	3.2	3	2
GN 605-M6-16-*	M6	16	1.4	0.6	4	3.2	3	3
GN 605-M6-20-*	M6	20	1.4	0.6	4	3.2	3	3
GN 605-M6-25-*	M6	25	1.4	0.6	4	3.2	3	4
GN 605-M8-10-*	M8	10	1.7	0.7	5.5	4.2	4	3
GN 605-M8-12-*	M8	12	1.7	0.7	5.5	4.2	4	3
GN 605-M8-20-*	M8	20	1.7	0.7	5.5	4.2	4	6
GN 605-M8-25-*	M8	25	1.7	0.7	5.5	4.2	4	8
GN 605-M8-30-*	M8	30	1.7	0.7	5.5	4.2	4	9
GN 605-M10-12-*	M10	12	2.3	0.8	7	5.7	5	5
GN 605-M10-16-*	M10	16	2.3	0.8	7	5.7	5	7
GN 605-M10-20-*	M10	20	2.3	0.8	7	5.7	5	9
GN 605-M10-25-*	M10	25	2.3	0.8	7	5.7	5	11
GN 605-M10-35-*	M10	35	2.3	0.8	7	5.7	5	16
GN 605-M12-16-*	M12	16	2.8	0.9	8	7.1	6	10
GN 605-M12-20-*	M12	20	2.8	0.9	8	7.1	6	13
GN 605-M12-30-*	M12	30	2.8	0.9	8	7.1	6	20
GN 605-M12-40-*	M12	40	2.8	0.9	8	7.1	6	28
GN 605-M16-20-*	M16	20	4	1.5	12	9.7	8	22
GN 605-M16-25-*	M16	25	4	1.5	12	9.7	8	28
GN 605-M16-35-*	M16	35	4	1.5	12	9.7	8	41
GN 605-M16-50-*	M16	50	4	1.5	12	9.7	8	48

* Complete the description of the standard item needed by adding the index of ball execution: AN (full ball), BN (reversible flat-faced ball), VN (non reversible flat-faced ball), VRN (non reversible knurled flat-faced ball).



ELESA and GANTER models all rights reserved in accordance with the law. Always mention the source when reproducing our drawings.

STANDARD MACHINE ELEMENTS WORLDWIDE