

GN 605

Grub screws with ball terminal

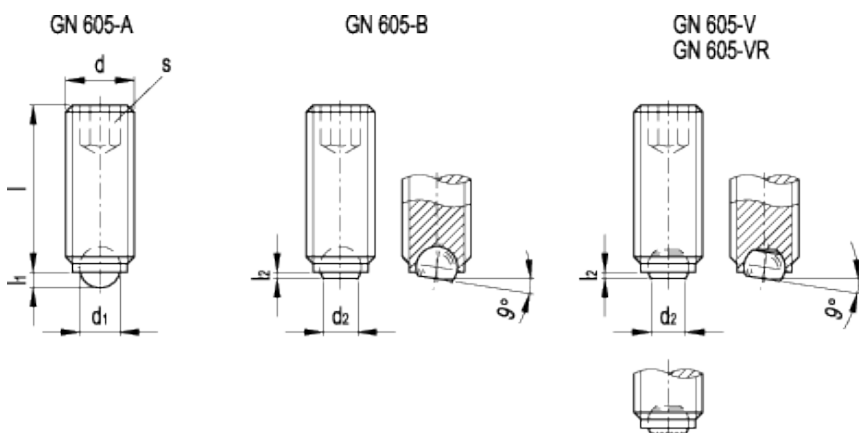

technical informations

Material

Black-oxide steel, hexagon socket head.

Ball

Hardened steel.

- Execution A: ball for applications requiring a single point contact.
- Execution B: reversible flat-faced ball for fitting non-parallel surfaces.
- Execution V: non-reversible flat-faced ball.
- Execution VR: non-reversible knurled flat-faced ball.

Maximum ball plane inclination for flat-faced balls = 9°.

Applications

GN 605 grub screws with ball terminal are suitable for locking or supporting pieces to be machined.

Standard Elements	Main dimensions							Weight
	Description	d	l	l _{1~}	d ₁	d ₂	s	
GN 605-M4-6-A	M4	6	0.8	-	2.5	-	2	1
GN 605-M4-10-A	M4	10	0.8	-	2.5	-	2	1
GN 605-M4-16-A	M4	16	0.8	-	2.5	-	2	1
GN 605-M5-8-A	M5	8	0.9	-	3	-	2.5	1
GN 605-M5-12-A	M5	12	0.9	-	3	-	2.5	1
GN 605-M5-20-A	M5	20	0.9	-	3	-	2.5	2
GN 605-M4-6-B	M4	6	-	0.4	-	1.8	2	1
GN 605-M4-10-B	M4	10	-	0.4	-	1.8	2	1
GN 605-M4-16-B	M4	16	-	0.4	-	1.8	2	1
GN 605-M5-8-B	M5	8	-	0.5	-	2	2.5	1
GN 605-M5-12-B	M5	12	-	0.5	-	2	2.5	1
GN 605-M5-20-B	M5	20	-	0.5	-	2	2.5	2
GN 605-M6-10-*	M6	10	1.4	0.6	4	3.2	3	2
GN 605-M6-16-*	M6	16	1.4	0.6	4	3.2	3	3
GN 605-M6-20-*	M6	20	1.4	0.6	4	3.2	3	3
GN 605-M6-25-*	M6	25	1.4	0.6	4	3.2	3	4
GN 605-M8-10-*	M8	10	1.7	0.7	5.5	4.2	4	3
GN 605-M8-12-*	M8	12	1.7	0.7	5.5	4.2	4	3
GN 605-M8-20-*	M8	20	1.7	0.7	5.5	4.2	4	6
GN 605-M8-25-*	M8	25	1.7	0.7	5.5	4.2	4	8
GN 605-M8-30-*	M8	30	1.7	0.7	5.5	4.2	4	9
GN 605-M10-12-*	M10	12	2.3	0.8	7	5.7	5	5
GN 605-M10-16-*	M10	16	2.3	0.8	7	5.7	5	7
GN 605-M10-20-*	M10	20	2.3	0.8	7	5.7	5	9
GN 605-M10-25-*	M10	25	2.3	0.8	7	5.7	5	11
GN 605-M10-35-*	M10	35	2.3	0.8	7	5.7	5	16
GN 605-M12-16-*	M12	16	2.8	0.9	8	7.1	6	10
GN 605-M12-20-*	M12	20	2.8	0.9	8	7.1	6	13
GN 605-M12-30-*	M12	30	2.8	0.9	8	7.1	6	20
GN 605-M12-40-*	M12	40	2.8	0.9	8	7.1	6	28
GN 605-M16-20-*	M16	20	4	1.5	12	9.7	8	22
GN 605-M16-25-*	M16	25	4	1.5	12	9.7	8	28
GN 605-M16-35-*	M16	35	4	1.5	12	9.7	8	41
GN 605-M16-50-*	M16	50	4	1.5	12	9.7	8	48

* Complete the description of the standard item needed by adding the index of ball execution: A (full ball), B (reversible flat-faced ball), V (non reversible flat-faced ball), VR (non reversible knurled flat-faced ball).



ELESA and GANTER models all rights reserved in accordance with the law. Always mention the source when reproducing our drawings.

STANDARD MACHINE ELEMENTS WORLDWIDE