

GN 598.5

Fold-away handles

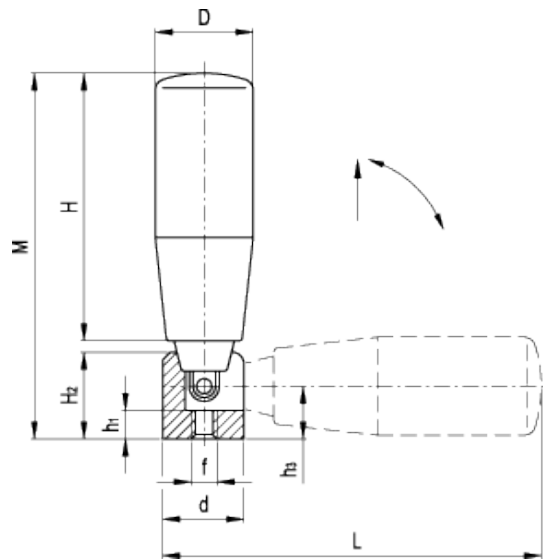

INOX
Stainless Steel



technical informations

Material

Black phenolic based (PF) Duroplast. Resistant to solvents, oils, greases and other chemical agents.

Stud

AISI 303 stainless steel.

Features and applications

Handle pivots freely during operation: a system of coaxial bushes compensates return spring load. A fold-away mechanism with compression spring locks the handle in both end positions.

GN 598.5 fold-away handles are suitable when the handle must be withdrawn during automatic operations for safety reasons or for lack of space.

Stainless steel, thanks to its high resistance to corrosion, allows the application of these fold-away handles on machines and equipment in those sectors where laws or particular hygienic, climatic and environmental factors make it mandatory to use corrosion resistant materials.

Standard Elements	Main dimensions							Mounting hole		Weight
Description	H	L	M	D	H ₂	d	h ₃	f	h ₁	g
GN 598.5-KU-23	65	90	87	23	19.5	20	10.5	M6	6	107
GN 598.5-KU-26	80	105	102	26	19.5	20	10.5	M6	6	139
GN 598.5-KU-28	90	119	118	28	26	26	16	M8	10	220



STANDARD MACHINE ELEMENTS WORLDWIDE