

GN 506.2

Dowels for T-slots with guide and no-slip device

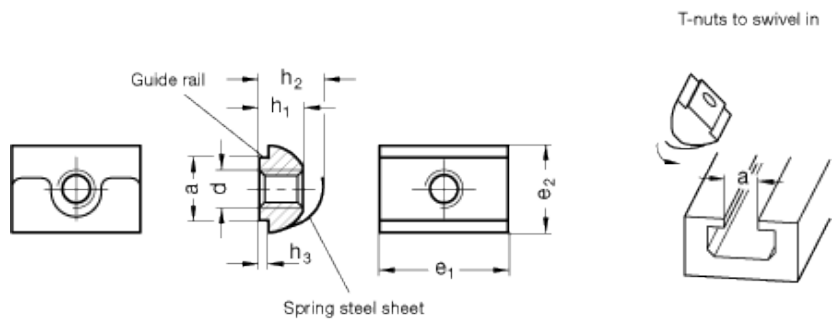

technical informations

Material

Zinc-plated steel.

Spring washer

AISI 301 stainless steel, spot-welded.

Features and applications

T-Nuts GN 506.2 can be turned into position, i.e. they can be inserted at any point along the slot.

The spring washer prevents the nut from inadvertently being displaced inside the slot, which is particularly advantageous if the profile rail is arranged vertically. The outstanding feature of this design is that different slot heights can be bridged.

As an example, T-Nuts GN 506.2 can be used to fit hinges to commercially available extrusion rails.

Standard Elements	Main dimensions							Sloth width	Weight
Description	a	d	e ₁	e ₂	h ₁	h ₂	h ₃ -0.1	a	g
GN 506.2-8-M4	8 _{±0.1}	M4	16	11.5	5.8	8.5	1	8	10
GN 506.2-8-M5	8 _{±0.1}	M5	16	11.5	5.8	8.5	1	8	5
GN 506.2-8-M6	8 _{±0.1}	M6	16	11.5	5.8	8.5	1	8	5
GN 506.2-8-M8	8 _{±0.1}	M8	16	11.5	5.8	8.5	1	8	10
GN 506.2-10-M5	10 -0.1/-0.3	M5	20.5	13.8	5.2	10.2	1.5	10	8
GN 506.2-10-M6	10 -0.1/-0.3	M6	20.5	13.8	5.2	10.2	1.5	10	10
GN 506.2-10-M8	10 -0.1/-0.3	M8	20.5	13.8	5.2	10.2	1.5	10	7



STANDARD MACHINE ELEMENTS WORLDWIDE