

GN 477

Clamp mountings

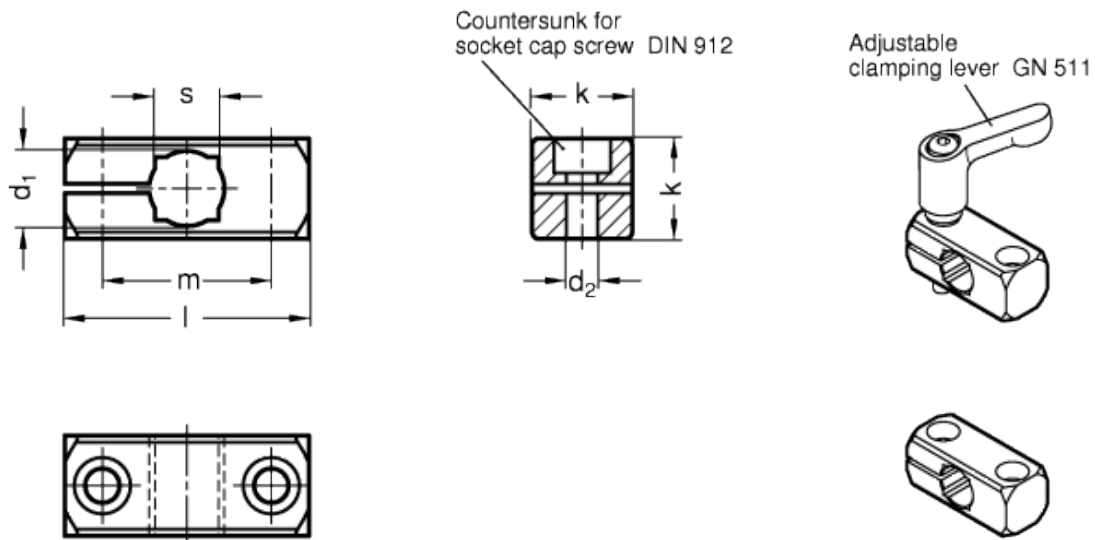

technical informations

Material

Aluminium.

Finish

- Version MT: matte, ground.
- Version ELS: anodised, black.

Features and applications

The clamp mountings GN 477 have no thread. Fixing or clamping is made via two threads on the attachment side. The bore spacing m of the clamp mountings GN 477 is matched with the foot clamp mountings GN 473 and the flanged bolts GN 480.

Accessories

Clamping kits [GN 511](#) (clamping handles GN 300.1 with distance bushing)

Standard Elements	Main dimensions						Clamping kits	Weight
Description	d ₁ Bore B for shaft tol. h11	k	d ₂ for screw	Length l	m	s Square V	for d ₃	g
GN 477-B8-MT	B8	14	M 4	31.5	22	-	GN 511-M4-20	11
GN 477-B10-MT	B10	16	M 5	38	27	8	GN 511-M5-25	18
GN 477-B12-MT	B12	16	M 5	38	27	10	GN 511-M5-25	37
GN 477-B15-MT	B15	20	M 6	45	32	12	GN 511-M6-25	40
GN 477-B16-MT	B16	20	M 6	45	32	-	GN 511-M6-25	29
GN 477-B20-MT	B20	25	M 6	50	36	16	GN 511-M6-32	52
GN 477-B8-ELS	B8	14	M 4	31.5	22	-	GN 511-M4-20	11
GN 477-B10-ELS	B10	16	M 5	38	27	8	GN 511-M5-25	18
GN 477-B12-ELS	B12	16	M 5	38	27	10	GN 511-M5-25	20
GN 477-B15-ELS	B15	20	M 6	45	32	12	GN 511-M6-25	31
GN 477-B16-ELS	B16	20	M 6	45	32	-	GN 511-M6-25	29
GN 477-B20-ELS	B20	25	M 6	50	36	16	GN 511-M6-32	52



STANDARD MACHINE ELEMENTS WORLDWIDE