

GN 414.1

Indexing plungers

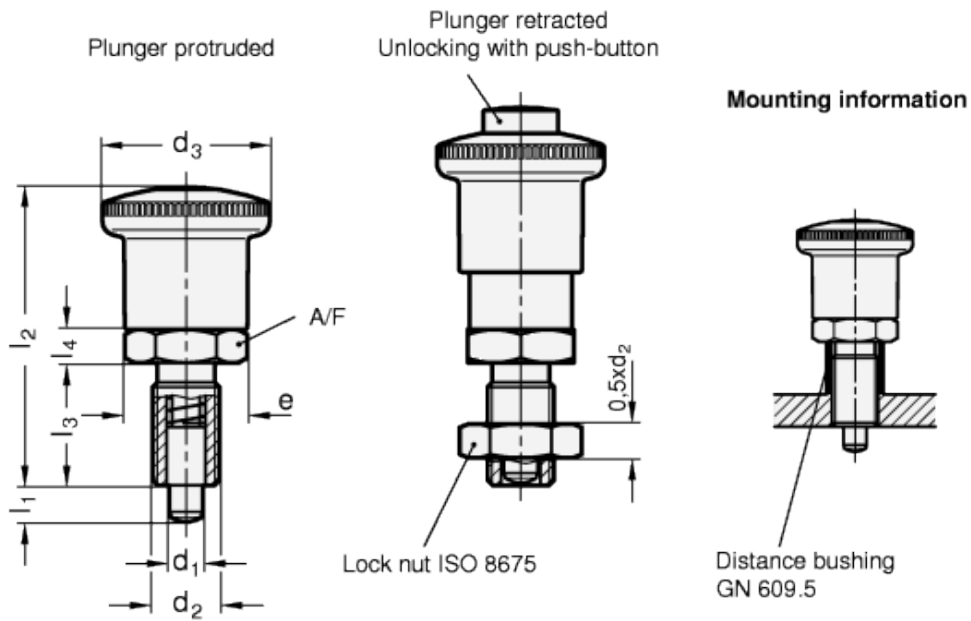

technical informations

Specification

Types

- Type A: without lock nut
- Type AK: with lock nut

Steel

- blackened
- Plunger hardened

Knob Plastic

Technopolymer (Polyamide PA)

- black matt finish
- not removable
- black-grey, RAL 7021, matt

Push-button
 Technopolymer (Polyacetal POM)
 red, RAL 3000, matt

Information

Indexing plungers GN 414.1 with click-type safety lock are used when the plunger pin is to be briefly prevented from protruding. When the pin is retracted to its end position, the button engages with a clearly audible click.

The safety lock can be unlocked only by exerting axial pressure on the red safety pushbutton, with the plunger pin then returning to its starting position by spring force.

Standard Elements	Main dimensions									Spring load in N \approx		Weight	
	Description	d ₁	l _{1 min.}	d ₂	d ₃	e	l _{2 ~}	l ₃	l ₄	A/F	initial		end
GN 414.1-6-6-A	6	6	M12x1.5	28	21.9	53.5	22	6	19		6.5	19	-
GN 414.1-6-9-A	6	9	M12x1.5	28	21.9	53.5	22	6	19		6	25	-
GN 414.1-8-8-A	8	8	M16x1.5	28	21.9	59.5	26	8	19		8.5	26	-
GN 414.1-8-12-A	8	12	M16x1.5	28	21.9	59.5	26	8	19		8.5	28	-
GN 414.1-10-12-A	10	12	M16x1.5	28	21.9	59.5	26	8	19		9.5	30	-
GN 414.1-6-6-AK	6	6	M12x1.5	28	21.9	53.5	22	6	19		6.5	19	-
GN 414.1-6-9-AK	6	9	M12x1.5	28	21.9	53.5	22	6	19		6	25	-
GN 414.1-8-8-AK	8	8	M16x1.5	28	21.9	59.5	26	8	19		8.5	26	-
GN 414.1-8-12-AK	8	12	M16x1.5	28	21.9	59.5	26	8	19		8.5	28	-
GN 414.1-10-12-AK	10	12	M16x1.5	28	21.9	59.5	26	8	19		9.5	30	-



STANDARD MACHINE ELEMENTS WORLDWIDE