

GN 355

Levelling elements

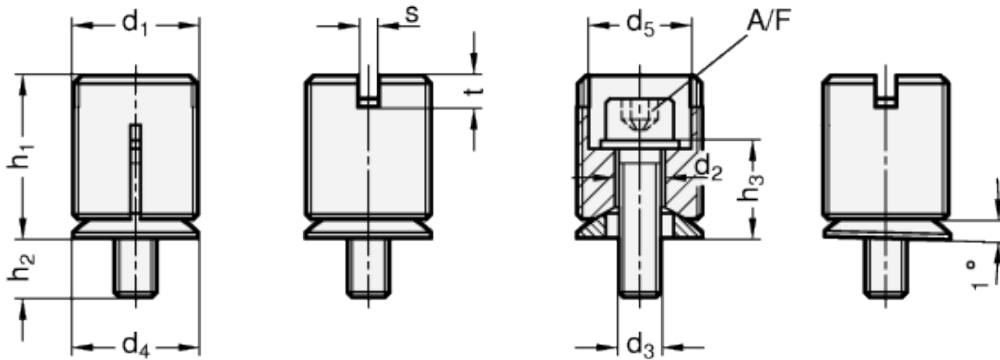

Application example

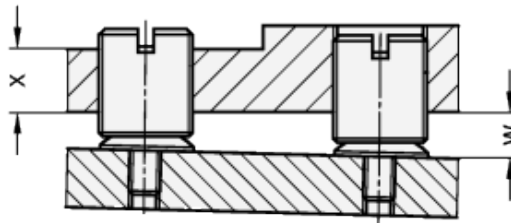

technical informations

Material

Blackened steel.

Cylinder head screw DIN 912, 8.8

Zinc plated steel, blue passivated.

Washer DIN 433

Zinc plated steel, blue passivated.

Spherical washer

Case-hardened.

Accessories on request

Assembly tool GN 355.1 (Code no. see table)

Features and applications

Levelling elements GN 355 are used for levelling and adjusting in machines and equipment.

They consist of a levelling screw, a cylinder screw with disk and a spherical washer. After making the adjustment using the assembly tools GN 355.1 available as accessory, the screw is tightened firmly causing the levelling screw and the spherical washer DIN 6319 underneath to spread and is so secured against twisting in the taphole.

The values for w and x given in the table and for the static load capacity are to be seen as reference values which may differ depending on the prevailing situation. In general, they do not constitute a warranty of condition. The user must determine whether the product is suitable for the intended purpose.

| Standard Elements | Main dimensions | | | | | | | | | | | | | Static load F in KN | Code no. Assembly tool | Weight |
|----------------------|-----------------|----------------|----------------|----------------|----------------|----------------|----------------|----------------|----------------|----|-----|----|-------------------|---------------------|------------------------|-------------------|
| | Description | d ₁ | d ₂ | d ₃ | d ₄ | d ₅ | h ₁ | h ₂ | h ₃ | s | A/F | t | w _{max.} | | | x _{min.} |
| GN 355-M12x1-4.5-ST | M12x1 | 4.5 | M4 | 12 | 9.1 | 19.1 | 10.9 | 9.1 | 2 | 3 | 3 | 8 | 8 | 4.4 | GN 355.1-12 | 11 |
| GN 355-M18x1-7-ST | M18x1 | 7 | M6 | 17 | 12.6 | 26.8 | 10.1 | 14.9 | 2 | 5 | 3 | 13 | 12 | 10 | GN 355.1-18 | 36 |
| GN 355-M24x1.5-9-ST | M 24x1.5 | 9 | M8 | 24 | 19.6 | 31.1 | 11.3 | 18.7 | 4 | 8 | 6 | 17 | 16 | 29.5 | GN 355.1-24 | 63 |
| GN 355-M30x1.5-13-ST | M30x1.5 | 13 | M12 | 30 | 25.6 | 32.6 | 20.4 | 19.6 | 4 | 10 | 6 | 17 | 20 | 43 | GN 355.1-30 | 124 |
| GN 355-M36x1.5-18-ST | M36x1.5 | 18 | M16 | 36 | 31.6 | 45.7 | 15.8 | 24.2 | 4 | 14 | 6 | 21 | 24 | 91 | GN 355.1-36 | 228 |



STANDARD MACHINE ELEMENTS WORLDWIDE