

GN 350

Levelling sets

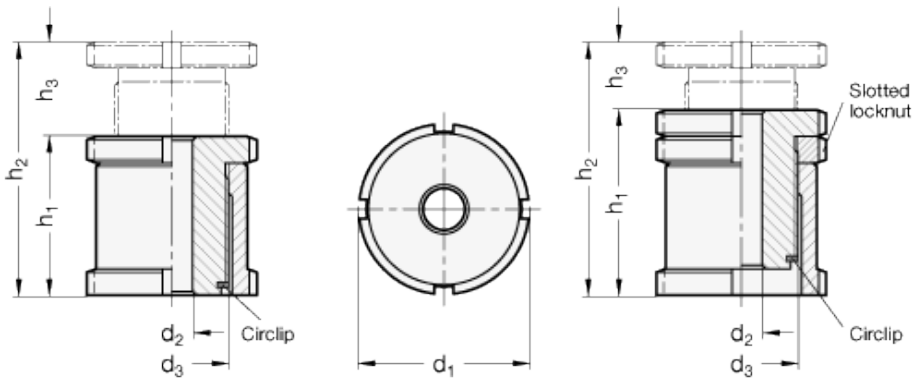

technical informations

Material

Zinc-plated steel ST.

F_1 : max. total load.

F_2 : max. load after deduction of the max. preload for screws 8.8, $\mu = 0,125$.

Standard versions available

- Version A: without locknut.
- Version AK: with locknut.

Features and applications

Levelling sets GN 350 are used for levelling and linking operations. They comprise a threaded upper sleeve and a female threaded lower sleeve. The fine thread allows a stepless and precise setting and locking using the C-Spanner DIN 1810. A locking ring serves also as a height limiter for the max. height.

Normally this screw is permanently and securely locked by the static load created when the mounting screw is tightened. Should this not be sufficient, the use of a locknut (Version AK) is recommended.

Accessories on request

C-Spanner DIN 1810 (code no. see table).

Standard Elements	Main dimensions						for screw	Static load		C-Spanner DIN 1810	Weigh g
	Description	d ₁	d ₂	d ₃	h ₁	h ₂		h ₃	F ₁		
GN 350-25-5.5-A-ST	25	5.5	M15x1	28	43	15	M5	40	33.4	DIN 1810-A25-28	71
GN 350-25-6.6-A-ST	25	6.6	M15x1	28	43	15	M6	40	30.7	DIN 1810-A25-28	68
GN 350-32-6.6-A-ST	32	6.6	M20x1	35	55	20	M6	65	55.7	DIN 1810-A30-32	161
GN 350-32-9-A-ST	32	9	M20x1	35	55	20	M8	65	48	DIN 1810-A30-32	152
GN 350-32-11-A-ST	32	11	M20x1	35	55	20	M10	65	37.9	DIN 1810-A30-32	144
GN 350-45-11-A-ST	45	11	M30x1	42	67	25	M10	120	92.9	DIN 1810-A45-50	372
GN 350-45-13.5-A-ST	45	13.5	M30x1	42	67	25	M12	120	80.4	DIN 1810-A45-50	349
GN 350-45-17.5-A-ST	45	17.5	M30x1	42	67	25	M16	120	45.5	DIN 1810-A45-50	318
GN 350-58-17.5-A-ST	58	17.5	M40x1	54	86	32	M16	210	136	DIN 1810-A58-62	782
GN 350-58-22-A-ST	58	22	M40x1.5	54	86	32	M20	210	90	DIN 1810-A58-62	730
GN 350-58-26-A-ST	58	26	M40x1.5	54	86	32	M24	210	37	DIN 1810-A58-62	666
GN 350-70-22-A-ST	70	22	M50x1.5	66	106	40	M20	330	210	DIN 1810-A68-75	1440
GN 350-70-26-A-ST	70	26	M50x1.5	66	106	40	M24	330	157	DIN 1810-A68-75	1360
GN 350-70-33-A-ST	70	33	M50x1.5	66	106	40	M30	330	53	DIN 1810-A68-75	1200
GN 350-80-26-A-ST	80	26	M60x2	76	126	50	M24	495	322	DIN 1810-A80-90	2167
GN 350-80-33-A-ST	80	33	M60x2	76	126	50	M30	495	218	DIN 1810-A80-90	1862
GN 350-80-39-A-ST	80	39	M60x2	76	126	50	M36	495	101	DIN 1810-A80-90	1671
GN 350-25-5.5-AK-ST	25	5.5	M15x1	28	43	15	M5	40	33.4	DIN 1810-A25-28	80
GN 350-25-6.6-AK-ST	25	6.6	M15x1	33	43	10	M6	40	30.7	DIN 1810-A25-28	78
GN 350-32-6.6-AK-ST	32	6.6	M20x1	41	55	14	M6	65	55.7	DIN 1810-A30-32	179
GN 350-32-9-AK-ST	32	9	M20x1	41	55	14	M8	65	48	DIN 1810-A30-32	172
GN 350-32-11-AK-ST	32	11	M20x1	41	55	14	M10	65	37.9	DIN 1810-A30-32	166
GN 350-45-11-AK-ST	45	11	M30x1.5	49	67	18	M10	120	92.9	DIN 1810-A45-50	409
GN 350-45-13.5-AK-ST	45	13.5	M30x1	49	67	18	M12	120	80.4	DIN 1810-A45-50	393
GN 350-45-17.5-AK-ST	45	17.5	M30x1	49	67	18	M16	120	45.5	DIN 1810-A45-50	365
GN 350-58-17.5-AK-ST	58	17.5	M40x1.5	63	86	23	M16	210	136	DIN 1810-A58-62	882
GN 350-58-22-AK-ST	58	22	M40x1.5	63	86	23	M20	210	90	DIN 1810-A58-62	823
GN 350-58-26-AK-ST	58	26	M40x1.5	63	86	23	M24	210	37	DIN 1810-A58-62	762
GN 350-70-22-AK-ST	70	22	M50x1.5	77	106	29	M20	330	210	DIN 1810-A68-75	1595
GN 350-70-26-AK-ST	70	26	M50x1.5	77	106	29	M24	330	157	DIN 1810-A68-75	1516
GN 350-70-33-AK-ST	70	33	M50x1.5	77	106	29	M30	330	53	DIN 1810-A68-75	1344
GN 350-80-26-AK-ST	80	26	M60x2	87	126	39	M24	495	322	DIN 1810-A80-90	2340
GN 350-80-33-AK-ST	80	33	M60x2	87	126	39	M30	495	218	DIN 1810-A80-90	2140
GN 350-80-39-AK-ST	80	39	M60x2	87	126	39	M36	495	101	DIN 1810-A80-90	1840



STANDARD MACHINE ELEMENTS WORLDWIDE