

GN 350-NI

Levelling sets

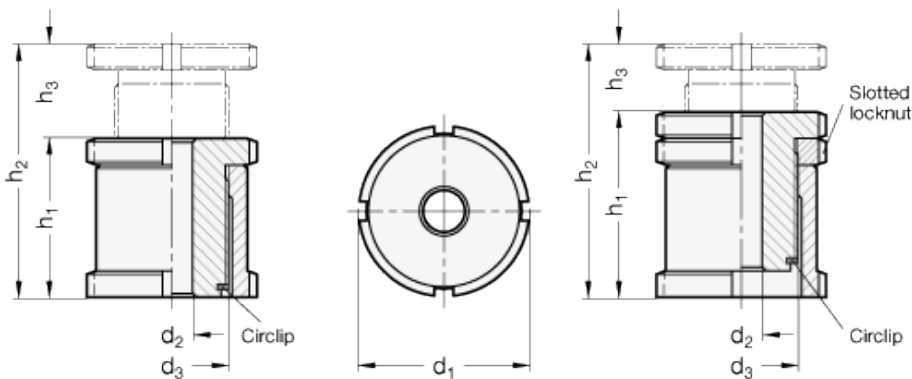

INOX
Stainless Steel



technical informations

Material

AISI 303 stainless steel NI.

F_1 : max. total load.

F_2 : max. load after deduction of the max. preload for screws 6.8, $\mu = 0,14$.

Standard versions available

- Version A: without locknut.
- Version AK: with locknut.

Features and applications

Levelling sets GN 350 are used for levelling and linking operations. They comprise a threaded upper sleeve and a female threaded lower sleeve. The fine thread allows a stepless and precise setting and locking using the C-Spanner DIN 1810. A locking ring serves also as a height limiter for the max. height.

Normally this screw is permanently and securely locked by the static load created when the mounting screw is tightened. Should this not be sufficient, the use of a locknut (Version AK) is recommended.

Accessories on request

C-Spanner DIN 1810 (code no. see table).

Standard Elements	Main dimensions						for screw	Static load F in kN		C-Spanner	Weight g
	d ₁	d ₂	d ₃	h ₁	h ₂	h ₃		F ₁	F ₂		
GN 350-25-5.5-A-NI	25	5.5	M15x1	28	43	15	M5	27.1	20.2	DIN 1810-A25-28	71
GN 350-25-6.6-A-NI	25	6.6	M15x1	28	43	15	M6	27.1	20.2	DIN 1810-A25-28	69
GN 350-32-6.6-A-NI	32	6.6	M20x1	35	55	20	M6	43.4	36.5	DIN 1810-A30-32	163
GN 350-32-9-A-NI	32	9	M20x1	35	55	20	M8	43.4	30.8	DIN 1810-A30-32	154
GN 350-32-11-A-NI	32	11	M20x1	35	55	20	M10	43.4	23.4	DIN 1810-A30-32	145
GN 350-45-11-A-NI	45	11	M30x1.5	42	67	25	M10	84	64	DIN 1810-A45-50	338
GN 350-45-13.5-A-NI	45	13.5	M30x1.5	42	67	25	M12	84	54.8	DIN 1810-A45-50	335
GN 350-45-17.5-A-NI	45	17.5	M30x1.5	42	67	25	M16	84	28.9	DIN 1810-A45-50	320
GN 350-58-17.5-A-NI	58	17.5	M40x1.5	54	86	32	M16	148	92.9	DIN 1810-A58-62	791
GN 350-58-22-A-NI	58	22	M40x1.5	54	86	32	M20	148	59	DIN 1810-A58-62	733
GN 350-58-26-A-NI	58	26	M40x1.5	54	86	32	M24	148	20.3	DIN 1810-A58-62	668
GN 350-70-22-A-NI	70	22	M50x1.5	66	106	40	M20	225	136	DIN 1810-A68-75	1452
GN 350-70-26-A-NI	70	26	M50x1.5	66	106	40	M24	225	97.3	DIN 1810-A68-75	1370
GN 350-70-33-A-NI	70	33	M50x1.5	66	106	40	M30	225	20.6	DIN 1810-A68-75	1210
GN 350-80-26-A-NI	80	26	M60x2	76	126	50	M24	323	195.3	DIN 1810-A80-90	2180
GN 350-80-33-A-NI	80	33	M60x2	76	126	50	M30	323	118.6	DIN 1810-A80-90	1875
GN 350-80-39-A-NI	80	39	M60x2	76	126	50	M36	323	38.2	DIN 1810-A80-90	1683
GN 350-25-5.5-AK-NI	25	5.5	M15x1	33	43	10	M5	27.1	20.2	DIN 1810-A25-28	80
GN 350-25-6.6-AK-NI	25	6.6	M15x1	33	43	10	M6	27.1	20.2	DIN 1810-A25-28	79
GN 350-32-6.6-AK-NI	32	6.6	M20x1	41	55	14	M6	43.4	36.5	DIN 1810-A30-32	181
GN 350-32-9-AK-NI	32	9	M20x1	41	55	14	M8	43.4	30.8	DIN 1810-A30-32	174
GN 350-32-11-AK-NI	32	11	M20x1	41	55	14	M10	43.4	23.4	DIN 1810-A30-32	167
GN 350-45-11-AK-NI	45	11	M30x1.5	49	67	18	M10	84	64	DIN 1810-A45-50	411
GN 350-45-13.5-AK-NI	45	13.5	M30x1.5	49	67	18	M12	84	54.8	DIN 1810-A45-50	405
GN 350-45-17.5-AK-NI	45	17.5	M30x1.5	49	67	18	M16	84	28.9	DIN 1810-A45-50	377
GN 350-58-17.5-AK-NI	58	17.5	M40x1.5	63	86	23	M16	148	92.9	DIN 1810-A58-62	893
GN 350-58-22-AK-NI	58	22	M40x1.5	63	86	23	M20	148	59	DIN 1810-A58-62	834
GN 350-58-26-AK-NI	58	26	M40x1.5	63	86	23	M24	148	20.3	DIN 1810-A58-62	775
GN 350-70-22-AK-NI	70	22	M50x1.5	77	106	29	M20	225	136	DIN 1810-A68-75	1607
GN 350-70-26-AK-NI	70	26	M50x1.5	77	106	29	M24	225	97.3	DIN 1810-A68-75	1426
GN 350-70-33-AK-NI	70	33	M50x1.5	77	106	29	M30	225	20.6	DIN 1810-A68-75	1354
GN 350-80-26-AK-NI	80	26	M60x2	87	126	39	M24	323	195.3	DIN 1810-A80-90	2356
GN 350-80-33-AK-NI	80	33	M60x2	87	126	39	M30	323	118.6	DIN 1810-A80-90	2155
GN 350-80-39-AK-NI	80	39	M60x2	87	126	39	M36	323	38.2	DIN 1810-A80-90	1852



STANDARD MACHINE ELEMENTS WORLDWIDE