

GN 342.2

Levelling elements

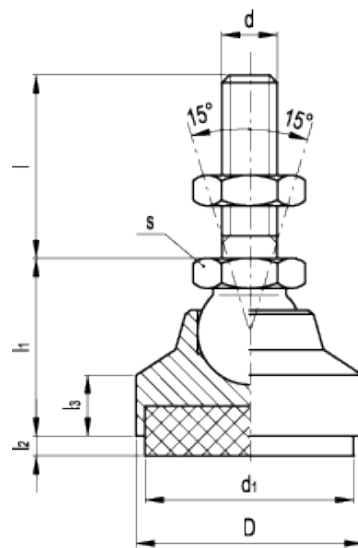

technical informations

Base

Zinc-plated steel.

Damping element

PUR-elastomer (Sylomer V12), grey colour, glued into the base housing, resistant to oil and to temperatures from -30°C to $+70^{\circ}\text{C}$.

Hexagon nut

Zinc-plated steel.

Stem

Zinc-plated steel, threaded.

Technical data

The load values in the table below represent the limit which the damping insert can withstand permanently.

The static load equals a thrust on the area by 0.4 N/mm^2 , at which the damping material reaches its optimum dynamic damping ability. This also takes into consideration an additional load of 0.6 N/mm^2 in case of a dynamic load.

When using GN 342.2 threaded stem levelling elements the following differentiation in vibration absorption is made:

- active vibrations: vibrations transmitted to surroundings or associated equipment from working machinery for example.
- passive vibrations: vibrations transmitted to equipment or parts from vibrating surroundings or bases.

The efficiency of vibration absorption depends on the interference frequency of the vibration to be absorbed as well as on the resonant frequency of the damping element itself.

A vibration absorbing effect is only achieved when the interference frequency is greater than $\sqrt{2}$ times the resonant frequency of the damping element. The greater the difference (Δ) between the two, the better is the damping effect. The resonant frequency of the damping pad depends on the type (composition) of the material cross section and the static load.

The Vibration absorption - Performance graphs show all required data of standard material (SV12) of the damping pad.

Damping materials with other absorption properties are available on request.

Order information

The levelling element is supplied assembled.

Example

Assume a load per levelling foot: 400 N.

Compression levelling foot D = 32

400 N

$707 \text{ mm}^2 = 0,57 \text{ N/mm}^2$

Compression levelling foot D = 40

400 N

$1134 \text{ mm}^2 = 0,34 \text{ N/mm}^2$

Therefore levelling feet with D=40, that exert a pressure of 0.4 N/mm^2 should be preferred.

The above graph shows:

Resonant frequency with compression 0.34 N/mm^2 : 19 Hz.

The lower graph shows:

Degree of isolation at 66 Hz interference frequency (P1): 90%

Degree of isolation at 98 Hz interference frequency (P2): 97%

At approximately 200 Hz interference frequency the degree of isolation is 100%.

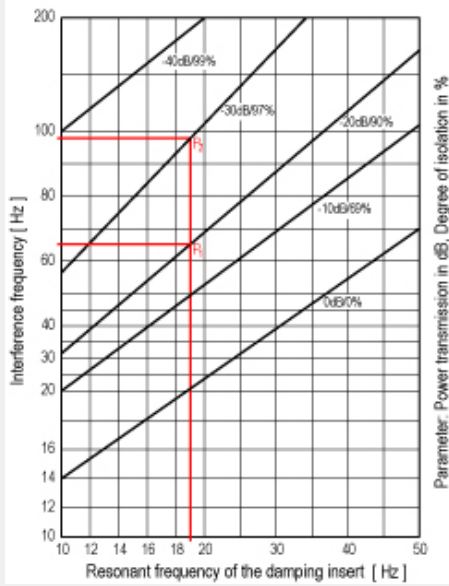
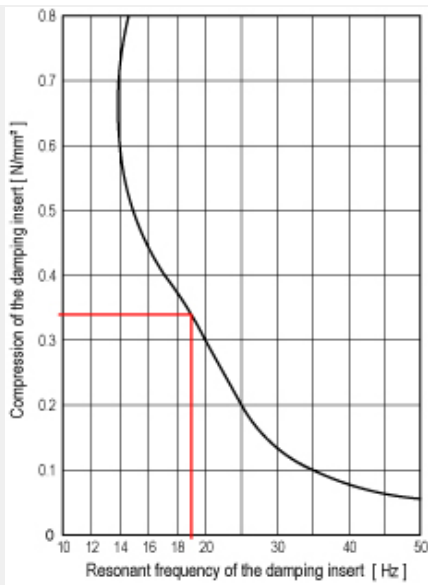

Standard Elements	Main dimensions				Threaded stem		Wrench	I2 compression [N/mm ²]			Area [mm ²] damping insert	Static load # [N]	Weight [g]
	D	d ₁	l ₁	l ₃	d	l		s	0	0.4			
GN 342.2-32-M10-50-SV	32	30	29	11	M10	50	16	5.5	4.3	3.4	707	280	107
GN 342.2-32-M10-80-SV	32	30	29	11	M10	80	16	5.5	4.3	3.4	707	280	122
GN 342.2-40-M12-63-SV	40	38	30	9.5	M12	63	18	6	4.8	3.9	1134	450	160
GN 342.2-40-M12-100-SV	40	38	30	9.5	M12	100	18	6	4.8	3.9	1134	450	189
GN 342.2-50-M12-63-SV	50	48	30.5	9	M12	63	18	6.5	5.3	4.4	1809	720	208
GN 342.2-50-M12-100-SV	50	48	30.5	9	M12	100	18	6.5	5.3	4.4	1809	720	250
GN 342.2-60-M16-80-SV	60	58	37.5	10	M16	80	24	7	5.8	4.9	2641	1050	400
GN 342.2-60-M16-125-SV	60	58	37.5	10	M16	125	24	7	5.8	4.9	2641	1050	495

#See technical data



STANDARD MACHINE ELEMENTS WORLDWIDE