

GN 337

Hinges

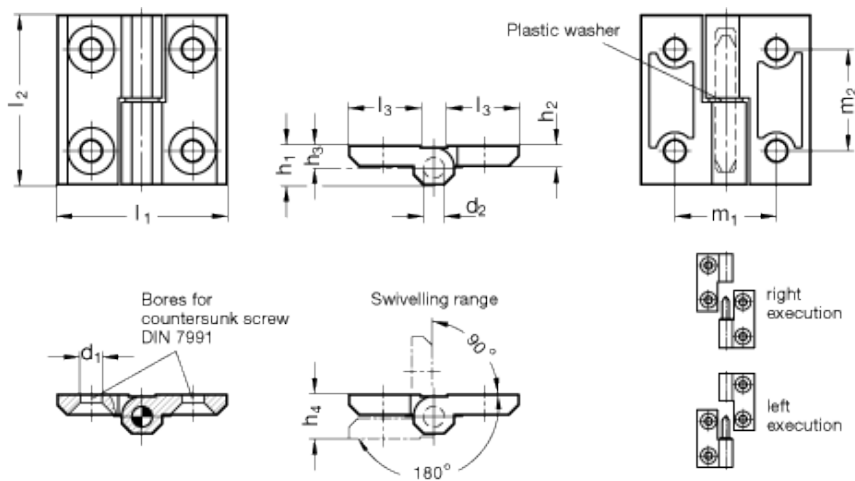

technical informations

Material

- Zinc-alloy die-cast ZD, black matte epoxy resin coating.
- Version SW: RAL 9005, black, matte finish.
- Version SR: RAL 9006, silver, matte finish.

Rotation pin

AISI 303 stainless steel.

- Identification no. 1: fixed bearing (pin) right.
- Identification no. 2: fixed bearing (pin) left.

Assembly

Version A: two couples of through holes for countersunk-head screws.

Rotation angle

Max. 270°, between 0° and -90° and between 0° and 180°.

Standard Elements	Main dimensions												Weight
Description	l_1	l_2	d_1	d_2	h_1	h_2	h_3	$h_{4+0.5}$	l_3	m_1	m_2	g	
GN 337-ZD-40-40-A-1-SW	40	40	5.3	4	9	5	5.5	11	16	25	25	40	
GN 337-ZD-40-40-A-1-SR	40	40	5.3	4	9	5	5.5	11	16	25	25	40	
GN 337-ZD-40-40-A-2-SW	40	40	5.3	4	9	5	5.5	11	16	25	25	41	
GN 337-ZD-40-40-A-2-SR	40	40	5.3	4	9	5	5.5	11	16	25	25	41	
GN 337-ZD-50-50-A-1-SW	50	50	6.4	6	11.5	6	6.5	13	21	30	30	80	
GN 337-ZD-50-50-A-1-SR	50	50	6.4	6	11.5	6	6.5	13	21	30	30	80	
GN 337-ZD-50-50-A-2-SW	50	50	6.4	6	11.5	6	6.5	13	21	30	30	83	
GN 337-ZD-50-50-A-2-SR	50	50	6.4	6	11.5	6	6.5	13	21	30	30	83	
GN 337-ZD-60-60-A-1-SW	60	60	8.3	8	15	8	8.5	17	26	36	36	153	
GN 337-ZD-60-60-A-1-SR	60	60	8.3	8	15	8	8.5	17	26	36	36	153	
GN 337-ZD-60-60-A-2-SW	60	60	8.3	8	15	8	8.5	17	26	36	36	156	
GN 337-ZD-60-60-A-2-SR	60	60	8.3	8	15	8	8.5	17	26	36	36	156	

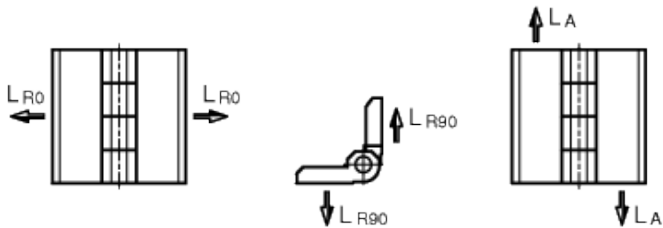

Standard Elements	Radial load in N		Axial load in N
	L_{R0}	L_{R90}	L_A
GN 337-ZD-40-40-A	2200	1600	1500
GN 337-ZD-50-50-A	3000	2500	2500
GN 337-ZD-60-60-A	4300	3500	3100



STANDARD MACHINE ELEMENTS WORLDWIDE