

# GN 321.6-D

Safety solid handwheels with revolving handle

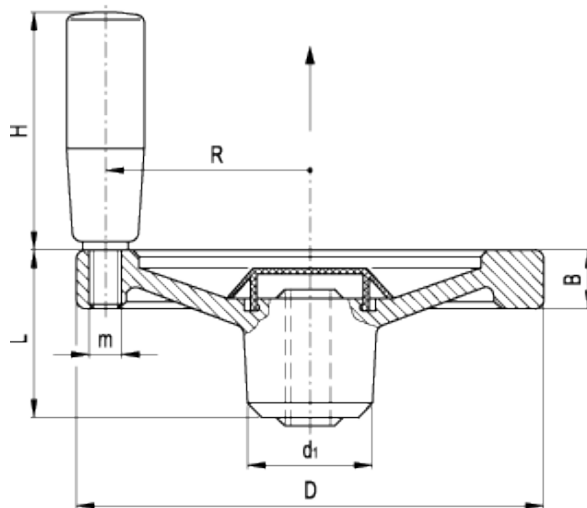

## technical informations

### Material

Aluminium, black epoxy resin coating.

### Rim

Aluminium, mirror-polished.

### Hub cap

Light grey acetal resin based (POM) technopolymer.

### Revolving handle

Type [GN 598](#) steel black epoxy resin coating, matte finish.

### Assembly

Hub with keyway in compliance with [DIN 6885/2 P9 tolerance](#).

*Technical data*

Axial and radial runout lower than 0.4.

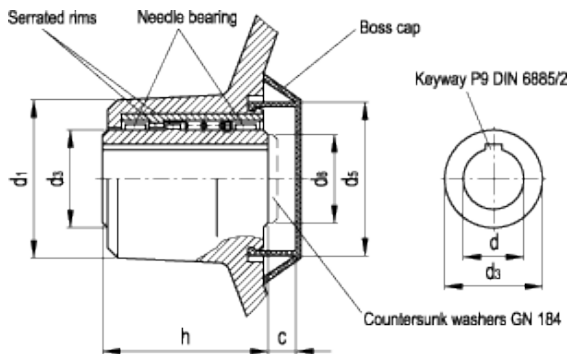

Standard Elements	Main dimensions									Mounting hole	Handle				Weight
Description	D	L	B	d <sub>1</sub>	d <sub>3</sub>	d <sub>5</sub>	d <sub>6 max.</sub>	h	c	d <sub>H7</sub>	H	Ø	m	R	g
GN 321.6-140-K12-D	140	58	16.5	42	24	40	23	45	7	12	67.5	23	M8	61	720
GN 321.6-140-K14-D	140	58	16.5	42	24	40	23	45	7	14	67.5	23	M8	61	705
GN 321.6-140-K16-D	140	58	16.5	42	24	40	23	45	7	16	67.5	23	M8	61	689
GN 321.6-160-K12-D	160	58	18	42	24	40	23	45	7	12	82.5	26	M10	71	952
GN 321.6-160-K14-D	160	58	18	42	24	40	23	45	7	14	82.5	26	M10	71	937
GN 321.6-160-K16-D	160	58	18	42	24	40	23	45	7	16	82.5	26	M10	71	921



STANDARD MACHINE ELEMENTS WORLDWIDE