

## Stainless Steel- Ratchet spanners

### SPECIFICATION

#### Types

- Type **A**: Ratchet insert with through hole
- Type **B**: Ratchet insert with blind hole
- Type **C**: Ratchet insert with threaded stud

#### Housing

Stainless Steel-Sheet AISI 304

#### Ratchet inserts

- Type A: Stainless Steel AISI 316 LHC sintered
- Type B and Type C: Stainless Steel AISI 303 turned

#### Locking pawl

Stainless Steel AISI 316 LHC sintered

#### Grip element

Plastic, Technopolymer (Polyamide)

#### Other components

Stainless Steel

### INFORMATION

GN 318 Stainless Steel-Ratchet spanners are robust, easy to handle and ergonomically shaped to sit easily in the hand.

Stainless Steel-Ratchet spanners are normally used wherever the same ratchet insert is always required or where it makes sense to leave the ratchet spanner at the place of use or attach it to equipment or machinery as a „stationary“ tool. The ratchet inserts are available in different versions depending on their type and are permanently fixed in the housing. Due to the high-quality materials, the ratchet spanner is suitable for use in aggressive environments.

### TECHNICAL INFORMATION

- Square DIN 79 (see page A16)
- Keyway P9 DIN 6885 (see page A16)
- ISO-Fundamental Tolerances (see page A21)
- Plastic characteristics (see page A2)
- Stainless Steel characteristics (see page A26)

### ON REQUEST

- Other inserts (Type A / B)
- Other inserts (Type C) analog GN 300.1-92 (see page 325) (code no. see table)

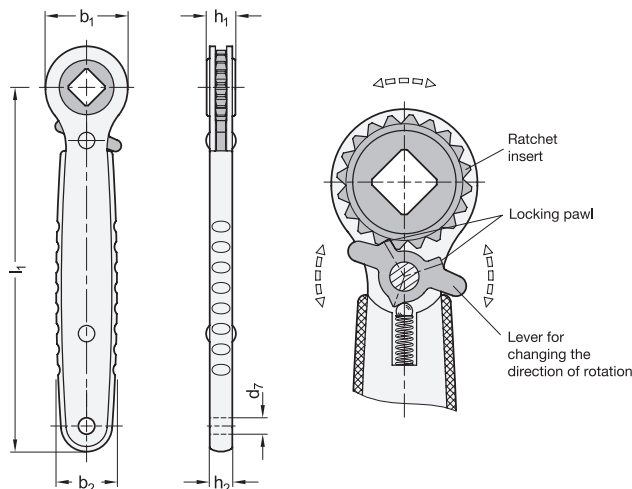

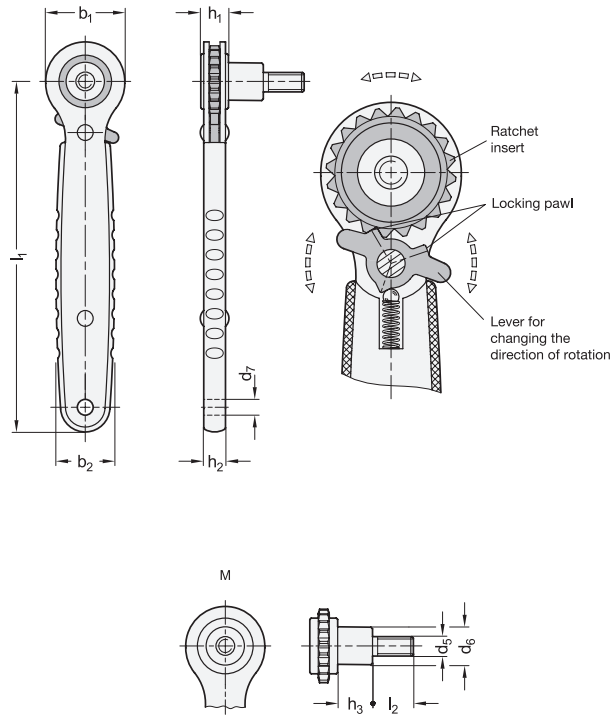

GN 318

STAINLESS STEEL

Description	l1	d1	d2 H7	d3	d4	s1	s2	b1	b2	d6	d7	h1	h2	h3	t min.	⚖
GN 318-178-M10-A	178	M 10	-	-	-	-	-	40	29.6	-	8	14	10.9	-	-	257
GN 318-178-M12-A	178	M 12	-	-	-	-	-	40	29.6	-	8	14	10.9	-	-	254
GN 318-178-M16-A	178	M 16	-	-	-	-	-	40	29.6	-	8	14	10.9	-	-	247
GN 318-178-K10-A	178	-	K 10	-	-	-	-	40	29.6	-	8	14	10.9	-	-	254
GN 318-178-K12-A	178	-	K 12	-	-	-	-	40	29.6	-	8	14	10.9	-	-	250
GN 318-178-K16-A	178	-	K 16	-	-	-	-	40	29.6	-	8	14	10.9	-	-	241
GN 318-178-V10-A	178	-	-	-	-	V 10	-	40	29.6	-	8	14	10.9	-	-	252
GN 318-178-V14-A	178	-	-	-	-	V 14	-	40	29.6	-	8	14	10.9	-	-	243
GN 318-178-V17-A	178	-	-	-	-	V 17	-	40	29.6	-	8	14	10.9	-	-	233
GN 318-178-SK10-A	178	-	-	-	-	-	SK 10	40	29.6	-	8	14	10.9	-	-	254
GN 318-178-SK14-A	178	-	-	-	-	-	SK 14	40	29.6	-	8	14	10.9	-	-	245
GN 318-178-SK17-A	178	-	-	-	-	-	SK 17	40	29.6	-	8	14	10.9	-	-	237
GN 318-178-M8-B	178	-	-	M 8	-	-	-	40	29.6	19	8	14	10.9	17.5	17	296
GN 318-178-M10-B	178	-	-	M 10	-	-	-	40	29.6	19	8	14	10.9	17.5	17	292
GN 318-178-M12-B	178	-	-	M 12	-	-	-	40	29.6	19	8	14	10.9	17.5	17	288
GN 318-178-B8-B	178	-	-	-	B 8	-	-	40	29.6	19	8	14	10.9	17.5	17	293
GN 318-178-B10-B	178	-	-	-	B 10	-	-	40	29.6	19	8	14	10.9	17.5	17	289
GN 318-178-B12-B	178	-	-	-	B 12	-	-	40	29.6	19	8	14	10.9	17.5	17	283

GN-318

STAINLESS STEEL

Description	l1	d5	l2	b1	b2	d6	d7	h1	h2	h3	⚖
GN 318-178-M8-16-C	178	M 8	16	40	29.6	19	8	14	10.9	17.5	308
GN 318-178-M8-32-C	178	M 8	32	40	29.6	19	8	14	10.9	17.5	314
GN 318-178-M10-20-C	178	M 10	20	40	29.6	19	8	14	10.9	17.5	314
GN 318-178-M10-40-C	178	M 10	40	40	29.6	19	8	14	10.9	17.5	327
GN 318-178-M12-25-C	178	M 12	25	40	29.6	19	8	14	10.9	17.5	324
GN 318-178-M12-50-C	178	M 12	50	40	29.6	19	8	14	10.9	17.5	346



Clamping levers