

Stainless Steel-Locking pins

with L-Handle, lockable

SPECIFICATION

Type

- Type L: with L-handle

Identification

- **SC**: Operation with key (same lock)
- **SU**: Operation with key (different lock)

Plunger pin / Pawl
Stainless Steel AISI 303 **NI**

L-Handle
Plastic (Polyamide PA)

- black
- temperature resistant up to 80 °C

Lock mechanism
Zinc die casting / Stainless Steel

Key (two pieces)
Steel, nickel plated



INFORMATION

Stainless Steel-Locking pins GN 314 with L-Handle and key are used for quick fixing, connecting and locking of various jig and fixture systems without the need for tools. Turning the key 180° moves the pawl at the front end of the pin to engage the axial locking of the inserted pin. After locking, unauthorized removal is no longer possible. The key can be removed in both end positions.

- Range of lock pins (see page 868)

ACCESSORY

- Ball chains GN 111 (see page 904)
- Stainless Steel-Ball chains GN 111.5 (see page 905)
- Retaining cables GN 111.2 (see page 906)
- Spiral retaining cables GN 111.4 (see page 908)

TECHNICAL INFORMATION

- ISO-Fundamental Tolerances (see page A21)
- Stainless Steel characteristics (see page A26)

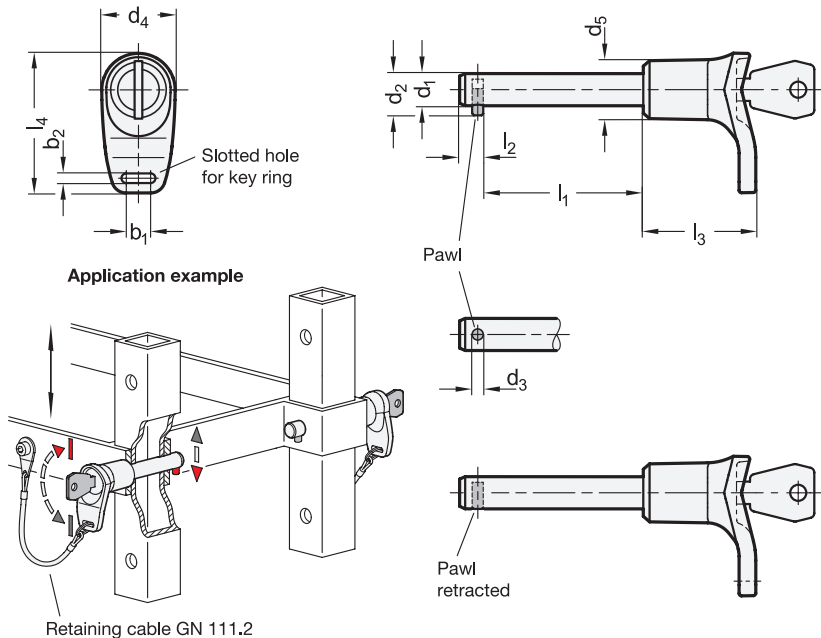



Indexing elements

* Complete with Identification of the Stainless Steel-Locking pins (SC or SU)

SC Operation with key (same lock) **SU** Operation with key (different lock)

GN 314

STAINLESS STEEL

Description	d1 -0.05	l1 +0.5	b1	b2	d2	d3	d4	d5	l2 ±1	l3	l4	Load in kN ≈ (Double sided shear force) see information	
GN 314-8-20-L-*-NI	8	20	7.5	3	9.5	3	23	18	4.5	35	43.5	30	47
GN 314-8-25-L-*-NI	8	25	7.5	3	9.5	3	23	18	4.5	35	43.5	30	49
GN 314-8-30-L-*-NI	8	30	7.5	3	9.5	3	23	18	4.5	35	43.5	30	51
GN 314-8-35-L-*-NI	8	35	7.5	3	9.5	3	23	18	4.5	35	43.5	30	53
GN 314-8-40-L-*-NI	8	40	7.5	3	9.5	3	23	18	4.5	35	43.5	30	55
GN 314-8-50-L-*-NI	8	50	7.5	3	9.5	3	23	18	4.5	35	43.5	30	62
GN 314-10-20-L-*-NI	10	20	7.5	3	12.6	3	23	18	4.5	35	43.5	46	37
GN 314-10-25-L-*-NI	10	25	7.5	3	12.6	3	23	18	4.5	35	43.5	46	37
GN 314-10-30-L-*-NI	10	30	7.5	3	12.6	3	23	18	4.5	35	43.5	46	59
GN 314-10-35-L-*-NI	10	35	7.5	3	12.6	3	23	18	4.5	35	43.5	46	62
GN 314-10-40-L-*-NI	10	40	7.5	3	12.6	3	23	18	4.5	35	43.5	46	65
GN 314-10-50-L-*-NI	10	50	7.5	3	12.6	3	23	18	4.5	35	43.5	46	71
GN 314-10-60-L-*-NI	10	60	7.5	3	12.6	3	23	18	4.5	35	43.5	46	77
GN 314-12-30-L-*-NI	12	30	7.5	3	14.6	4	23	18	6	35	43.5	74	69
GN 314-12-35-L-*-NI	12	35	7.5	3	14.6	4	23	18	6	35	43.5	74	73
GN 314-12-40-L-*-NI	12	40	7.5	3	14.6	4	23	18	6	35	43.5	74	77
GN 314-12-50-L-*-NI	12	50	7.5	3	14.6	4	23	18	6	35	43.5	74	86
GN 314-12-60-L-*-NI	12	60	7.5	3	14.6	4	23	18	6	35	43.5	74	95
GN 314-12-70-L-*-NI	12	70	7.5	3	14.6	4	23	18	6	35	43.5	74	104
GN 314-12-80-L-*-NI	12	80	7.5	3	14.6	4	23	18	6	35	43.5	74	112
GN 314-16-30-L-*-NI	16	30	12	4	19.7	5	35.5	28	7.5	40.5	65	136	141
GN 314-16-35-L-*-NI	16	35	12	4	19.7	5	35.5	28	7.5	40.5	65	136	151
GN 314-16-40-L-*-NI	16	40	12	4	19.7	5	35.5	28	7.5	40.5	65	136	156
GN 314-16-50-L-*-NI	16	50	12	4	19.7	5	35.5	28	7.5	40.5	65	136	171
GN 314-16-60-L-*-NI	16	60	12	4	19.7	5	35.5	28	7.5	40.5	65	136	187
GN 314-16-70-L-*-NI	16	70	12	4	19.7	5	35.5	28	7.5	40.5	65	136	204
GN 314-16-80-L-*-NI	16	80	12	4	19.7	5	35.5	28	7.5	40.5	65	136	218
GN 314-20-60-L-*-NI	20	60	12	4	23.7	5	35.5	28	7.5	40.5	65	227	247
GN 314-20-80-L-*-NI	20	80	12	4	23.7	5	35.5	28	7.5	40.5	65	227	295
GN 314-20-100-L-*-NI	20	100	12	4	23.7	5	35.5	28	7.5	40.5	65	227	344
GN 314-20-120-L-*-NI	20	120	12	4	23.7	5	35.5	28	7.5	40.5	65	227	396

Weight Identification SC