

GN 313

Indexing plungers

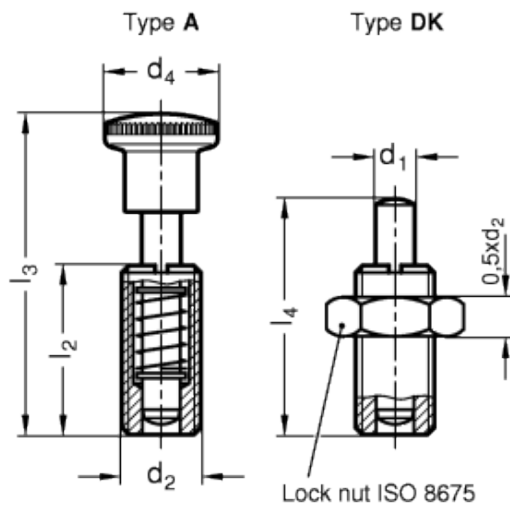

Normal position:
Plunger retracted



Identification 2

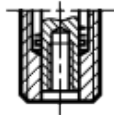

Operating position:
Plunger protruded

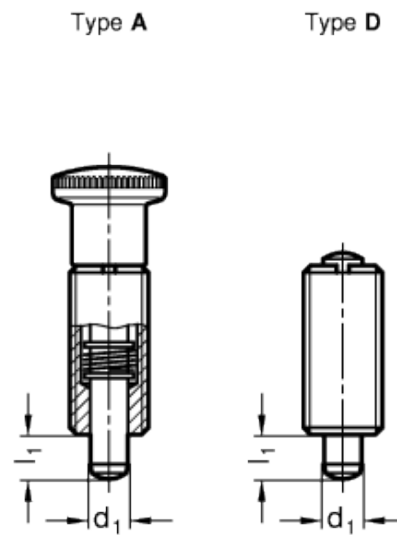

Identification 2

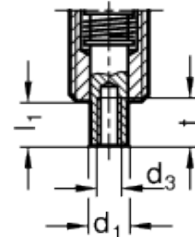

Plunger

AISI 303 stainless steel, chemically nickel-plated. Suggested matching hole in H7 tolerance.

"Push/Pull" knurled knob

High resilience polyamide based (PA) technopolymer, black colour, matte finish. Resistant to solvents, oils, greases and other chemical agents.

Standard versions available

- Type A: with knob, without lock nut.
- Type AK: with knob, with lock nut.
- Type D: without knob, without lock nut.
- Type DK: without knob, with lock nut.

Versions

- Identification no. 1: Plunger without internal thread.
- Identification no. 2: Plunger with internal thread.

Features and applications

The plunger of the spring bolts GN 313 does not protrude in the inoperative position. It can be operated manually or in Type D and DK mechanically (pneumatic cylinder, cam plate, etc.) when it will protrude only as long as it is operated. Using the internal thread at identification 2 on the pressure side, special pressure bolts or a rod arrangement can be operated, for instance.

Standard Elements	Main dimensions									Spring pressure in N \approx		Weight	
	Description	d_1 -0.02/-0.04	d_2	d_3	d_4	$l_1 \approx$	l_2	$l_3 \approx$	$l_4 \approx$	$t_{min.}$	Preload		Max. load
GN 313-5-A-1-ST	5	M10x1	-	16	6	22	42	-	-	-	8	20	-
GN 313-5-A-2-ST	5	M10x1	M3	16	6	22	42	-	7	7	8	20	-
GN 313-6-A-1-ST	6	M12x1.5	-	19	7	26	49	-	-	-	9	28	18
GN 313-6-A-2-ST	6	M12x1.5	M4	19	7	26	49	-	7	7	9	28	20
GN 313-8-A-1-ST	8	M16x1.5	-	23	7	34	65	-	-	-	12	40	47
GN 313-8-A-2-ST	8	M16x1.5	M5	23	9	34	65	-	9	9	12	40	48
GN 313-10-A-1-ST	10	M20x1.5	-	28	11	43	78	-	-	-	22	50	70
GN 313-10-A-2-ST	10	M20x1.5	M6	28	11	43	78	-	12	12	22	50	75
GN 313-5-AK-1-ST	5	M10x1	-	16	6	22	42	-	-	-	8	20	-
GN 313-5-AK-2-ST	5	M10x1	M3	16	6	22	42	-	7	7	8	20	-
GN 313-6-AK-1-ST	6	M12x1.5	-	19	7	26	49	-	-	-	9	28	20
GN 313-6-AK-2-ST	6	M12x1.5	M4	19	7	26	49	-	7	7	9	28	20
GN 313-8-AK-1-ST	8	M16x1.5	-	23	9	34	65	-	-	-	12	40	66
GN 313-8-AK-2-ST	8	M16x1.5	M5	23	9	34	65	-	9	9	12	40	67
GN 313-10-AK-1-ST	10	M20x1.5	-	28	11	43	78	-	-	-	22	50	78
GN 313-10-AK-2-ST	10	M20x1.5	M6	28	11	43	78	-	12	12	22	50	80
GN 313-5-D-1-ST	5	M10x1	-	-	6	22	-	29	-	-	8	20	-
GN 313-5-D-2-ST	5	M10x1	M3	-	6	22	-	29	7	7	8	20	-
GN 313-6-D-1-ST	6	M12x1.5	-	-	7	26	-	35	-	-	9	28	22
GN 313-6-D-2-ST	6	M12x1.5	M4	-	7	26	-	35	7	7	9	28	22
GN 313-8-D-1-ST	8	M16x1.5	-	-	9	34	-	48	-	-	12	40	43
GN 313-8-D-2-ST	8	M16x1.5	M5	-	9	34	-	48	9	9	12	40	42

GN 313-10-D-1-ST	10	M20x1.5	-	-	11	43	-	57	-	22	50	83
GN 313-10-D-2-ST	10	M20x1.5	M6	-	11	43	-	57	12	22	50	83
GN 313-5-DK-1-ST	5	M10x1	-	-	6	22	-	29	-	8	20	-
GN 313-5-DK-2-ST	5	M10x1	M3	-	6	22	-	29	7	8	20	-
GN 313-6-DK-1-ST	6	M12x1.5	-	-	7	26	-	35	-	9	28	25
GN 313-6-DK-2-ST	6	M12x1.5	M4	-	7	26	-	35	7	9	28	30
GN 313-8-DK-1-ST	8	M16x1.5	-	-	9	34	-	48	-	12	40	45
GN 313-8-DK-2-ST	8	M16x1.5	M5	-	9	34	-	48	9	12	40	50
GN 313-10-DK-1-ST	10	M20x1.5	-	-	11	43	-	57	-	22	50	85
GN 313-10-DK-2-ST	10	M20x1.5	M6	-	11	43	-	57	12	22	50	85



STANDARD MACHINE ELEMENTS WORLDWIDE