

Linear actuators

Steel / Stainless Steel, with right or left hand thread

SPECIFICATION

Types

- Type **R1**: Right hand thread, shaft journal at one end
- Type **R2***: Right hand thread, shaft journal at both ends
- Type **L1**: Left hand thread, shaft journal at one end
- Type **L2***: Left hand thread, shaft journal at both ends

* usually not available from stock

Guide tube

Version in Steel

Tube DIN 2391

Steel, chrome-plated **SCR**

Version in Stainless Steel*

Tube DIN 2462

Stainless Steel AISI 304 **NI**

* usually not available from stock

Spindle with trapezoidal thread

- Steel respectively, Stainless Steel AISI 303
- ball bearing

Lead nut

Gunmetal

End cap

Plastic

INFORMATION

In addition to the standard stroke lengths specified in the above table for linear actuators GN 291 any stroke inside the maximum stroke length is available.

Besides the extensive range of tube clamp connectors there are a number of different components for fixing the linear actuators and to build linear actuator connectors.

In order to measure the displacement and positioning of the linear actuator connectors, digital as well as analogue position indicators can be installed and furthermore the guide tube can be provided with a longitudinal scale.



ACCESSORY

- Linear actuator connectors, tube clamp connectors have to be ordered separately.

ON REQUEST

- Tube DIN 2462 in Stainless Steel **NI**

TECHNICAL INFORMATION

- ISO-Fundamental Tolerances (see page A21)
- Stainless Steel characteristics (see page A26)
- Technical description of Linear actuators (see page 1910)

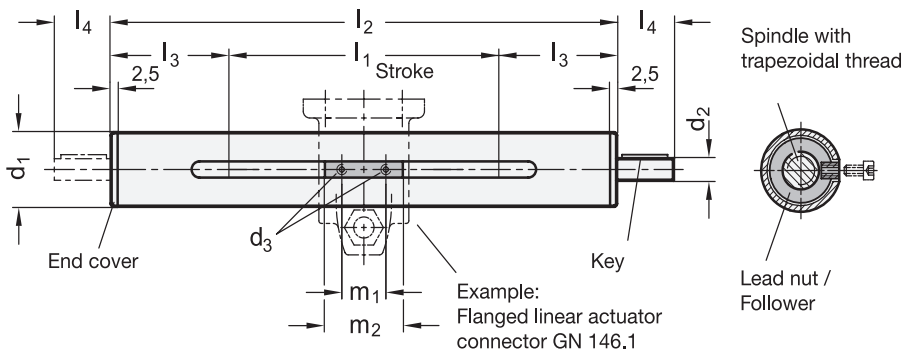

GN 291

Description	d1	l1	Max. stroke	Threaded spindle	d2 f7	d3	l2	l3	l4	m1	m2	For key DIN 6885	⚖
GN 291-18-65-R1-SCR	18	65	350	TR10x3	6	M 3	l1+140	70	16	17	24	A2x2x12	230
GN 291-18-165-R1-SCR	18	165	350	TR10x3	6	M 3	l1+140	70	16	17	24	A2x2x12	330
GN 291-18-265-R1-SCR	18	265	350	TR10x3	6	M 3	l1+140	70	16	17	24	A2x2x12	430
GN 291-30-100-R1-SCR	30	100	1250	TR14x4	8	M 4	l1+205	102.5	16	23	38	A2x2x12	780
GN 291-30-150-R1-SCR	30	150	1250	TR14x4	8	M 4	l1+205	102.5	16	23	38	A2x2x12	890
GN 291-30-200-R1-SCR	30	200	1250	TR14x4	8	M 4	l1+205	102.5	16	23	38	A2x2x12	1000
GN 291-30-300-R1-SCR	30	300	1250	TR14x4	8	M 4	l1+205	102.5	16	23	38	A2x2x12	1210
GN 291-40-70-R1-SCR	40	70	1570	TR20x4	12	M 5	l1+235	117.5	17	42	54	A4x4x12	1640
GN 291-40-170-R1-SCR	40	170	1570	TR20x4	12	M 5	l1+235	117.5	17	42	54	A4x4x12	2080
GN 291-40-220-R1-SCR	40	220	1570	TR20x4	12	M 5	l1+235	117.5	17	42	54	A4x4x12	2310
GN 291-40-270-R1-SCR	40	270	1570	TR20x4	12	M 5	l1+235	117.5	17	42	54	A4x4x12	2530
GN 291-40-320-R1-SCR	40	320	1570	TR20x4	12	M 5	l1+235	117.5	17	42	54	A4x4x12	2750
GN 291-50-65-R1-SCR	50	65	1565	TR20x4	12	M 6	l1+240	120	18	42	54	A4x4x12	2410
GN 291-50-115-R1-SCR	50	115	1565	TR20x4	12	M 6	l1+240	120	18	42	54	A4x4x12	2720
GN 291-50-215-R1-SCR	50	215	1565	TR20x4	12	M 6	l1+240	120	18	42	54	A4x4x12	3000
GN 291-50-265-R1-SCR	50	265	1565	TR20x4	12	M 6	l1+240	120	18	42	54	A4x4x12	3670
GN 291-50-315-R1-SCR	50	315	1565	TR20x4	12	M 6	l1+240	120	18	42	54	A4x4x12	3990
GN 291-60-220-R1-SCR	60	220	1520	TR24x5	14	M 8	l1+285	142.5	19	58	70	A5x5x16	5300
GN 291-60-720-R1-SCR	60	720	1520	TR24x5	14	M 8	l1+285	142.5	19	58	70	A5x5x16	10000
GN 291-18-65-L1-SCR	18	65	350	TR10x3	6	M 3	l1+140	70	16	17	24	A2x2x12	230
GN 291-18-165-L1-SCR	18	165	350	TR10x3	6	M 3	l1+140	70	16	17	24	A2x2x12	330
GN 291-18-265-L1-SCR	18	265	350	TR10x3	6	M 3	l1+140	70	16	17	24	A2x2x12	430
GN 291-30-100-L1-SCR	30	100	1250	TR14x4	8	M 4	l1+205	102.5	16	23	38	A2x2x12	780
GN 291-30-150-L1-SCR	30	150	1250	TR14x4	8	M 4	l1+205	102.5	16	23	38	A2x2x12	890
GN 291-30-200-L1-SCR	30	200	1250	TR14x4	8	M 4	l1+205	102.5	16	23	38	A2x2x12	1000
GN 291-30-300-L1-SCR	30	300	1250	TR14x4	8	M 4	l1+205	102.5	16	23	38	A2x2x12	1210
GN 291-40-70-L1-SCR	40	70	1570	TR20x4	12	M 5	l1+235	117.5	17	42	54	A4x4x12	1640
GN 291-40-170-L1-SCR	40	170	1570	TR20x4	12	M 5	l1+235	117.5	17	42	54	A4x4x12	2080
GN 291-40-220-L1-SCR	40	220	1570	TR20x4	12	M 5	l1+235	117.5	17	42	54	A4x4x12	2310
GN 291-40-270-L1-SCR	40	270	1570	TR20x4	12	M 5	l1+235	117.5	17	42	54	A4x4x12	2530
GN 291-40-320-L1-SCR	40	320	1570	TR20x4	12	M 5	l1+235	117.5	17	42	54	A4x4x12	2750
GN 291-50-65-L1-SCR	50	65	1565	TR20x4	12	M 6	l1+240	120	18	42	54	A4x4x12	3000
GN 291-50-115-L1-SCR	50	115	1565	TR20x4	12	M 6	l1+240	120	18	42	54	A4x4x12	2720
GN 291-50-215-L1-SCR	50	215	1565	TR20x4	12	M 6	l1+240	120	18	42	54	A4x4x12	3360
GN 291-50-265-L1-SCR	50	265	1565	TR20x4	12	M 6	l1+240	120	18	42	54	A4x4x12	3670
GN 291-50-315-L1-SCR	50	315	1565	TR20x4	12	M 6	l1+240	120	18	42	54	A4x4x12	3990
GN 291-60-220-L1-SCR	60	220	1520	TR24x5	14	M 8	l1+285	142.5	19	58	70	A5x5x16	5300
GN 291-60-720-L1-SCR	60	720	1520	TR24x5	14	M 8	l1+285	142.5	19	58	70	A5x5x16	9800

