

GN 285

Swivel clamp connector joints

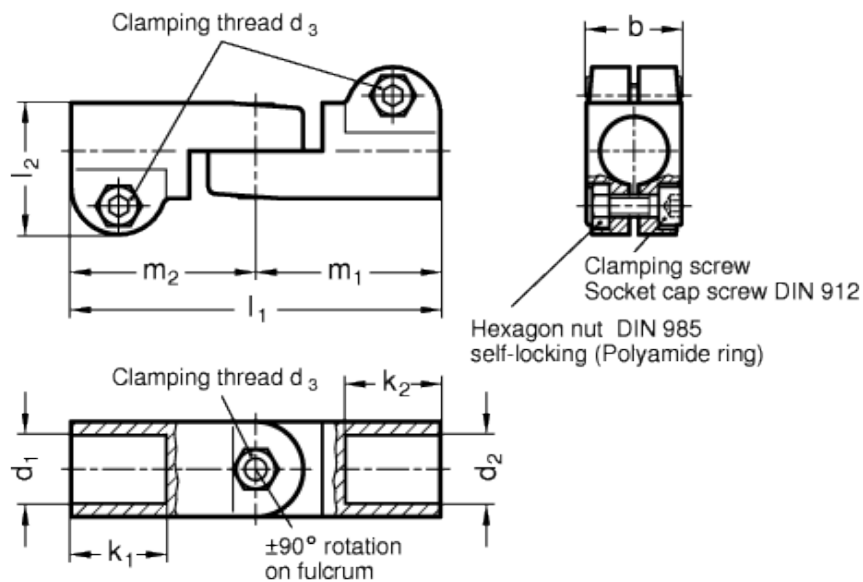

Adjustable clamping lever GN 911

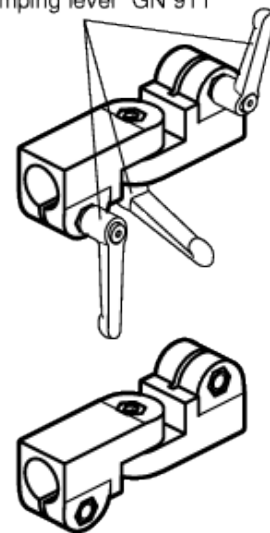

technical informations

Material

Aluminium.

Finish

- Version SW: RAL 9005 black colour, matte finish, epoxy resin coating.
- Version BL: blank, matte shot-blasted.

Clamping screws

Identification no. 2: with three AISI 304 stainless steell-clamping screws DIN 912 and nuts DIN 985.

Assembly

The standard clamping bolts are socket cap screws DIN 912, supplied assembled. They can be replaced by clamping kits GN 911 (description see table of dimensions).

Features and applications

The swivel clamp connector joints GN 285 are an assembly of two swivel clamp connectors GN 275.

Since the swivel clamp connectors have an identical swivel width "b", all bores "d₁ / d₂" can be combined as required.

The clamping bore is machined and designed for construction tubings GN 990 or DIN 2391, DIN 2395 and DIN 2462 respectively.

Accessories

- Tubings [GN 990](#).
- Clamping kits [GN 911](#) (clamping handles GN 300.1 with distance bushing).

Standard Elements	Main dimensions										Clamping kits	Weight
Description	d ₁	d ₂	b	d ₃	k ₁	k ₂	l ₁	l ₂	m ₁	m ₂	For d ₃	g
GN 285-B12-B12-2-*	B12	B12	25	M 6	25	25	97	34.5	48.5	48.5	GN 911-M6-22	156
GN 285-B12-B14-2-*	B12	B14	25	M 6	25	25	97	34.5	48.5	48.5	GN 911-M6-22	146
GN 285-B12-B16-2-*	B12	B16	25	M 6	25	25	97	34.5	48.5	48.5	GN 911-M6-22	146
GN 285-B12-B18-2-*	B12	B18	25	M 6	25	25	97	34.5	48.5	48.5	GN 911-M6-22	146
GN 285-B14-B12-2-*	B14	B12	25	M 6	25	25	97	34.5	48.5	48.5	GN 911-M6-22	146
GN 285-B14-B14-2-*	B14	B14	25	M 6	25	25	97	34.5	48.5	48.5	GN 911-M6-22	148
GN 285-B14-B16-2-*	B14	B16	25	M 6	25	25	97	34.5	48.5	48.5	GN 911-M6-22	146
GN 285-B14-B18-2-*	B14	B18	25	M 6	25	25	97	34.5	48.5	48.5	GN 911-M6-22	146
GN 285-B16-B12-2-*	B16	B12	25	M 6	25	25	97	34.5	48.5	48.5	GN 911-M6-22	146
GN 285-B16-B14-2-*	B16	B14	25	M 6	25	25	97	34.5	48.5	48.5	GN 911-M6-22	146
GN 285-B16-B16-2-*	B16	B16	25	M 6	25	25	97	34.5	48.5	48.5	GN 911-M6-22	144
GN 285-B16-B18-2-*	B16	B18	25	M 6	25	25	97	34.5	48.5	48.5	GN 911-M6-22	146
GN 285-B18-B12-2-*	B18	B12	25	M 6	25	25	97	34.5	48.5	48.5	GN 911-M6-22	146
GN 285-B18-B14-2-*	B18	B14	25	M 6	25	25	97	34.5	48.5	48.5	GN 911-M6-22	146
GN 285-B18-B16-2-*	B18	B16	25	M 6	25	25	97	34.5	48.5	48.5	GN 911-M6-22	146
GN 285-B18-B18-2-*	B18	B18	25	M 6	25	25	97	34.5	48.5	48.5	GN 911-M6-22	136

* Complete the description of the standard item needed by adding the finish of the connector clamps: BL (blank) or SW (black).



STANDARD MACHINE ELEMENTS WORLDWIDE