

GN 273.1

Pivoting connecting clamps
for linear actuators

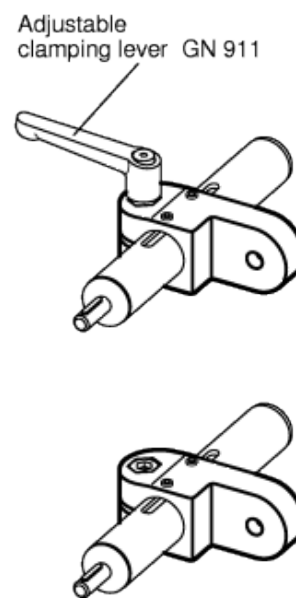
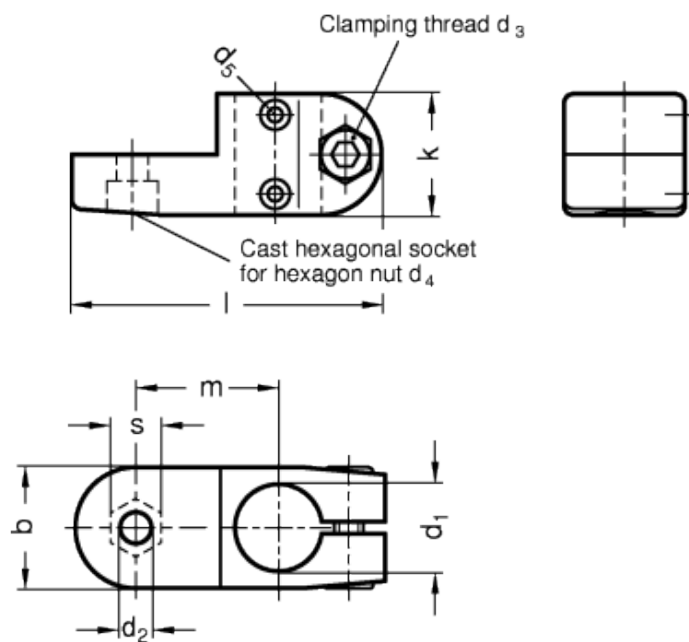

technical informations

Material
Aluminium.

Finish

Version SW: RAL 9005 black colour, matte finish, epoxy resin coating.

Clamping screws

- Identification no. 1: with clamping screw DIN 912 and nut DIN 985, zinc-plated.

- Identification no. 2: with AISI 304 stainless steel-clamping screw DIN 912 and nut DIN 985.

Assembly

The standard clamping bolts are socket cap screws DIN 912, supplied assembled. They can be replaced by clamping kits GN 911 (description see table of dimensions).

Features and applications

Linear actuator connectors GN 273.1 are normally supplied only in connection with a mounted linear actuator and for function control.

By means of the clamping screw on the guide bore d_1 the movement can either be set or the linear actuator connector can be clamped (after setting of final adjustment).

Accessory

- Tubings GN 990.
- Linear actuators GN 291.
- Linear actuators GN 292.
- Clamping kits [GN 911](#) (clamping handles GN 300.1 with distance bushing).

Standard Elements	Main dimensions											Clamping kits	Weight	
	Description	d_1 Bore without sliding bush	d_1 Bore with sliding bush	b	d_2	d_3	d_4	d_5	k	l	m			s
GN 273.1-B18-1-SW	B 18	-	25	6.5	M 6	M 6	M 6	M 3	25	64	29.5	10	GN 911-M6-22	55
GN 273.1-G18-1-SW	-	G 18	25	6.5	M 6	M 6	M 6	M 3	25	64	29.5	10	GN 911-M6-22	52
GN 273.1-B18-2-SW	B 18	-	25	6.5	M 6	M 6	M 6	M 3	25	64	29.5	10	GN 911-M6-22	55
GN 273.1-G18-2-SW	-	G 18	25	6.5	M 6	M 6	M 6	M 3	25	64	29.5	10	GN 911-M6-22	53



STANDARD MACHINE ELEMENTS WORLDWIDE