

## Cam roller carriages

for cam roller linear guide rails GN 2422

### SPECIFICATION

#### Types

- Type **N**: Normal roller carriage, central arrangement
- Type **R**: Radial roller carriage, lateral arrangement
- Type **S**: Narrow roller carriage, central arrangement

#### Version

- Version **U**: with wiper for floating bearing rail (U-rail)
- Version **X**: with wiper for fixed bearing rail (X-rail)

#### Base body

- Aluminium (Type N)
- Steel, zinc plated, blue passivated (Type R / Type S)

#### Rollers

- Anti-friction bearing steel, hardened
- Ball mounted, sealed (2RS)
- permanent lubrication

#### Wiper

- Plastic, PUR, grey
- Steel insert, zinc plated



### INFORMATION

Cam roller carriages GN 2424 are combined with cam roller linear guide rails GN 2422 (see page 654) to build linear guide rail systems. They are used in mechanical engineering or jigmaking for the linear movement of plant equipment.

Depending on cam roller carriage type, these can be mounted in axial or radial direction to the roller axes. Also depending on rail type, matching wipers are mounted, with type N featuring additional sealing lips in longitudinal direction.

- Linear guide rail systems (see page 660)

### ON REQUEST

- Cam roller carriages with more than 3 rollers
- other roller arrangements

### ASSEMBLY INFORMATION

The initial tension or the clearance of the cam roller carriage in the rail can be determined during assembly. Both outer rollers carry the cam roller carriage, with the middle roller (for eccentric adjustment) supporting the carriage on the opposing rail side. Detailed assembly instructions and the necessary tool are included with every cam roller carriage.

If required, the open-end wrench may also be ordered separately GN 2424.1 with two sizes being available:

$A/F_1 / A/F_2 = 8$  for construction size with  $h_1 = 18$ , Article no. **GN 2424.1-8-8**  
 $A/F_1 = 13$  and  $A/F_2 = 15$  for construction size with  $h_1 = 28 / 35 / 43$ , Article no. **GN 2424.1-13-15**

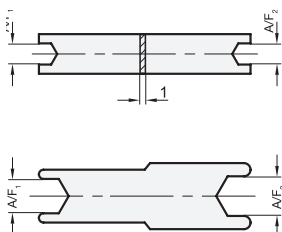
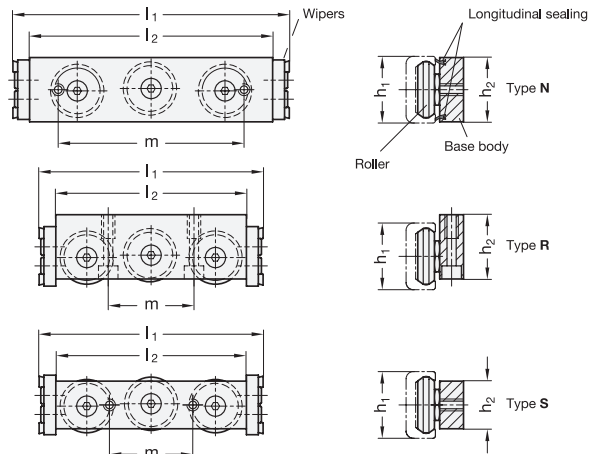

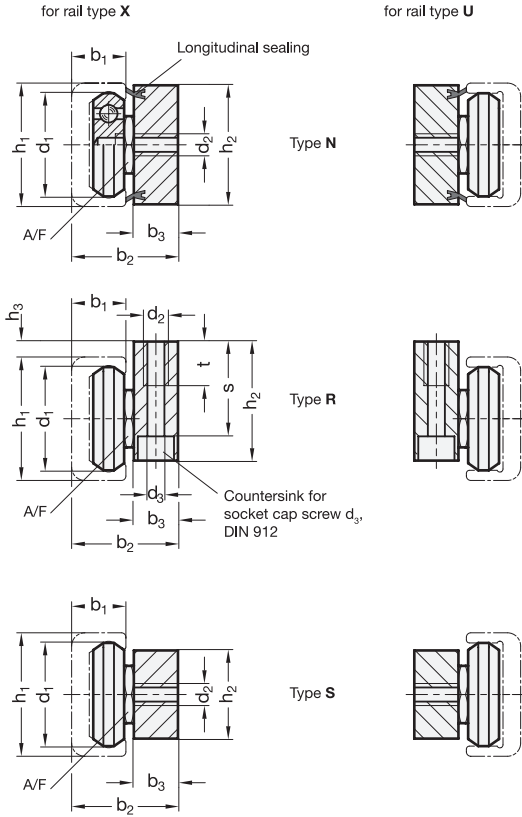

GN 2424

Description	h1	b1	b2	b3	d1	d2	d3	h2	h3	l1	l2	m	s	t	A/F	
GN 2424-18-N-X	18	8.3	16.5	7.2	14	M5	-	17	-	76	62	52	-	-	8	30
GN 2424-18-N-U	18	8.3	16.5	7.2	14	M5	-	17	-	76	62	52	-	-	8	30
GN 2424-28-N-X	28	12.3	24.1	10	22.4	M6	-	25	-	116	102	78	-	-	13	120
GN 2424-28-N-U	28	12.3	24.1	10	22.4	M6	-	25	-	116	102	78	-	-	13	120
GN 2424-43-N-X	43	21	37.5	15	35	M8	-	40	-	148	134	114	-	-	15	415
GN 2424-43-N-U	43	21	37.5	15	35	M8	-	40	-	148	134	114	-	-	15	415
GN 2424-18-R-X	18	8.3	17.3	8	14	M5	M4	20	4	74	60	20	17	8	8	86
GN 2424-18-R-U	18	8.3	17.3	8	14	M5	M4	20	4	74	60	20	17	8	8	86
GN 2424-28-R-X	28	12.3	24.1	10	22.4	M6	M5	30	4	94	80	36	24.5	10	13	240
GN 2424-28-R-U	28	12.3	24.1	10	22.4	M6	M5	30	4	94	80	36	24.5	10	13	240
GN 2424-35-R-X	35	16.5	37.5	12	28	M8	M6	36	3	114	100	45	29.5	15	15	486
GN 2424-35-R-U	35	16.5	37.5	12	28	M8	M6	36	3	114	100	45	29.5	15	15	486
GN 2424-43-R-X	43	21	37.5	15	35	M8	M6	45	4	134	120	56	38.5	16	15	697
GN 2424-43-R-U	43	21	37.5	15	35	M8	M6	45	4	134	120	56	38.5	16	15	697
GN 2424-18-S-X	18	8.3	15	5.7	14	M5	-	9.5	-	74	60	20	-	-	8	40
GN 2424-18-S-U	18	8.3	15	5.7	14	M5	-	9.5	-	74	60	20	-	-	8	40
GN 2424-28-S-X	28	12.3	23.8	9.7	22.4	M5	-	15	-	94	80	35	-	-	13	146
GN 2424-28-S-U	28	12.3	23.8	9.7	22.4	M5	-	15	-	94	80	35	-	-	13	146
GN 2424-35-S-X	35	16.5	30	12	28	M6	-	20	-	114	100	45	-	-	15	368
GN 2424-35-S-U	35	16.5	30	12	28	M6	-	20	-	114	100	45	-	-	15	368
GN 2424-43-S-X	43	21	37.5	14.5	35	M8	-	25	-	134	120	55	-	-	15	542
GN 2424-43-S-U	43	21	37.5	14.5	35	M8	-	25	-	134	120	55	-	-	15	542

