

Telescopic linear slides

with H-shaped rail

SPECIFICATION

Types

- Type **GG**: Runner with thread, on both sides
- Type **DG**: Runner 1x with countersunk and 1x with thread
- Type **DD**: Runner with countersunk, on both sides

Rail / Runner
Heat treatable steel

- zinc plated, blue passivated
- Raceways hardened

Balls
Anti-friction bearing steel, hardened

Ball cage
Steel, zinc plated

Rail connection

- Blank rivets, Stainless Steel ($h_1 = 28$ and 35)
- Screws, Steel zinc plated ($h_1 = 43$)



INFORMATION

Telescopic linear slides GN 2408 consist of two interconnected linear slides. They are used, for example, in handling or automation applications and in jigmaking, for straight-line traversal distance when large extension and a low construction height of the rail are required. The H-shape of the rails profile gives the configuration a high degree of sturdiness.

The rails and runners are equal in length. Both rails can be extended so that an extension is reached which is longer than the base length l_1 . Removing the support screws from the rails allows a stroke of the runners on both sides.

External elements should limit the maximum sliding distance; the supports of the rail have been designed to guard against the inadvertent extraction of the runner from the rail.

- Load rating and information to linear guide rail systems (see page 649)

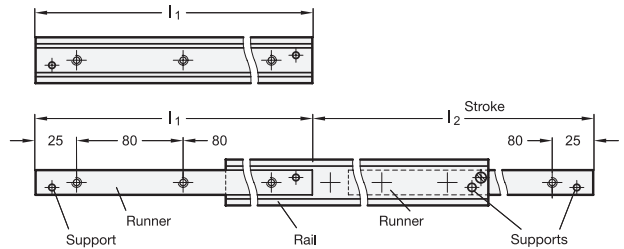

ON REQUEST

- other lengths (based on the standard lengths grid dimension of 80 mm)
- Special lengths (bore, start and end distances)

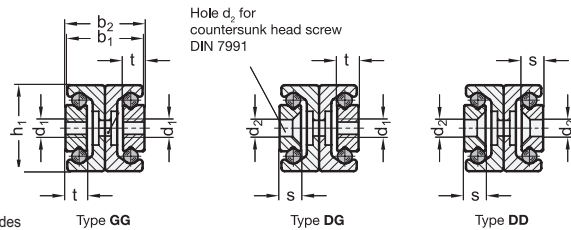

* Complete with type index of the telescopic linear slide (GG, DG or DD)

GG with thread, on both sides **DG** 1x with countersunk, 1x with thread **DD** with countersunk, on both sides

GN 2408

Description	h1	l1 - l2	b1	b2	d1	d2	s	t	⚖
GN 2408-28-210-*	28	210 - 232	24.6	25.8	M 5	5.5	4	7	920
GN 2408-28-370-*	28	370 - 380	24.6	25.8	M 5	5.5	4	7	1630
GN 2408-28-450-*	28	450 - 464	24.6	25.8	M 5	5.5	4	7	1980
GN 2408-28-530-*	28	530 - 548	24.6	25.8	M 5	5.5	4	7	2330
GN 2408-35-370-*	35	370 - 406	33	34	M 6	6.5	3.5	10	2260
GN 2408-35-450-*	35	450 - 494	33	34	M 6	6.5	3.5	10	2750
GN 2408-35-530-*	35	530 - 558	33	34	M 6	6.5	3.5	10	3220
GN 2408-35-610-*	35	610 - 646	33	34	M 6	6.5	3.5	10	3720
GN 2408-43-450-*	43	450 - 486	42	44	M 8	8.5	4.5	13.5	4730
GN 2408-43-610-*	43	610 - 626	42	44	M 8	8.5	4.5	13.5	6410
GN 2408-43-770-*	43	770 - 796	42	44	M 8	8.5	4.5	13.5	8090
GN 2408-43-930-*	43	930 - 966	42	44	M 8	8.5	4.5	13.5	9770

Weight type GG



Load rating of telescopic linear slides

in ascending order of the standard numbers

When selecting a suitable linear slide, it is primarily the available space, the desired stroke and the load carried which must be taken into consideration. The values listed below are intended as guidelines for selecting the most suitable nominal rail size.

The details on load rating are non-binding guide values given without liability and does not constitute any type of guarantee or warranty of its intended use. The user must determine in each individual case whether a product is suitable for the intended application. Environmental factors and aging may affect the stated values.

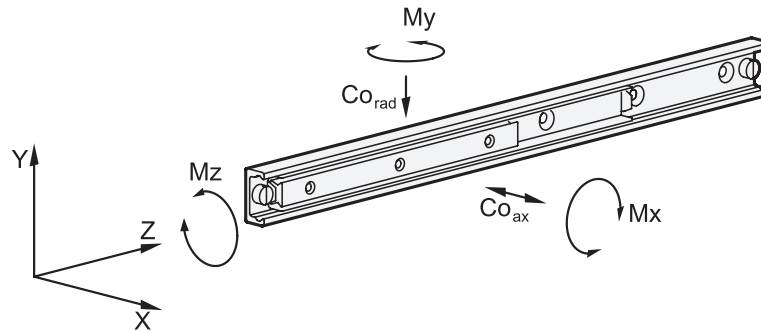

Static load rating

Article No.		Load ratings		Permissible load torques		
		Co _{rad} in N	Co _{ax} in N	M _x in Nm	M _y in Nm	M _z in Nm
GN 2402	-28-60-...	3580	2500	37	25	18
	-28-80-...	4780	3345	65	45	23
	-28-130-...	7765	5435	166	117	38
	-28-210-...	12545	8780	430	300	62
	-35-130-...	9980	6985	219	156	50
	-35-210-...	16125	11290	560	397	87
	-35-290-...	22270	15590	1085	745	109
	-43-210-...	23140	16200	790	552	157
GN 2404	-43-370-...	40775	28540	2445	1710	275
	-28-130	645	452	30	23	17
	-28-210	1165	816	86	60	27
	-28-290	2015	1410	190	135	41
	-28-370	2540	1780	309	215	52
	-28-450	3065	2145	540	316	64
	-28-530	3595	2515	625	435	74
	-35-290	2100	1470	218	155	56
	-35-370	2685	1880	348	247	69
	-35-450	3270	2285	515	365	80
	-35-530	4350	3045	787	553	101
	-35-610	4930	3450	1025	722	113
	-35-690	5510	3860	1295	914	125
	-43-370	3540	2480	444	313	119
	-43-450	4905	3435	735	514	151
-43-530	6305	4415	1090	766	184	
-43-610	7725	5410	1525	1065	210	
-43-690	8185	5730	1850	1295	240	
-43-770	9490	6530	2405	1685	273	



Load rating of telescopic linear slides

in ascending order of the standard series numbers

Article No.	Load ratings Co _{rad} in N	Article No.	Load ratings Co _{rad} in N	Article No.	Load ratings Co _{rad} in N
GN 2406	-28-290-E 587	GN 2408	-28-210-... 447	GN 2410	-28-210 444
	-28-370-E 793		-28-370-... 1000		-28-370 496
	-28-450-E 999		-28-450-... 1205		-28-450 405
	-28-530-E 1205		-28-530-... 1140		-28-530 342
	-28-610-E 1510		-35-370-... 1035		-35-370 534
	-35-450-E 1265		-35-450-... 1265		-35-450 439
	-35-530-E 1700		-35-530-... 1705		-35-530 403
	-35-690-E 2150		-35-610-... 1930		-35-610 346
	-35-850-E 2830		-43-450-... 1890		-43-450 1370
	-43-530-E 2140		-43-610-... 3035		-43-610 1115
	-43-690-E 2885		-43-770-... 3145		-43-770 870
	-43-850-E 4010		-43-930-... 2580		-43-930 714
	-43-1010-E 4755				
	-43-1490-E 3820				

No details on the permissible load torques are given for the telescopic linear slides as these are normally used for paired applications. Loads of these dimensions occur to a minor degree because it may be assumed that the surrounding construction has sufficient rigidity and stiffness. Transferring load torques within certain limited is permitted.

Static load and deflection

The load values given in the tables refer to a maximum permissible force allowed to act in the middle of the fully extended profile rail at the third segment. If the given values are observed and if the telescopic linear slide is fully extended, a minor deflection (sag) occurs at the end of the runner or of the rail. This has normally no detrimental effect on the proper function of the application. If required, guide values may be given if requested.

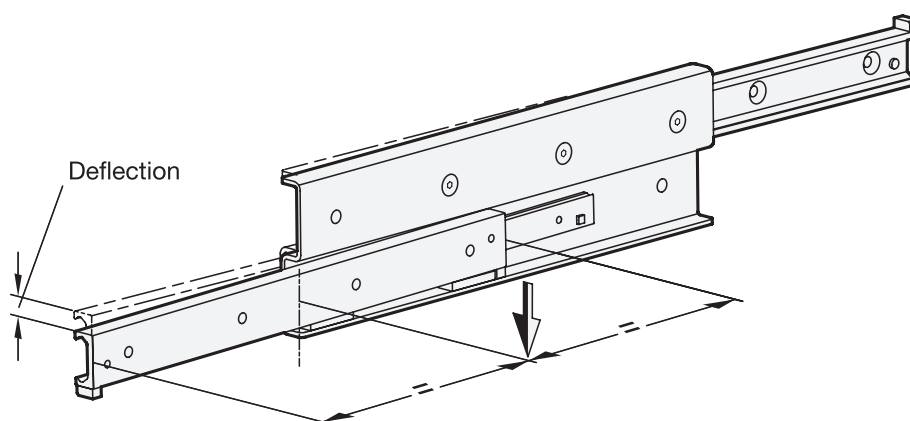

Mounting screws, assignment of the mounting holes

The standard mounting hardware is DIN 7991-10.9 countersunk head screws, to be mounted with the recommended tightening torque. Depending on type, not all mounting holes may be utilized. In general, these holes can be left unused. In exceptional cases, especially in bilateral stroke, mounting holes can be accessed by loosening the support screws and by pulling out the runner. The support screws are then put back in place.

Traversal speed, cage slip

The traversal speed in linear slides can be as much as 0.8 m/s. The particular application and the installation length can have an effect on this value. In the event of rapid changes of direction and high accelerating forces, cage slip may occur in some cases, especially in long ball cages. In cases such as these, the cage does not move synchronously with half the speed of the runner, but gradually loses its correct position owing to the slip. Whenever possible, running a blank stroke to the end of the traversal distance should be provided for back positioning.



Linear guide rail systems

Structure

Linear guide rail systems allow the reliable and economical linear movement of hardware modules. Their outstanding attributes are low-maintenance operation, long service life and quiet running. These are attributes which make roller guide systems indispensable components for efficient and safe movement of devices, and meet the needs of facilities with low energy requirements.

The product range includes all components necessary for constructing linear guide rail systems that are compact and easy to assemble and install. All linear guide rail systems consist of one outer rail with rollers or roller carriages moving inside the rail.

Rails are the foundations for linear guide rail systems. They can be constructed as fixed or floating bearing versions, with the fixed bearing type guiding the rollers running inside the rail on two levels, while the floating bearing type does so only on one level. By combining both versions, any misalignments or parallelism errors in the connected construction can be corrected. Complex preliminary work caused by the precision machining of surrounding parts can thus be kept to a minimum. Both rail versions can be mounted in one of two ways: cylindrical countersunk holes, or 90° conical holes for self-centering.

Cam roller carriages are available in 3 different types of designs, differing by their radial or axial assembly arrangement, their material, and their degree of sealing. All cam roller carriages consist of 3 rollers, with the middle one always supplied with an eccentrically adjustable bearing pivot for determining the initial tension or the clearance/play inside the rail. Depending on the rail version, a wiper is mounted on either end of the roller carriage.

Cam rollers are similar in structure to deep-groove ball bearings, with a non-detachable bearing pivot used as mounting point.

For special applications, cam rollers and wipers can also be supplied separately from the cam roller carriages under separate standards.

All design variants are available in the nominal rail dimensions $h_1 = 18, 28, 35$ and 43 mm. Beyond the standard range, they can also be supplied in lengths of up to 3600 mm in one piece, or as combined rails for individual and customized requirements.

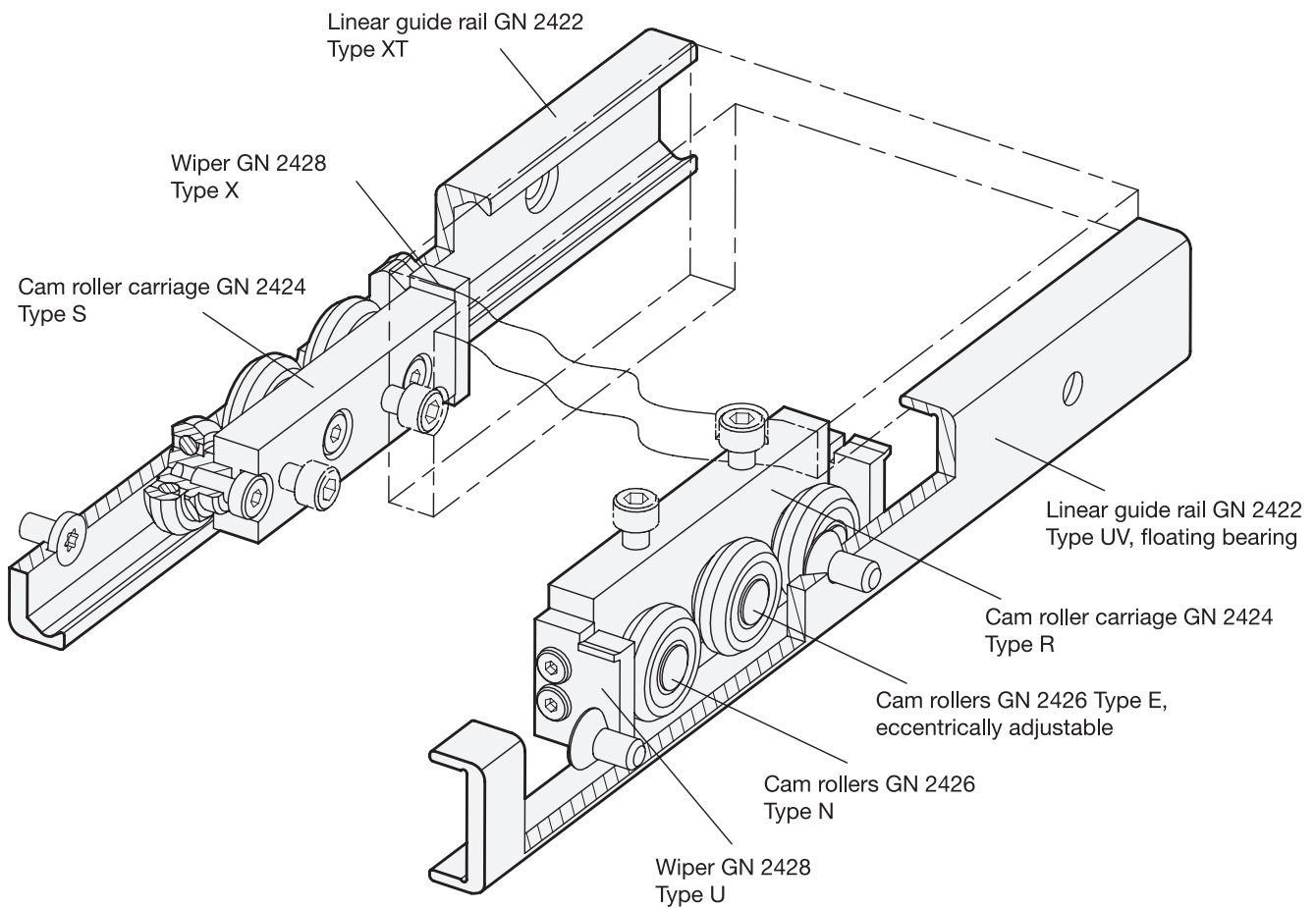



Control elements 6

Linear guide rail systems

Components and extras

To insure maximum flexibility, linear guide rail systems are made from the components listed below. Depending on the requirement, the appropriate components can be supplied in the desired quantity. Because the linear guide rails and the cam roller carriages must be assembled separately in many applications, these items will be supplied unassembled and packed separately.

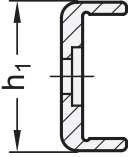
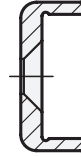
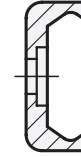
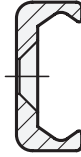
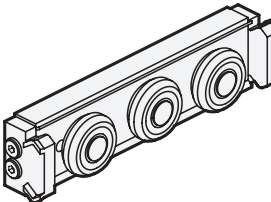
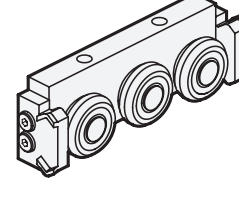
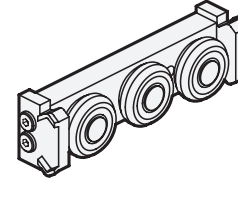
Upon request, fully pre-assembled linear guide rail systems including rails GN 2422 and cam roller carriages GN 2424 are available.

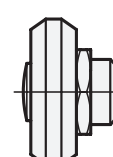
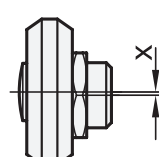
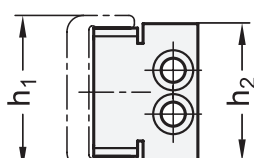
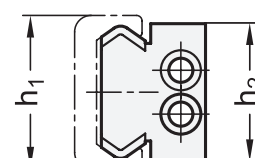
<p>Cam roller linear guide rails GN 2422 (see page 654)</p>	<div style="display: flex; justify-content: space-around;"> <div style="text-align: center;"> <p>Type UT</p>  <p>h₁</p> </div> <div style="text-align: center;"> <p>Type UV</p>  </div> <div style="text-align: center;"> <p>Type XT</p>  </div> <div style="text-align: center;"> <p>Type XV</p>  </div> </div> <div style="display: flex; justify-content: space-around; margin-top: 10px;"> <p>Floating bearing rails</p> <p>Fixed bearing rails</p> </div>
<p>Cam roller carriages for rails GN 2424 (see page 656)</p>	<div style="display: flex; justify-content: space-around;"> <div style="text-align: center;"> <p>Type N</p>  <p>Normal cam roller carriages</p> </div> <div style="text-align: center;"> <p>Type R</p>  <p>Radial cam roller carriages</p> </div> <div style="text-align: center;"> <p>Type S</p>  <p>Narrow cam roller carriages</p> </div> </div>
<p>Cam rollers for rails GN 2426 (see page 658)</p>	<div style="display: flex; justify-content: space-around;"> <div style="text-align: center;"> <p>Type B</p>  <p>Roller with bore</p> </div> <div style="text-align: center;"> <p>Type N</p>  <p>Normal roller with centered bearing mounting point</p> </div> <div style="text-align: center;"> <p>Type E</p>  <p>x</p> <p>Eccentric roller with eccentric bearing mounting point</p> </div> </div>
<p>Wipers for rails GN 2428 (see page 659)</p>	<div style="display: flex; justify-content: space-around;"> <div style="text-align: center;"> <p>Type U</p>  <p>h₁ h₂</p> <p>for fixed bearing rails</p> </div> <div style="text-align: center;"> <p>Type X</p>  <p>h₁ h₂</p> <p>for floating bearing rails</p> </div> </div>

Linear guide rail systems

Assembly examples

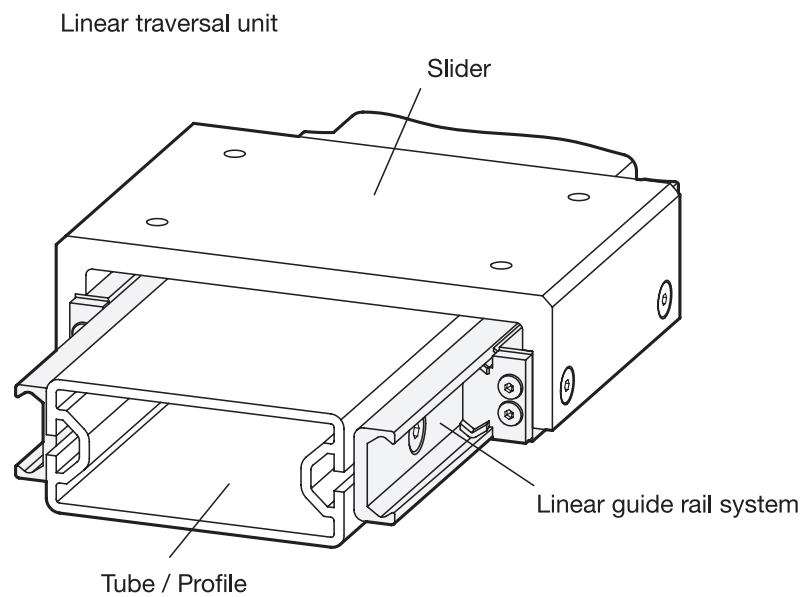
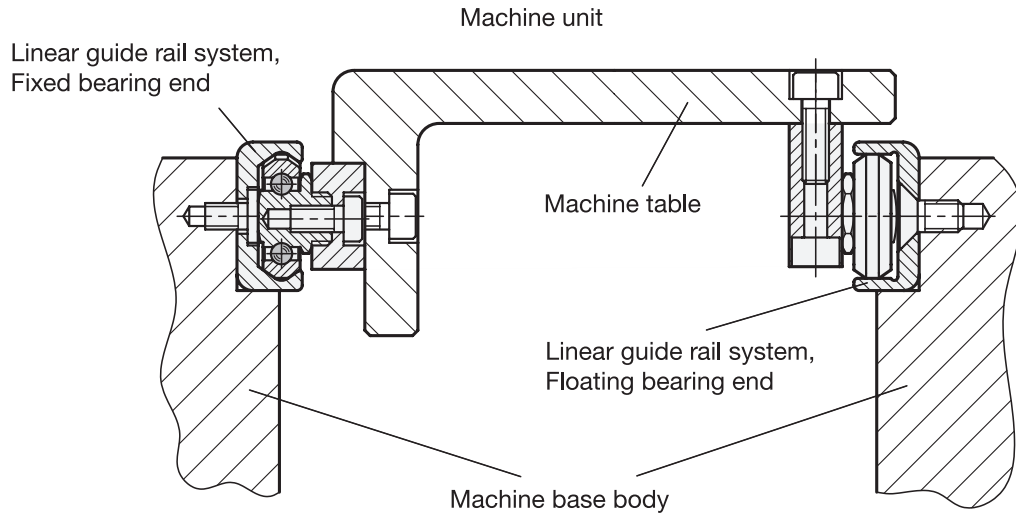

Control elements 6