

GN 237-NI

Hinges

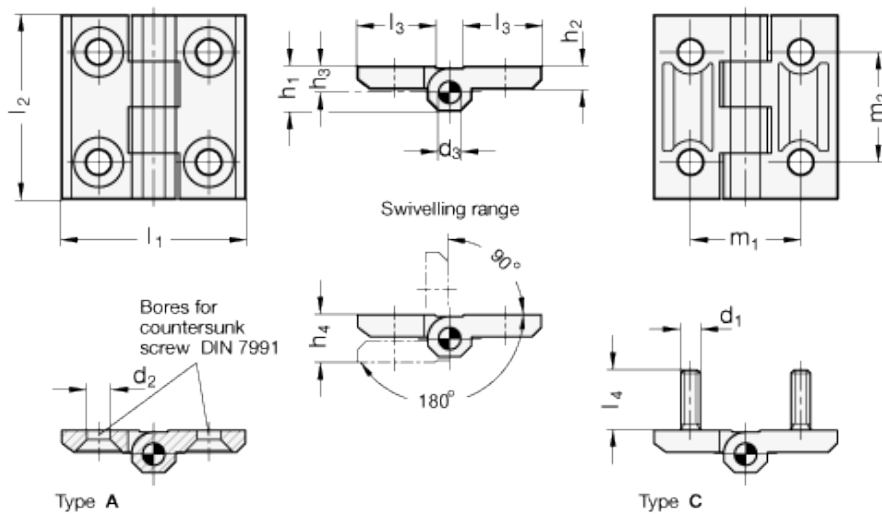

INOX
Stainless Steel



technical informations

Material

AISI CF-8 stainless steel NI.

Finish

Sand-blasted, matte finish GS.

Rotation pin

AISI 316Ti stainless steel (A4).

Assembly

- Type A: 2x2 bores for countersunk screws.

Rotation angle

Max. 270°, between 0° and -90° and between 0° and 180°.

Standard Elements	Main dimensions											Through holes			Weight
Description	l_1	l_2	d_3	h_1	h_2	h_3	$h_{4+0.5}$	l_3	m_1	m_2	d_1	l_4	d_2	g	
GN 237-NI-30-30-A-GS	30	30	3	7.5	4	4.5	8.5	10.7	18	18	-	-	4.3	25	
GN 237-NI-40-40-A-GS	40	40	4	9	5	5.5	11	16	25	25	-	-	5.3	58	
GN 237-NI-50-50-A-GS	50	50	6	11.5	6	6.5	13	21	30	30	-	-	6.4	107	
GN 237-NI-60-60-A-GS	60	60	8	15	8	8.5	17	26	36	36	-	-	8.3	203	
GN 237-NI-40-40-C-GS	40	40	4	9	5	5.5	11	16	25	25	M5	11	-	69	
GN 237-NI-50-50-C-GS	50	50	6	11.5	6	6.5	13	21	30	30	M6	13	-	128	
GN 237-NI-60-60-C-GS	60	60	8	15	8	8.5	17	26	36	36	M8	17	-	147	

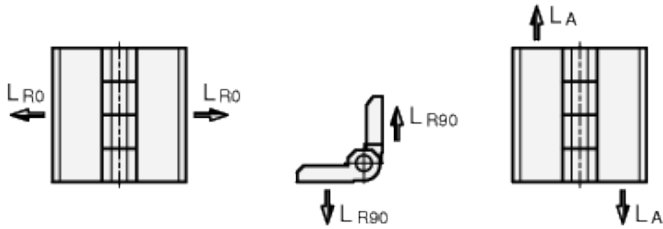

Standard Elements	Radial load in N		Axial load in N
	L_{R0}	L_{R90}	L_A
GN 237-NI-30-30-A-GS	1700	750	750
GN 237-NI-40-40-A-GS	4000	1650	2100
GN 237-NI-50-50-A-GS	6500	2250	2550
GN 237-NI-60-60-A-GS	10000	5000	5000



STANDARD MACHINE ELEMENTS WORLDWIDE