

Elastomer jaw couplings

with grub screw

SPECIFICATION

Bore codes

- Type **B**: without keyway
- Type **K**: with keyway (from $d_1 = 30$)

Hub

Aluminum **AL**
anodized, natural color

Coupling spider

Polyurethane (TPU)
temperature resistant up to 60 °C

Hardness

80 Shore A, blue **BS**
92 Shore A, white **WS**
98 Shore A, red **RS**

Grub screws

- Steel, blackened
- for $d_2 / d_3 \leq 4$, one grub screw
- for $d_2 / d_3 > 4$, two grub screws

Temperature range: -20 °C up to +60 °C



INFORMATION

Elastomer jaw couplings GN 2241 can transmit very high torques while compensating for shaft misalignments and runout tolerances. They are preferred in applications where the focus lies on pure torque and power transmission. The choice of three coupling spiders with different hardness values allows the properties of the coupling to be optimally matched to the specific requirements. The use of grub screws for clamping and the simple plug-in installation make jaw couplings very easy to assemble. With the bore code K, the keyway is always integrated into both bores d_2 and d_3 .

ACCESSORY

- Coupling spiders GN 2240.1 (see page)

TECHNICAL INFORMATION

- Keyway P9 DIN 6885 (see page A16)
- ISO-Fundamental Tolerances (see page A21)
- Elastomer characteristics (see page A32)

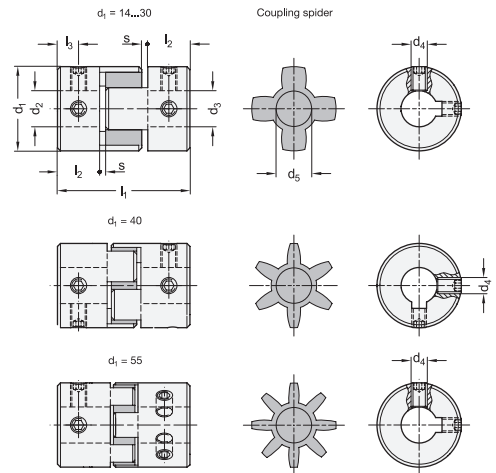

Assembly instruction

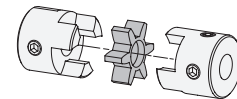

TECHNICAL VALUES

d1	Coupling spider	Shore hardness coupling spider	Rated torque in Nm	Max. torque in Nm	Max. speed (min ⁻¹)	Moment of inertia in kgm ²	Static torsional stiffness in Nm/rad	Max. shaft misalignment		
								lateral in mm	axial in mm	angular in °
14	BS	80A	0.7	1.4	45.000	2.0×10^{-7}	8	0.15	0.6	1
14	WS	92A	1.2	2.4	45.000	2.0×10^{-7}	14	0.1	0.6	1
14	RS	98A	2	4	45.000	2.0×10^{-7}	22	0.1	0.6	1
20	BS	80A	1.8	3.6	31.000	1.1×10^{-6}	16	0.2	0.8	1
20	WS	92A	3	6	31.000	1.1×10^{-6}	29	0.15	0.8	1
20	RS	98A	5	10	31.000	1.1×10^{-6}	55	0.1	0.8	1
30	BS	80A	4	8	21.000	6.2×10^{-6}	46	0.2	1	1
30	WS	92A	7.5	15	21.000	6.2×10^{-6}	73	0.15	1	1
30	RS	98A	12.5	25	21.000	6.2×10^{-6}	130	0.1	1	1
40	BS	80A	4.9	9.8	15.000	3.7×10^{-5}	380	0.15	1.2	1
40	WS	92A	10	20	15.000	3.7×10^{-5}	570	0.1	1.2	1
40	RS	98A	17	34	15.000	3.7×10^{-5}	1200	0.1	1.2	1
55	BS	80A	17	34	11.000	1.6×10^{-4}	1400	0.2	1.4	1
55	WS	92A	35	70	11.000	1.6×10^{-4}	1600	0.15	1.4	1
55	RS	98A	60	120	11.000	1.6×10^{-4}	2600	0.1	1.4	1

* Complete with shore hardness of the couplings (BS, RS, WS)

BS RS WS

GN 2241-B

Description	d1	d2 - d3 H8 recommended shaft tolerance h7	d4	l1	l2 recommended shaft insertion depth	l3	s recommended installation spacing	Tightening torque of the screw in Nm ≈	⚖
GN 2241-14-B3-3-AL-*	14	3-3	M 3	22	7	3.5	1	0.7	9
GN 2241-14-B3-4-AL-*	14	3-4	M 3	22	7	3.5	1	0.7	9
GN 2241-14-B3-5-AL-*	14	3-5	M 3	22	7	3.5	1	0.7	9
GN 2241-14-B3-6-AL-*	14	3-6	M 3	22	7	3.5	1	0.7	9
GN 2241-14-B4-4-AL-*	14	4-4	M 3	22	7	3.5	1	0.7	9
GN 2241-14-B4-5-AL-*	14	4-5	M 3	22	7	3.5	1	0.7	9
GN 2241-14-B4-6-AL-*	14	4-6	M 3	22	7	3.5	1	0.7	9
GN 2241-14-B5-5-AL-*	14	5-5	M 3	22	7	3.5	1	0.7	9
GN 2241-14-B5-6-AL-*	14	5-6	M 3	22	7	3.5	1	0.7	9
GN 2241-14-B6-6-AL-*	14	6-6	M 3	22	7	3.5	1	0.7	9
GN 2241-20-B5-5-AL-*	20	5-5	M 3	30	10	5	1	0.7	22
GN 2241-20-B5-6-AL-*	20	5-6	M 3	30	10	5	1	0.7	22
GN 2241-20-B5-8-AL-*	20	5-8	M 3	30	10	5	1	0.7	22
GN 2241-20-B6-6-AL-*	20	6-6	M 3	30	10	5	1	0.7	22
GN 2241-20-B6-8-AL-*	20	6-8	M 3	30	10	5	1	0.7	22
GN 2241-20-B8-8-AL-*	20	8-8	M 3	30	10	5	1	0.7	22
GN 2241-30-B8-8-AL-*	30	8-8	M 4	35	11	5.5	1.5	1.7	53
GN 2241-30-B8-10-AL-*	30	8-10	M 4	35	11	5.5	1.5	1.7	53
GN 2241-30-B8-12-AL-*	30	8-12	M 4	35	11	5.5	1.5	1.7	53
GN 2241-30-B8-14-AL-*	30	8-14	M 4	35	11	5.5	1.5	1.7	53
GN 2241-30-B10-10-AL-*	30	10-10	M 4	35	11	5.5	1.5	1.7	53
GN 2241-30-B10-12-AL-*	30	10-12	M 4	35	11	5.5	1.5	1.7	53
GN 2241-30-B10-14-AL-*	30	10-14	M 4	35	11	5.5	1.5	1.7	53
GN 2241-30-B12-12-AL-*	30	12-12	M 4	35	11	5.5	1.5	1.7	53
GN 2241-30-B12-14-AL-*	30	12-14	M 4	35	11	5.5	1.5	1.7	53
GN 2241-30-B14-14-AL-*	30	14-14	M 4	35	11	5.5	1.5	1.7	53
GN 2241-40-B12-12-AL-*	40	12-12	M 5	66	25	8.5	2	4	193
GN 2241-40-B12-14-AL-*	40	12-14	M 5	66	25	8.5	2	4	193
GN 2241-40-B12-15-AL-*	40	12-15	M 5	66	25	8.5	2	4	193
GN 2241-40-B12-16-AL-*	40	12-16	M 5	66	25	8.5	2	4	193
GN 2241-40-B14-14-AL-*	40	14-14	M 5	66	25	8.5	2	4	193
GN 2241-40-B14-15-AL-*	40	14-15	M 5	66	25	8.5	2	4	193
GN 2241-40-B14-16-AL-*	40	14-16	M 5	66	25	8.5	2	4	193
GN 2241-40-B15-15-AL-*	40	15-15	M 5	66	25	8.5	2	4	193
GN 2241-40-B15-16-AL-*	40	15-16	M 5	66	25	8.5	2	4	193
GN 2241-40-B16-16-AL-*	40	16-16	M 5	66	25	8.5	2	4	193
GN 2241-55-B18-18-AL-*	55	18-18	M 6	78	30	10.5	2	7	436
GN 2241-55-B18-19-AL-*	55	18-19	M 6	78	30	10.5	2	7	436
GN 2241-55-B18-20-AL-*	55	18-20	M 6	78	30	10.5	2	7	436
GN 2241-55-B18-25-AL-*	55	18-25	M 6	78	30	10.5	2	7	436
GN 2241-55-B19-19-AL-*	55	19-19	M 6	78	30	10.5	2	7	436
GN 2241-55-B19-20-AL-*	55	19-20	M 6	78	30	10.5	2	7	436
GN 2241-55-B19-25-AL-*	55	19-25	M 6	78	30	10.5	2	7	436
GN 2241-55-B20-20-AL-*	55	20-20	M 6	78	30	10.5	2	7	436
GN 2241-55-B20-25-AL-*	55	20-25	M 6	78	30	10.5	2	7	436
GN 2241-55-B25-25-AL-*	55	25-25	M 6	78	30	10.5	2	7	436

Weight type BS



Joins 10

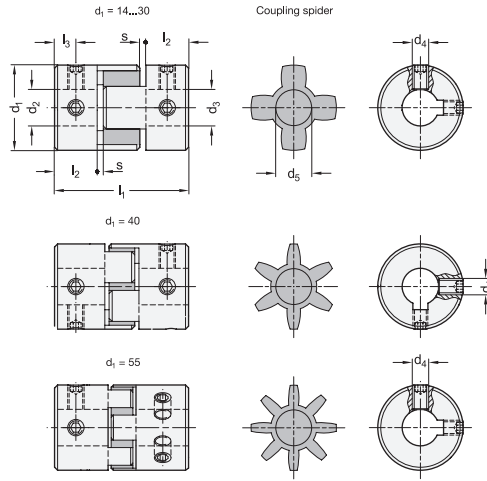

Assembly instruction

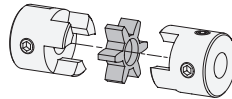

* Complete with shore hardness of the couplings (BS, RS, WS)

BS RS WS

GN 2241-K

Description	d1	d2 - d3 H8 recommended shaft tolerance h7	d4	l1	l2 recommended shaft insertion depth	l3	s recommended installation spacing	Tightening torque of the screw in Nm ≈	⚖
GN 2241-30-K8-8-AL-*	30	8-8	M 4	35	11	5.5	1.5	1.7	53
GN 2241-30-K8-10-AL-*	30	8-10	M 4	35	11	5.5	1.5	1.7	53
GN 2241-30-K8-12-AL-*	30	8-12	M 4	35	11	5.5	1.5	1.7	53
GN 2241-30-K8-14-AL-*	30	8-14	M 4	35	11	5.5	1.5	1.7	53
GN 2241-30-K10-10-AL-*	30	10-10	M 4	35	11	5.5	1.5	1.7	53
GN 2241-30-K10-12-AL-*	30	10-12	M 4	35	11	5.5	1.5	1.7	53
GN 2241-30-K10-14-AL-*	30	10-14	M 4	35	11	5.5	1.5	1.7	53
GN 2241-30-K12-12-AL-*	30	12-12	M 4	35	11	5.5	1.5	1.7	53
GN 2241-30-K12-14-AL-*	30	12-14	M 4	35	11	5.5	1.5	1.7	53
GN 2241-30-K14-14-AL-*	30	14-14	M 4	35	11	5.5	1.5	1.7	53
GN 2241-40-K12-12-AL-*	40	12-12	M 5	66	25	8.5	2	4	193
GN 2241-40-K12-14-AL-*	40	12-14	M 5	66	25	8.5	2	4	193
GN 2241-40-K12-15-AL-*	40	12-15	M 5	66	25	8.5	2	4	193
GN 2241-40-K12-16-AL-*	40	12-16	M 5	66	25	8.5	2	4	193
GN 2241-40-K14-14-AL-*	40	14-14	M 5	66	25	8.5	2	4	193
GN 2241-40-K14-15-AL-*	40	14-15	M 5	66	25	8.5	2	4	193
GN 2241-40-K14-16-AL-*	40	14-16	M 5	66	25	8.5	2	4	193
GN 2241-40-K15-15-AL-*	40	15-15	M 5	66	25	8.5	2	4	193
GN 2241-40-K15-16-AL-*	40	15-16	M 5	66	25	8.5	2	4	193
GN 2241-40-K16-16-AL-*	40	16-16	M 5	66	25	8.5	2	4	193
GN 2241-55-K18-18-AL-*	55	18-18	M 6	78	30	10.5	2	7	436
GN 2241-55-K18-19-AL-*	55	18-19	M 6	78	30	10.5	2	7	436
GN 2241-55-K18-20-AL-*	55	18-20	M 6	78	30	10.5	2	7	436
GN 2241-55-K18-25-AL-*	55	18-25	M 6	78	30	10.5	2	7	436
GN 2241-55-K19-19-AL-*	55	19-19	M 6	78	30	10.5	2	7	436
GN 2241-55-K19-20-AL-*	55	19-20	M 6	78	30	10.5	2	7	436
GN 2241-55-K19-25-AL-*	55	19-25	M 6	78	30	10.5	2	7	436
GN 2241-55-K20-20-AL-*	55	20-20	M 6	78	30	10.5	2	7	436
GN 2241-55-K20-25-AL-*	55	20-25	M 6	78	30	10.5	2	7	436
GN 2241-55-K25-25-AL-*	55	25-25	M 6	78	30	10.5	2	7	436

Weight type BS

