

Tension levers

Steel / Stainless Steel

SPECIFICATION

Types

- Type **C**: Angled lever with plain bore H7
- Type **E**: Angled lever with threaded bore
- Type **B***: Straight lever with plain bore H7
- Type **D***: Straight lever with threaded bore

* not available from stock, requires a minimum order quantity

Version in Steel, blackened

Ball knobs DIN 319 (see page 538)
Plastic, Duroplast
black, shiny finish

Version in Stainless Steel AISI 303 NI

- matt shot-blasted
- only type E

Ball knobs DIN 319 (see page 538)
Plastic, Duroplast
black, shiny finish



INFORMATION

Tension levers GN 212 are used as clamping element as well as operating levers.

TECHNICAL INFORMATION

- Cross holes GN 110 (see page A17)
- ISO Fundamental Tolerances (see page A21)
- Stainless Steel characteristics (see page A26)

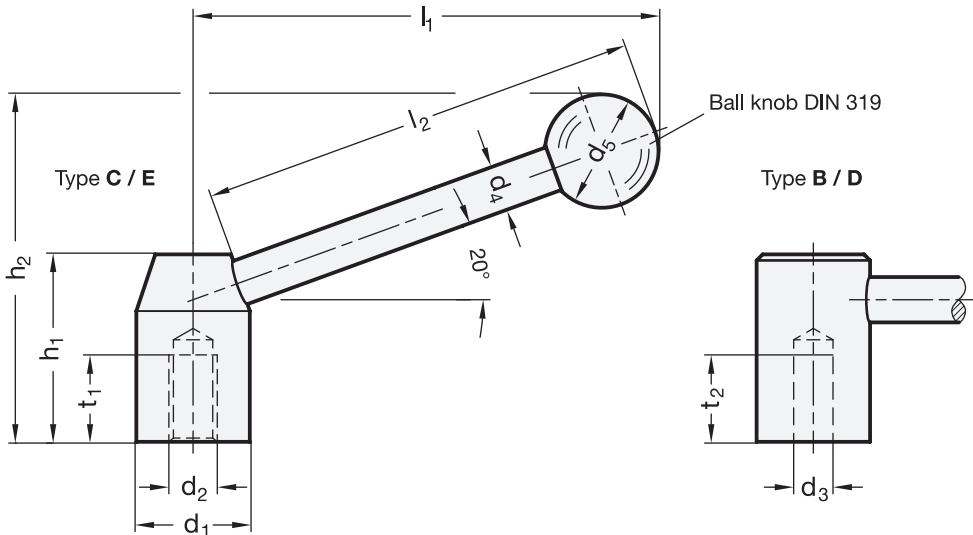



GN 212-ST

Description	d1	d2	d3 H7	d4	d5	h1	h2 ≈	l1 ≈	l2	t1 min.	t2 min.	⚖️
GN 212-22-B10-B	22	-	B 10	8	20	37	40.5	96	85	-	19	127
GN 212-25-B12-B	25	-	B 12	10	25	42	47	107.5	95	-	21	195
GN 212-28-B12-B	28	-	B 12	12	30	47	53	122	108	-	23	294
GN 212-32-B16-B	32	-	B 16	12	32	52	59	142	126	-	28	382
GN 212-36-B16-B	36	-	B 16	14	35	58	64.5	156	138	-	28	580
GN 212-40-B20-B	40	-	B 20	16	40	64	72	174	154	-	30	778
GN 212-22-B10-C	22	-	B 10	8	20	37	67	89.5	85	-	19	114
GN 212-25-B12-C	25	-	B 12	10	25	42	76	100.5	95	-	21	174
GN 212-28-B12-C	28	-	B 12	12	30	47	87	114	108	-	23	275
GN 212-32-B16-C	32	-	B 16	12	32	52	98	133	126	-	28	349
GN 212-36-B16-C	36	-	B 16	14	35	58	108	146	138	-	28	500
GN 212-40-B20-C	40	-	B 20	16	40	64	120	162.5	154	-	30	724
GN 212-22-M10-D	22	M 10	-	8	20	37	40.5	96	85	15	-	131
GN 212-25-M12-D	25	M 12	-	10	25	42	47	107.5	95	18	-	203
GN 212-28-M12-D	28	M 12	-	12	30	47	53	122	108	18	-	296
GN 212-32-M16-D	32	M 16	-	12	32	52	59	142	126	23	-	385
GN 212-36-M16-D	36	M 16	-	14	35	58	64.5	156	138	24	-	503
GN 212-40-M20-D	40	M 20	-	16	40	64	72	174	154	27	-	261
GN 212-22-M10-E	22	M 10	-	8	20	37	67	89.5	85	15	-	118
GN 212-25-M12-E	25	M 12	-	10	25	42	76	100.5	95	18	-	182
GN 212-28-M12-E	28	M 12	-	12	30	47	87	114	108	18	-	274
GN 212-32-M16-E	32	M 16	-	12	32	52	98	133	126	23	-	352
GN 212-36-M16-E	36	M 16	-	14	35	58	108	146	138	24	-	525
GN 212-40-M20-E	40	M 20	-	16	40	64	120	162.5	154	27	-	709

GN 212-NI

STAINLESS STEEL

Description	d1	d2	d4	d5	h1	h2 ≈	l1 ≈	l2	t1 min.	⚖️
GN 212-22-M8-E-NI	22	M 8	8	20	37	67	89.5	85	18	121
GN 212-25-M10-E-NI	25	M 10	10	25	42	76	100.5	95	18	186
GN 212-28-M12-E-NI	28	M 12	12	30	47	87	114	108	20	272
GN 212-32-M16-E-NI	32	M 16	12	32	52	98	133	126	25	340