

GN 212.5

Adjustable handles

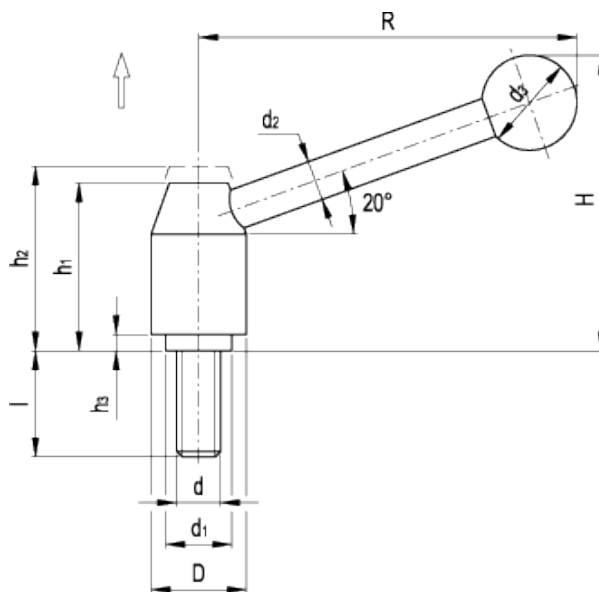

INOX
Stainless Steel



technical informations

Lever body

Matte shot-blasted AISI 303 stainless steel.

Handle

Matte shot-blasted AISI 303 stainless steel arm inclined by a 20° angle (version e)
DIN 319 black phenolic based (PF) Duroplast ball knob.

Clamping element

AISI 303 stainless steel threaded stud with toothed element for coupling to the lever body, stainless steel return spring.

Features and applications

GN 212.5 adjustable handles are used for applications having a limited space or where a particular handle position is required. Stainless steel, thanks to its high resistance to corrosion, allows the application of these adjustable handles on machines and

equipment in those sectors where laws or particular hygienic, climatic and environmental factors make it mandatory to use corrosion resistant materials.

Instructions of use

The threaded stud is connected to the handle via serrations and can be easily disengaged. By pulling the handle, the internal mechanism disengages the serrations and allows the handle to swivel to the ideal clamping position. By releasing the handle, the mechanism automatically re-engages serrations.

Standard Elements	Main dimensions									Threaded stud		Weight
Description	D	R	H \approx	h ₁	h ₂	h ₃	d ₁	d ₂	d ₃	d	h	g
GN 212.5-21-M8-16-E	21	75	59	33.5	37.5	1	13.5	8	20	M8	16	104
GN 212.5-21-M8-20-E	21	75	59	33.5	37.5	1	13.5	8	20	M8	20	105
GN 212.5-21-M8-25-E	21	75	59	33.5	37.5	1	13.5	8	20	M8	25	107
GN 212.5-21-M8-32-E	21	75	59	33.5	37.5	1	13.5	8	20	M8	32	109
GN 212.5-21-M8-40-E	21	75	59	33.5	37.5	1	13.5	8	20	M8	40	112
GN 212.5-21-M8-50-E	21	75	59	33.5	37.5	1	13.5	8	20	M8	50	114
GN 212.5-21-M8-63-E	21	75	59	33.5	37.5	1	13.5	8	20	M8	63	119
GN 212.5-24-M10-20-E	24	101	75	40	44.5	2.5	16	10	25	M10	20	173
GN 212.5-24-M10-25-E	24	101	75	40	44.5	2.5	16	10	25	M10	25	175
GN 212.5-24-M10-32-E	24	101	75	40	44.5	2.5	16	10	25	M10	32	178
GN 212.5-24-M10-40-E	24	101	75	40	44.5	2.5	16	10	25	M10	40	182
GN 212.5-24-M10-50-E	24	101	75	40	44.5	2.5	16	10	25	M10	50	188
GN 212.5-24-M10-63-E	24	101	75	40	44.5	2.5	16	10	25	M10	63	195
GN 212.5-24-M10-80-E	24	101	75	40	44.5	2.5	16	10	25	M10	80	202
GN 212.5-28-M12-25-E	28	116	88	48.5	53	4.5	19	12	30	M12	25	295
GN 212.5-28-M12-32-E	28	116	88	48.5	53	4.5	19	12	30	M12	32	300
GN 212.5-28-M12-40-E	28	116	88	48.5	53	4.5	19	12	30	M12	40	305
GN 212.5-28-M12-50-E	28	116	88	48.5	53	4.5	19	12	30	M12	50	312
GN 212.5-28-M12-63-E	28	116	88	48.5	53	4.5	19	12	30	M12	63	322
GN 212.5-28-M12-80-E	28	116	88	48.5	53	4.5	19	12	30	M12	80	333



STANDARD MACHINE ELEMENTS WORLDWIDE