

GN 212.3

Adjustable tension handles

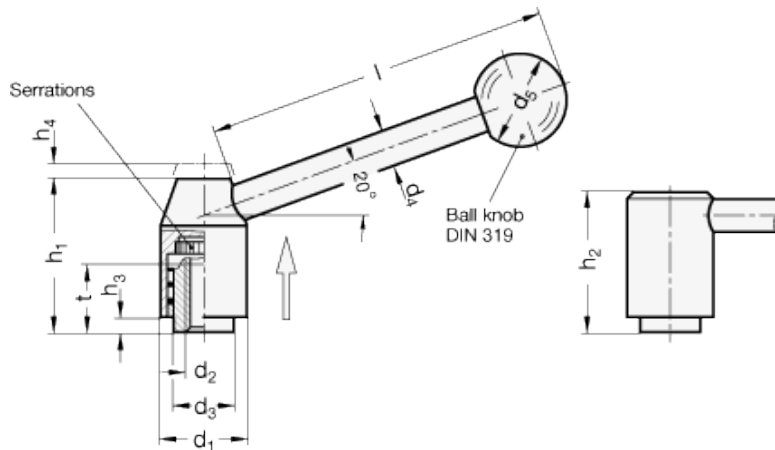

technical informations

Lever body

Black-oxide turned steel.

Handle

Black-oxide turned steel arm with [DIN 319](#) black phenolic based (PF) Duroplast ball knob.

- Version D: with straight arm.
- Version E: with inclined arm by a 20° angle.

Clamping element

Black-oxide steel with threaded hole and toothed element for coupling to the lever body, steel return spring.

Instructions of use

The threaded bushing is connected to the handle via serrations and can be easily disengaged. By pulling the handle, the internal mechanism disengages the serrations and allows the handle to swivel to the ideal clamping position. By releasing the handle, the mechanism automatically re-engages serrations.

Features and applications

GN 212.3 adjustable tension handles are used for applications having a limited space or where a particular position is required.

Standard Elements	Main dimensions									Mounting hole		Weight
	Description	d ₁	h ₁	h ₂	h ₃	h ₄	d ₃	d ₄	d ₅	l	d ₂	
GN 212.3-21-M6-D	21	33.5	37.5	1	-	13.5	8	20	70	M6	11	97
GN 212.3-21-M6-E	21	-	-	1	31	13.5	8	20	70	M6	11	97
GN 212.3-21-M8-D	21	33.5	37.5	1	-	13.5	8	20	70	M8	11	95
GN 212.3-21-M8-E	21	-	-	1	31	13.5	8	20	70	M8	11	95
GN 212.3-24-M8-D	24	40	44.5	2.5	-	16	10	25	96	M8	14	161
GN 212.3-24-M8-E	24	-	-	2.5	37	16	10	25	96	M8	14	159
GN 212.3-24-M10-D	24	40	44.5	2.5	-	16	10	25	96	M10	14	157
GN 212.3-24-M10-E	24	-	-	2.5	37	16	10	25	96	M10	14	155
GN 212.3-28-M10-D	28	48.5	53	4.5	-	19	12	30	110	M10	17	264
GN 212.3-28-M10-E	28	-	-	4.5	44.5	19	12	30	110	M10	17	267
GN 212.3-28-M12-D	28	48.5	53	4.5	-	19	12	30	110	M12	17	258
GN 212.3-28-M12-E	28	-	-	4.5	44.5	19	12	30	110	M12	17	261
GN 212.3-33-M12-D	33	55	60.5	6	-	23	12	32	124	M12	23	381
GN 212.3-33-M12-E	33	-	-	6	51.5	23	12	32	124	M12	23	389
GN 212.3-33-M14-D	33	55	60.5	6	-	23	12	32	124	M14	23	373
GN 212.3-33-M14-E	33	-	-	6	51.5	23	12	32	124	M14	23	381
GN 212.3-33-M16-D	33	55	60.5	6	-	23	12	32	124	M16	23	364
GN 212.3-33-M16-E	33	-	-	6	51.5	23	12	32	124	M16	23	372
GN 212.3-40-M16-D	40	68	73.5	6	-	28	14	35	138	M16	36	638
GN 212.3-40-M16-E	40	-	-	6	64	28	14	35	138	M16	36	634
GN 212.3-40-M20-D	40	68	73.5	6	-	28	14	35	138	M20	36	608
GN 212.3-40-M20-E	40	-	-	6	64	28	14	35	138	M20	36	604



STANDARD MACHINE ELEMENTS WORLDWIDE