

# GN 200-NI

Indexing mechanisms with stop and positioning device

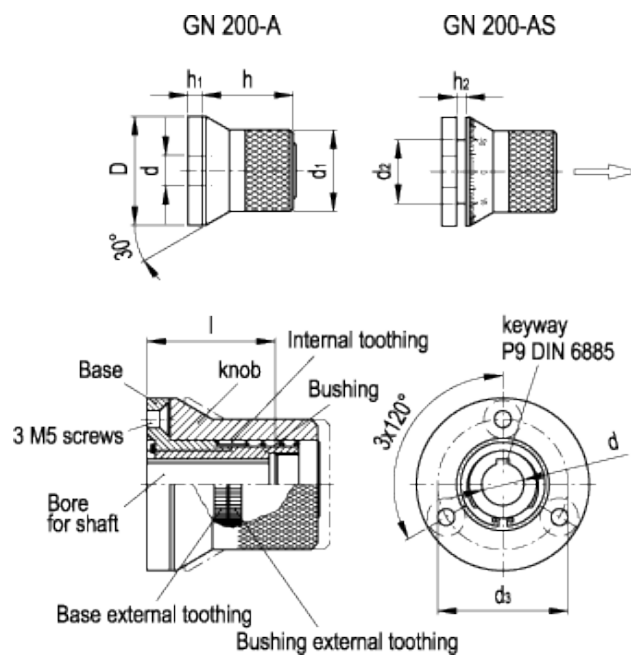

INOX  
Stainless Steel



## technical informations

### Knob

- Execution A: AISI 303 stainless steel, knurled finish.
- Execution AS: matte chrome-plated steel external body with laser-engraved precision flange (scale 0 ...50, 60 [graduations](#)).

### Base

AISI 303 stainless steel. Assembly by means of three holes for M5 countersunk head screws.

### Assembly

AISI 303 stainless steel bushing. H7 reamed hole and keyway in compliance with [DIN 6885/1 P9 tolerance](#) for dimension K10 and in compliance with [DIN 6885/2 P9 tolerance](#) for dimension K14. Assembly to the spindle by means of a keyway or a transversal pin.

## Features and instructions

The knob encloses a small mechanism which allows small rotation movements ( $6^\circ$  or multiples) and the resulting movement and positioning of machine parts.

In rest position, the internal tothing of the knob (60 teeth) is connected simultaneously to the external tothing of the base (fixed) and to the tothing of the bushing (attached to the spindle).

To move the spindle, the knob must be disengaged from the base tothing by pulling or lifting it, applying a force against the spring in the direction of the axis. The external tothing keeps the connection between the knob and the spindle during rotation.

60 teeth provide 2, 3, 4, 5, 6, 10, 12, 15, 20 and 30 precise divisions.

If high torque is required to turn the spindle, problems may arise when engaging and releasing the tothing due to the limited clearance of the walls or the friction of the teeth. In this case, it is recommended to use [GN 215](#) indexing levers.

## Types of mounting

GN 200-NI indexing mechanisms with stop and positioning device can be built also to perform a spindle rotation and lock of it in a given number of positions. For this purpose, a projecting pin inserted into the base allows the tothing to be re-engaged only when the pin is in contact with the corresponding holes in the knob.

The hole can also be drilled with a certain clearance since the main function of the pin is to stop the movement, while the lock is provided by the tothing engagement.

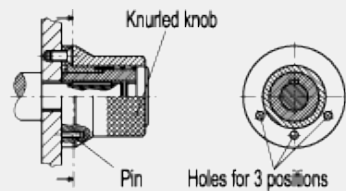

### Assembly example

The shaft is connected to the bushing by means of a keyway. The mechanism is stopped in one of the 3 positions when the pin fits one of the 3 holes in the knob.

## Applications

AISI 303 stainless steel, thanks to its high resistance to corrosion, allows the application of these indexing mechanisms on machines and equipment in those sectors where laws or particular hygienic, climatic and environmental factors make it mandatory to use corrosion resistant materials.

Standard Elements	Main dimensions							Mounting hole		Weight
	Description	D	h	h <sub>1</sub>	h <sub>2</sub>	d <sub>1</sub>	d <sub>2</sub>	d <sub>3</sub>	d <sub>H7</sub>	
GN 200-44-K10-A-NI	44	37	6	4	33	23	33	10	31	309
GN 200-44-K10-AS-NI	44	37	6	4	33	23	33	10	31	309
GN 200-44-K12-A-NI	44	37	6	4	33	23	33	12	31	300
GN 200-44-K12-AS-NI	44	37	6	4	33	23	33	12	31	300
GN 200-52-K12-A-NI	52	37.5	6	4	42	31.5	41.8	12	31.5	478
GN 200-52-K12-AS-NI	52	37.5	6	4	42	31.5	41.8	12	31.5	478
GN 200-52-K14-A-NI	52	37.5	6	4	42	31.5	41.8	14	31.5	467
GN 200-52-K14-AS-NI	52	37.5	6	4	42	31.5	41.8	14	31.5	467
GN 200-52-K16-A-NI	52	37.5	6	4	42	31.5	41.8	16	31.5	455
GN 200-52-K16-AS-NI	52	37.5	6	4	42	31.5	41.8	16	31.5	455



ELESA and GANTER models all rights reserved in accordance with the law. Always mention the source when reproducing our drawings.