

Stainless Steel-Levelling feet

Hygienic Design, with and without mounting holes

SPECIFICATION

Types

- Type **A**: without mounting holes
- Type **B**: with mounting holes

Spindle, adjustable sleeve, foot plate

- Stainless Steel AISI 304
- turned

Seals, blue, FDA compliant

Sealing ring
NBR, hardness 70 ±5 Shore A

Wiper
TPU, hardness 95 ±5 Shore A

Joint sealing ring
H-NBR, hardness 85 ±5 Shore A

Bottom seal
Silicone, hardness 85 ±5 Shore A

INFORMATION

GN 20 Stainless Steel-Levelling feet are certified according to 3-A Sanitary Standards, Inc. guidelines and are intended for use in hygienic areas. In addition, the version with mounting holes (type B) is certified according to EHEDG guidelines.

The bottom seal protects the area beneath the foot plate from dirt. For this, the foot must be screwed on using the mounting holes and compressed accordingly. Hygienic fastenings and the correct position of the mounting holes are essential. The sealing ring above the adjustment sleeve enables fastening without dead space. Due to the wiper or the ball seal, the moving components are sealed against the environment.

The high quality finish prevents adherence of dirt and facilitates cleaning.

The values listed in the table for static load capacity refer to a purely vertical load in relation to the leveling foot. Under normal operating conditions bending loads or angular loads are not uncommon and result in a reduction of load capacity, which must be taken into consideration.

TECHNICAL INFORMATION

- Stainless Steel characteristics (see page A26)
- Elastomer characteristics (see page A32)



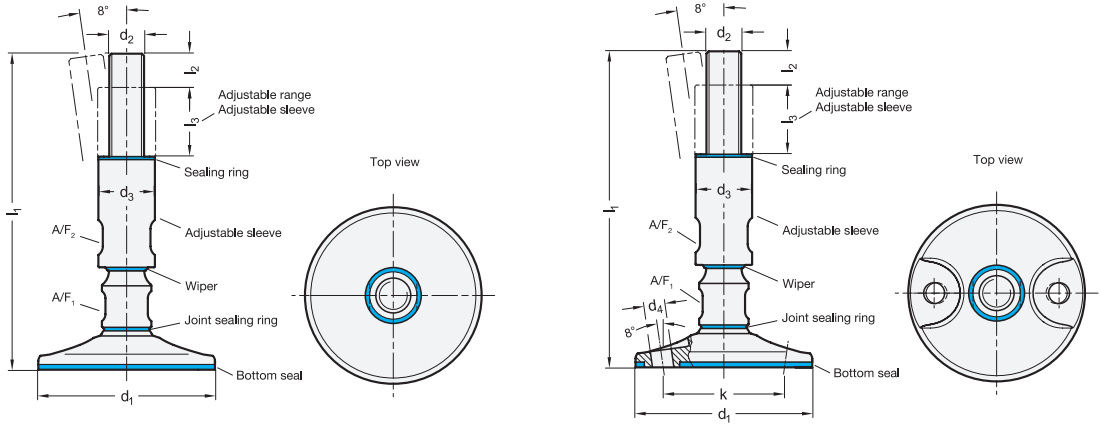

GN 20-A

STAINLESS STEEL

Description	d1	d2	l1	d3	l2	l3	A/F ₁	A/F ₂	Static load in kN	
GN 20-60-M12-175-A	60	M 12	175	25	14	35	17	21	16	581
GN 20-60-M12-225-A	60	M 12	225	25	14	35	17	21	16	732
GN 20-60-M16-175-A	60	M 16	175	28	19	35	18	22	30	680
GN 20-60-M16-225-A	60	M 16	225	28	19	35	18	22	30	830
GN 20-80-M12-175-A	80	M 12	175	25	14	35	17	21	16	890
GN 20-80-M12-225-A	80	M 12	225	25	14	35	17	21	16	932
GN 20-80-M16-175-A	80	M 16	175	28	19	35	18	22	30	904
GN 20-80-M16-225-A	80	M 16	225	28	19	35	18	22	30	983
GN 20-80-M20-185-A	80	M 20	185	32	24	35	24	27	47	1115
GN 20-80-M20-235-A	80	M 20	235	32	24	35	24	27	47	1243
GN 20-80-M24-185-A	80	M 24	185	36	29	35	24	30	67	1284
GN 20-80-M24-235-A	80	M 24	235	36	29	35	24	30	67	1458
GN 20-100-M16-175-A	100	M 16	175	28	19	35	18	22	30	1171
GN 20-100-M16-225-A	100	M 16	225	28	19	35	18	22	30	1252
GN 20-100-M20-185-A	100	M 20	185	32	24	35	24	27	47	1385
GN 20-100-M20-235-A	100	M 20	235	32	24	35	24	27	47	1513
GN 20-100-M24-185-A	100	M 24	185	36	29	35	24	30	67	1546
GN 20-100-M24-235-A	100	M 24	235	36	29	35	24	30	67	1726
GN 20-120-M16-175-A	120	M 16	175	28	19	35	18	22	30	1465
GN 20-120-M16-225-A	120	M 16	225	28	19	35	18	22	30	1549
GN 20-120-M20-185-A	120	M 20	185	32	24	35	24	27	47	1691
GN 20-120-M20-235-A	120	M 20	235	32	24	35	24	27	47	1818
GN 20-120-M24-185-A	120	M 24	185	36	29	35	24	30	67	1853
GN 20-120-M24-235-A	120	M 24	235	36	29	35	24	30	67	2031

GN 20-B

STAINLESS STEEL

Description	d1	d2	l1	d3	d4	l2	l3	k	A/F ₁	A/F ₂	Static load in kN	
GN 20-80-M12-175-B	80	M 12	175	25	9.5	14	35	55.5	17	21	16	842
GN 20-80-M12-225-B	80	M 12	225	25	9.5	14	35	55.5	17	21	16	892
GN 20-80-M16-175-B	80	M 16	175	28	12	19	35	55.5	18	22	30	943
GN 20-80-M20-185-B	80	M 20	185	32	12	24	35	55.5	24	27	47	1149
GN 20-80-M20-235-B	80	M 20	235	32	12	24	35	55.5	24	27	47	1192
GN 20-80-M24-185-B	80	M 24	185	36	12	29	35	55.5	24	30	67	1349
GN 20-80-M24-235-B	80	M 24	235	36	12	29	35	55.5	24	30	67	1491
GN 20-100-M16-175-B	100	M 16	175	28	12	19	35	69	18	22	30	1113
GN 20-100-M16-225-B	100	M 16	225	28	12	19	35	69	18	22	30	1193
GN 20-100-M20-185-B	100	M 20	185	32	12	24	35	69	24	27	47	1325
GN 20-100-M20-235-B	100	M 20	235	32	12	24	35	69	24	27	47	1455
GN 20-100-M24-185-B	100	M 24	185	36	12	29	35	69	24	30	67	1487
GN 20-100-M24-235-B	100	M 24	235	36	12	29	35	69	24	30	67	1668
GN 20-120-M16-175-B	120	M 16	175	28	12	19	35	89	18	22	30	1426
GN 20-120-M16-225-B	120	M 16	225	28	12	19	35	89	18	22	30	1508
GN 20-120-M20-185-B	120	M 20	185	32	12	24	35	89	24	27	47	1641
GN 20-120-M20-235-B	120	M 20	235	32	12	24	35	89	24	27	47	1765
GN 20-120-M24-185-B	120	M 24	185	36	12	29	35	89	24	30	67	1805
GN 20-120-M24-235-B	120	M 24	235	36	12	29	35	89	24	30	67	1980