

## Angle Connector Clamps

### Aluminum

#### SPECIFICATION

##### Identification No.

No. **2**: With 3 stainless steel socket cap screws DIN 912

Aluminum

- Powder coated  
Black, RAL 9005, textured finish **SW**
- Plain, matte shot-blasted **BL**

Socket cap screws DIN 912

Stainless steel AISI 304

Hex nuts DIN 985

Stainless steel AISI 304

Self-locking via polyamide ring

Grub screws DIN 914

Stainless steel AISI 304



#### INFORMATION

The clamping bores of angle connector clamps GN 198 are designed for construction tubes GN 990 (see page 1902) or DIN 2391, DIN 2395 and DIN 2462.

At the screw locations **z**, the socket cap screws reduce the bore cross-section for clamping.

For clamping without tools, the socket cap screws can be replaced by the adjustable hand levers GN 911 (see page 1874) listed in the table as accessories.

#### ACCESSORY

- Adjustable Hand Levers GN 911 (see page 1874)

#### TECHNICAL INFORMATION

- Stainless Steel Characteristics (see page A26)

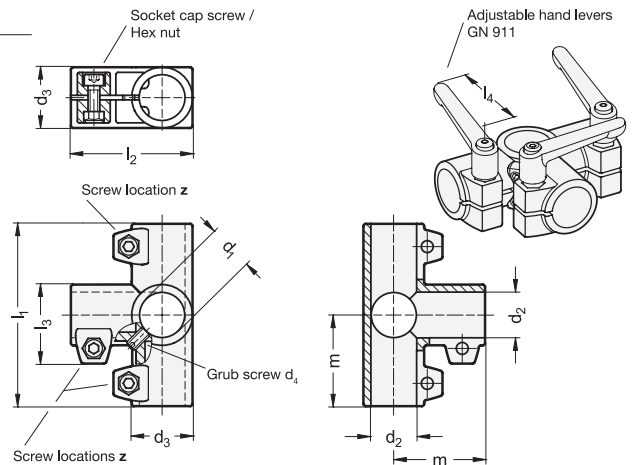

\* Complete with colour index of the Angle Connector Clamps (SW or BL)

	<b>SW</b>	<b>BL</b>
RAL9005	Black	Plain

#### GN 198

Description	d1	d2	d3	d4	l1	l2	l3	m	z Screw locations	Accessory Recom. hand lever GN 911 for z l4	
GN 198-B20-B20-2-*	B 20	B 20	40	M 8	120	80	52	60	M8-25	-	434
GN 198-B25-B25-2-*	B 25	B 25	40	M 8	120	80	52	60	M8-25	78	355
GN 198-B30-B30-2-*	B 30	B 30	40	M 8	120	80	52	60	M8-25	63   78	263
GN 198-B40-B40-2-*	B 40	B 40	65	M 10	206	135.5	77.5	103	M10-50	-	1603
GN 198-B42-B42-2-*	B 42	B 42	65	M 10	206	135.5	77.5	103	M10-50	-	1504
GN 198-B45-B45-2-*	B 45	B 45	65	M 10	206	135.5	77.5	103	M10-50	92	1351
GN 198-B48-B48-2-*	B 48	B 48	65	M 10	206	135.5	77.5	103	M10-50	78   92	1189
GN 198-B50-B50-2-*	B 50	B 50	65	M 10	206	135.5	77.5	103	M10-50	78   92	1078

Weight SW