

Stainless Steel- Serrated locking plates

for welding

SPECIFICATION

Types

- Type **A**: with pass-through hole, without bushing
- Type **B**: with threaded bushing
- Type **C**: with threaded bushing and centring step

Stainless Steel precision casting **NI**

AISI CF-8

Threaded bushing
Stainless Steel AISI 304

Thrust spring
Stainless Steel AISI 301



INFORMATION

With the aid of Stainless Steel-Serrated locking plates GN 188, standard components can be interlocked and firmly attached in defined angular increments. They are joined by welding.

The tothing is positioned exactly on the alignment holes d_4 , which guarantees a parallel or right-angled arrangement.

The thrust spring is placed between the toothed discs during assembly and ensures that the toothed discs separate properly when loosening. The scope of delivery includes two serrated locking plates, one thrust spring and, depending on the version, a threaded bushing.

TECHNICAL INFORMATION

- Stainless Steel characteristics (see page A26)

APPLICATION EXAMPLE

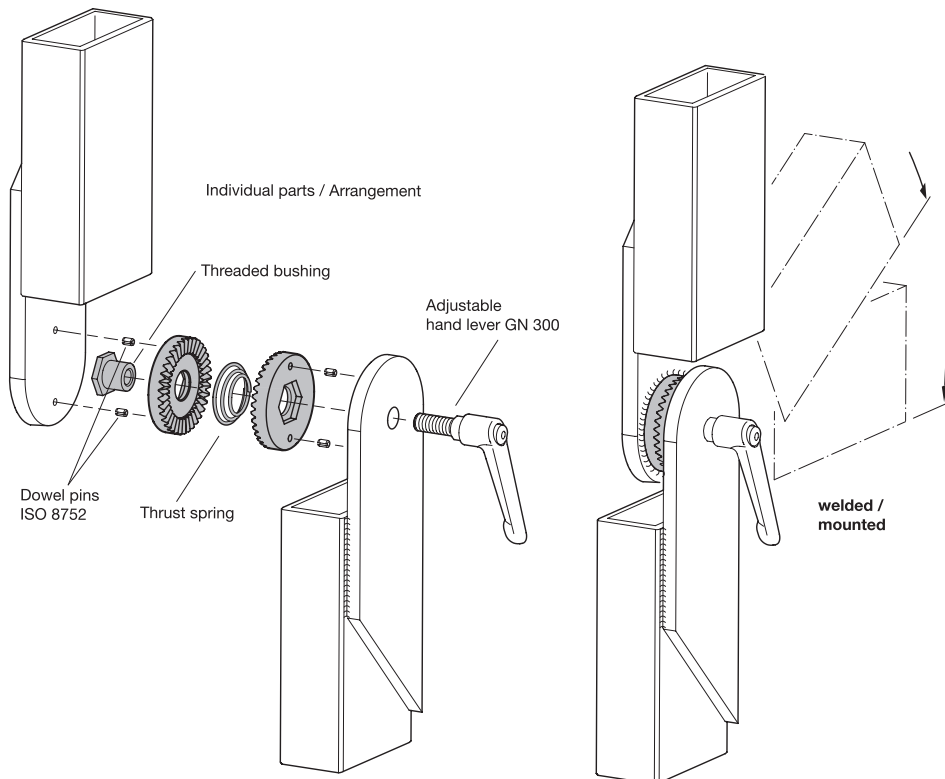

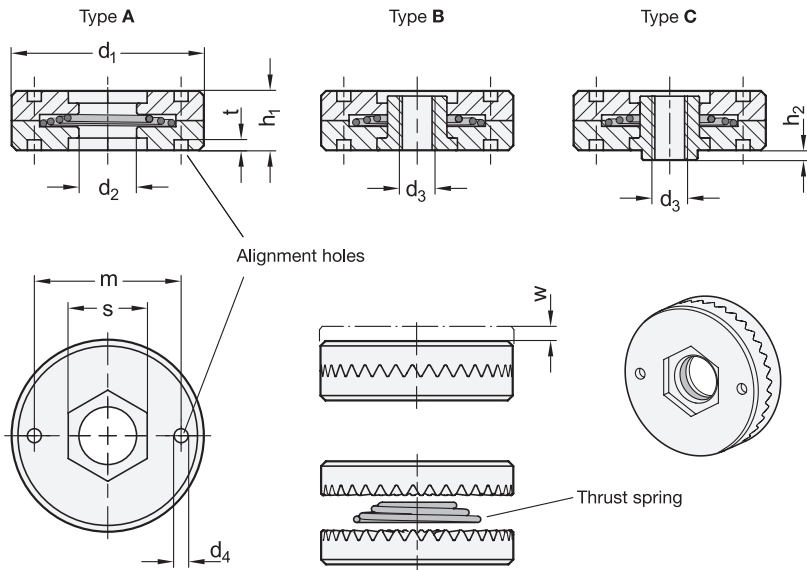

GN 188

STAINLESS STEEL

Description	d1	z	d2	d3	d4	h1	h2	m	s	t	w min.	⚖
GN 188-35-24-A-NI	35	24	B 12	-	3	12	-	26	17	2.5	2.5	1
GN 188-35-36-A-NI	35	36	B 12	-	3	12	-	26	17	2.5	2.5	1
GN 188-55-24-A-NI	55	24	B 16	-	4	17	-	42	22	3	4	4
GN 188-55-36-A-NI	55	36	B 16	-	4	17	-	42	22	3	4	4
GN 188-75-24-A-NI	75	24	B 20	-	5	22	-	60	27	4	5	7
GN 188-75-36-A-NI	75	36	B 20	-	5	22	-	60	27	4	5	7
GN 188-35-24-B-NI	35	24	-	M 8	3	12	-	26	17	2.5	2.5	10
GN 188-35-36-B-NI	35	36	-	M 8	3	12	-	26	17	2.5	2.5	10
GN 188-55-24-B-NI	55	24	-	M 10	4	17	-	42	22	3	4	26
GN 188-55-36-B-NI	55	36	-	M 10	4	17	-	42	22	3	4	26
GN 188-75-24-B-NI	75	24	-	M 12	5	22	-	60	27	4	5	54
GN 188-75-36-B-NI	75	36	-	M 12	5	22	-	60	27	4	5	54
GN 188-35-24-C-NI	35	24	-	M 8	3	12	1.7	26	17	2.5	2.5	11
GN 188-35-36-C-NI	35	36	-	M 8	3	12	1.7	26	17	2.5	2.5	11
GN 188-55-24-C-NI	55	24	-	M 10	4	17	2.8	42	22	3	4	59
GN 188-55-36-C-NI	55	36	-	M 10	4	17	2.8	42	22	3	4	59
GN 188-75-24-C-NI	75	24	-	M 12	5	22	4.7	60	27	4	5	62
GN 188-75-36-C-NI	75	36	-	M 12	5	22	4.7	60	27	4	5	62



Machine elements