

## Flanged Base Plate Connector Clamps

Aluminum, Split Assembly

### SPECIFICATION

#### Identification no.

No. **2**: With 2 stainless steel socket cap screws DIN 912

Aluminum

- Powder coated  
Black, RAL 9005, textured finish **SW**
- Plain finish, matte shot-blasted **BL**

Socket cap screws DIN 912

Stainless steel AISI 304

Hex nuts DIN 985

Stainless steel AISI 304

Self-locking via polyamide ring

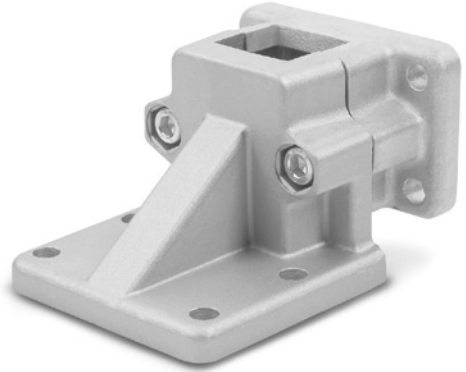

### INFORMATION

The clamping bore of flanged base plate connector clamps GN 171 is not machined and designed for construction tubes GN 990 (see page 1902) or DIN 2391, DIN 2395 and DIN 2462.

The square designs are also suitable for use with **profile systems**.

At the screw locations **z** the socket cap screws reduce the bore cross-section for clamping.

For clamping without tools, the socket cap screws can be replaced by the adjustable hand levers GN 911 (see page 1874) listed in the table as accessories.

### ACCESSORY

- Construction Tubes GN 990 (see page 1902)
- Adjustable Hand Levers GN 911 (see page 1874)

### TECHNICAL INFORMATION

- Stainless Steel Characteristics (see page A26)

\* Complete with

**SW** RAL9005 Plain **BL**

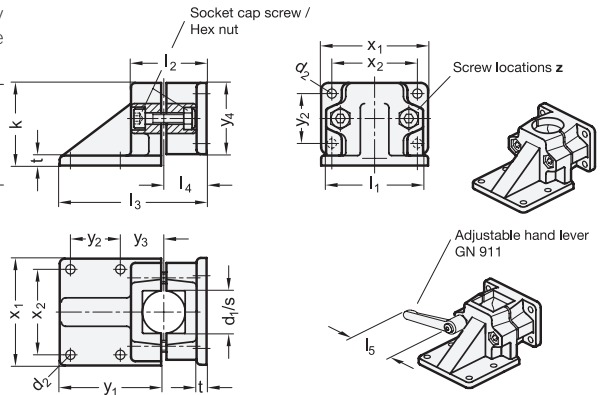

### GN 171-B

Description	d1 Bore	d2	k Clamping length	l1	l2	l3	l4	t	x1	x2	y1	y2	y3	y4	z Screw locations	Accessory Recom. hand lever GN 911 for z l5	⚖️
GN 171-B20-2-*	B 20	7	58	69	53	103	30	7	75	60	72	35	30	50	M8-40	63   78	344
GN 171-B25-2-*	B 25	7	58	69	53	103	30	7	75	60	72	35	30	50	M8-40	63   78	337
GN 171-B30-2-*	B 30	7	58	69	53	103	30	7	75	60	72	35	30	50	M8-40	63   78	330
GN 171-B40-2-*	B 40	11	91	98	82	156	46.5	14	115	90	108	50	45	76	M10-65	78   92	995
GN 171-B42-2-*	B 42	11	91	98	82	156	46.5	14	115	90	108	50	45	76	M10-65	78   92	982
GN 171-B45-2-*	B 45	11	91	98	82	156	46.5	14	115	90	108	50	45	76	M10-65	78   92	973
GN 171-B48-2-*	B 48	11	91	98	82	156	46.5	14	115	90	108	50	45	76	M10-65	78   92	968
GN 171-B50-2-*	B 50	11	91	98	82	156	46.5	14	115	90	108	50	45	76	M10-65	78   92	959
GN 171-B60-2-*	B 60	11	100	108.5	97	186	56	14	125	100	128	52	65.5	90	M10-80	-	942

### GN 171-S

Description	S Square	d2	k Clamping length	l1	l2	l3	l4	t	x1	x2	y1	y2	y3	y4	z Screw locations	Accessory Recom. hand lever GN 911 for z l5	⚖️
GN 171-V20-2-*	V 20	7	58	69	53	103	30	7	75	60	72	35	30	50	M8-40	63   78	343
GN 171-V25-2-*	V 25	7	58	69	53	103	30	7	75	60	72	35	30	50	M8-40	63   78	326
GN 171-V30-2-*	V 30	7	58	69	53	103	30	7	75	60	72	35	30	50	M8-40	63   78	316
GN 171-V40-2-*	V 40	11	91	98	82	156	46.5	14	115	90	108	50	45	76	M10-65	78   92	981
GN 171-V45-2-*	V 45	11	91	98	82	156	46.5	14	115	90	108	50	45	76	M10-65	78   92	958
GN 171-V50-2-*	V 50	11	91	98	82	156	46.5	14	115	90	108	50	45	76	M10-65	78   92	918
GN 171-V60-2-*	V 60	11	100	108.5	97	186	56	14	125	100	128	52	65.5	90	M10-80	-	864

Weight SW