

Wide Base Plate Connector Clamps

SPECIFICATION

Identification No.

No. **2**: With 2 stainless steel socket cap screws DIN 912

Aluminum

- Powder coated
Black, RAL 9005, textured finish **SW**
- Plain, matte shot-blasted **BL**

Socket cap screws DIN 912
Stainless Steel AISI 304

Hex nuts DIN 985
Stainless Steel AISI 304
Self-locking via polyamide ring

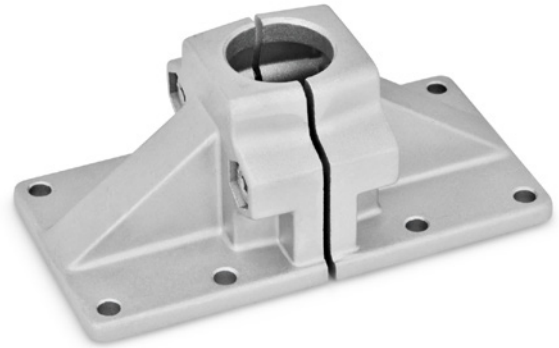

INFORMATION

The clamping bore of wide base plate connector clamps GN 167 is not machined and designed for construction tubes GN 990 (see page 1902) or DIN 2391, DIN 2395 and DIN 2462.

The versions with square bores are also suitable for use with **profile systems**.

At the screw locations **z**, the socket cap screws reduce the bore cross-section for clamping.

For clamping without tools, the socket cap screws can be replaced by the adjustable hand levers GN 911 (see page 1874) listed in the table as accessories.

ACCESSORY

- Adjustable Hand Levers GN 911 (see page 1874)

TECHNICAL INFORMATION

- Stainless Steel Characteristics (see page A26)

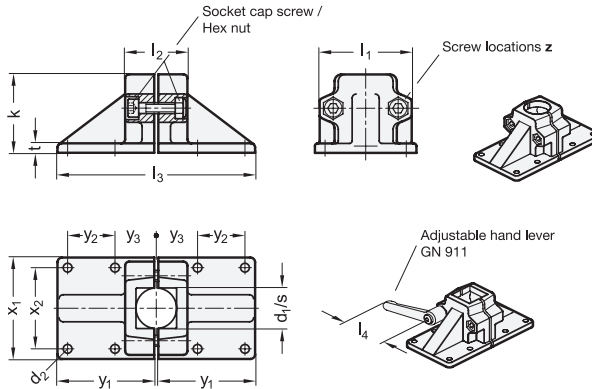

* Complete with
SW BL
RAL9005 Plain

GN 167-B

| Description | d1 Bore | d2 | k Clamping length | l1 | l2 | l3 | t | x1 | x2 | y1 | y2 | y3 | z Screw locations | Accessory Recom. hand lever GN 911 for z l4 | ⚖ |
|----------------|------------|----|-------------------------|----|----|-----|----|-----|----|-----|----|----|-------------------------|---|------|
| GN 167-B20-2-* | B 20 | 7 | 58 | 69 | 46 | 146 | 7 | 75 | 60 | 72 | 35 | 30 | M8-35 | 63 78 | 394 |
| GN 167-B25-2-* | B 25 | 7 | 58 | 69 | 46 | 146 | 7 | 75 | 60 | 72 | 35 | 30 | M8-35 | 63 78 | 388 |
| GN 167-B30-2-* | B 30 | 7 | 58 | 69 | 46 | 146 | 7 | 75 | 60 | 72 | 35 | 30 | M8-35 | 63 78 | 384 |
| GN 167-B40-2-* | B 40 | 11 | 91 | 98 | 70 | 219 | 14 | 115 | 90 | 108 | 50 | 45 | M10-60 | 78 92 | 1222 |
| GN 167-B42-2-* | B 42 | 11 | 91 | 98 | 70 | 219 | 14 | 115 | 90 | 108 | 50 | 45 | M10-60 | 78 92 | 1214 |
| GN 167-B45-2-* | B 45 | 11 | 91 | 98 | 70 | 219 | 14 | 115 | 90 | 108 | 50 | 45 | M10-60 | 78 92 | 1194 |
| GN 167-B48-2-* | B 48 | 11 | 91 | 98 | 70 | 219 | 14 | 115 | 90 | 108 | 50 | 45 | M10-60 | 78 92 | 1172 |
| GN 167-B50-2-* | B 50 | 11 | 91 | 98 | 70 | 219 | 14 | 115 | 90 | 108 | 50 | 45 | M10-60 | 78 92 | 1154 |

GN 167-S

| Description | s | d2 | k Clamping length | l1 | l2 | l3 | t | x1 | x2 | y1 | y2 | y3 | z Screw locations | Accessory Recom. hand lever GN 911 for z l4 | ⚖ |
|----------------|------|----|-------------------------|----|----|-----|----|-----|----|-----|----|----|-------------------------|---|------|
| GN 167-V20-2-* | V 20 | 7 | 58 | 69 | 46 | 146 | 7 | 75 | 60 | 72 | 35 | 30 | M8-35 | 63 78 | 398 |
| GN 167-V25-2-* | V 25 | 7 | 58 | 69 | 46 | 146 | 7 | 75 | 60 | 72 | 35 | 30 | M8-35 | 63 78 | 374 |
| GN 167-V30-2-* | V 30 | 7 | 58 | 69 | 46 | 146 | 7 | 75 | 60 | 72 | 35 | 30 | M8-35 | 63 78 | 368 |
| GN 167-V40-2-* | V 40 | 11 | 91 | 98 | 70 | 219 | 14 | 115 | 90 | 108 | 50 | 45 | M10-60 | 78 92 | 1260 |
| GN 167-V45-2-* | V 45 | 11 | 91 | 98 | 70 | 219 | 14 | 115 | 90 | 108 | 50 | 45 | M10-60 | 78 92 | 1148 |
| GN 167-V50-2-* | V 50 | 11 | 91 | 98 | 70 | 219 | 14 | 115 | 90 | 108 | 50 | 45 | M10-60 | 78 92 | 1048 |

Weight SW