



Screws

Stainless Steel, Hygienic Design

SPECIFICATION

Stainless steel AISI 316L

- Matte finish ($R_a < 0.8 \mu\text{m}$) **MT**
- Polished finish ($R_a < 0.8 \mu\text{m}$) **PL**

Sealing ring

- H-NBR **H**
Temperature resistant $-25 \text{ }^\circ\text{C}$ to $+150 \text{ }^\circ\text{C}$
- EPDM **E**
Temperature resistant $-40 \text{ }^\circ\text{C}$ to $+120 \text{ }^\circ\text{C}$
- Blue
- Hardness 85 ± 5 Shore A
- FDA compliant



INFORMATION

Screws GN 1581 with low-profile head are certified according to EHEDG guidelines and are therefore ideal for use in hygienic areas. The sealed mounting surface enables components to be mounted without dead spaces. The high quality finish as well as the large corner radii and closed surfaces prevent adherence of dirt and facilitate cleaning.

ACCESSORY

- Sealing Rings GN 7600 (see page)

ON REQUEST

- with FKM sealing ring (Fluorine rubber) **F**

TECHNICAL INFORMATION

- Plastic Characteristics (see page A2)
- Stainless Steel Characteristics (see page A26)

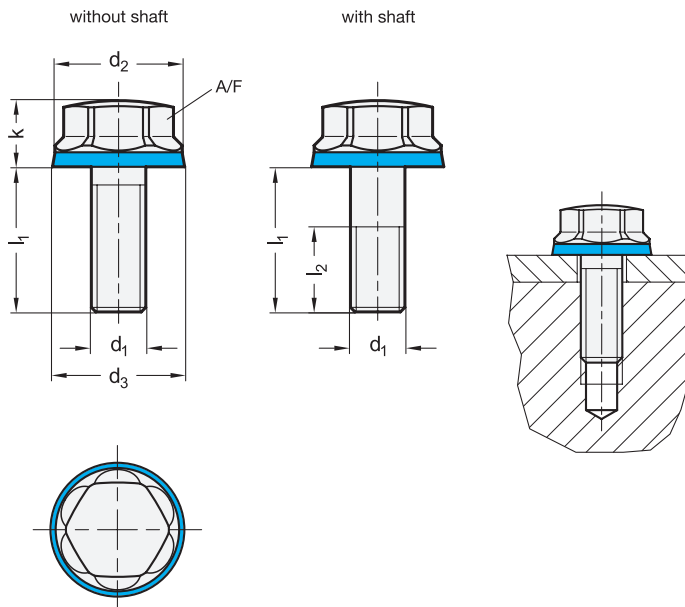

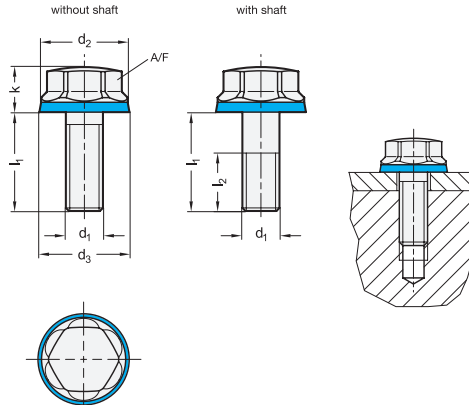

GN 1581-H

STAINLESS STEEL

Description	d1	l1 without shaft	l1 with shaft	d2	d3	k	l2	A/F	Δ
GN 1581-M4-8-MT-H	M4	8	-	10	10.8	6.5	-	7	3
GN 1581-M4-8-PL-H	M4	8	-	10	10.8	6.5	-	7	3
GN 1581-M4-10-MT-H	M4	10	-	10	10.8	6.5	-	7	3
GN 1581-M4-10-PL-H	M4	10	-	10	10.8	6.5	-	7	3
GN 1581-M4-12-MT-H	M4	12	-	10	10.8	6.5	-	7	3
GN 1581-M4-12-PL-H	M4	12	-	10	10.8	6.5	-	7	3
GN 1581-M4-16-MT-H	M4	-	16	10	10.8	6.5	-	7	4
GN 1581-M4-16-PL-H	M4	-	16	10	10.8	6.5	-	7	4
GN 1581-M4-20-MT-H	M4	-	20	10	10.8	6.5	14	7	4
GN 1581-M4-20-PL-H	M4	-	20	10	10.8	6.5	14	7	4
GN 1581-M4-25-MT-H	M4	-	25	10	10.8	6.5	-	7	5
GN 1581-M4-25-PL-H	M4	-	25	10	10.8	6.5	-	7	5
GN 1581-M4-30-MT-H	M4	-	30	10	10.8	6.5	14	7	5
GN 1581-M4-30-PL-H	M4	-	30	10	10.8	6.5	14	7	5
GN 1581-M5-10-MT-H	M5	10	-	11	11.8	7	-	8	6
GN 1581-M5-10-PL-H	M5	10	-	11	11.8	7	-	8	6
GN 1581-M5-16-MT-H	M5	16	-	11	11.8	7	-	8	6
GN 1581-M5-16-PL-H	M5	16	-	11	11.8	7	-	8	6
GN 1581-M5-20-MT-H	M5	-	20	11	11.8	7	16	8	6
GN 1581-M5-20-PL-H	M5	-	20	11	11.8	7	16	8	6
GN 1581-M5-25-MT-H	M5	-	25	11	11.8	7	-	8	7
GN 1581-M5-25-PL-H	M5	-	25	11	11.8	7	-	8	7
GN 1581-M5-30-MT-H	M5	-	30	11	11.8	7	16	8	10
GN 1581-M5-30-PL-H	M5	-	30	11	11.8	7	16	8	10
GN 1581-M5-35-MT-H	M5	-	35	11	11.8	7	-	8	8
GN 1581-M5-35-PL-H	M5	-	35	11	11.8	7	-	8	8
GN 1581-M5-40-MT-H	M5	-	40	11	11.8	7	16	8	9
GN 1581-M5-40-PL-H	M5	-	40	11	11.8	7	16	8	9
GN 1581-M6-12-MT-H	M6	12	-	13	13.8	7.5	-	10	8
GN 1581-M6-12-PL-H	M6	12	-	13	13.8	7.5	-	10	8
GN 1581-M6-16-MT-H	M6	16	-	13	13.8	7.5	-	10	9
GN 1581-M6-16-PL-H	M6	16	-	13	13.8	7.5	-	10	9
GN 1581-M6-20-MT-H	M6	20	-	13	13.8	7.5	-	10	10
GN 1581-M6-20-PL-H	M6	20	-	13	13.8	7.5	-	10	10
GN 1581-M6-25-MT-H	M6	25	-	13	13.8	7.5	-	10	11
GN 1581-M6-25-PL-H	M6	25	-	13	13.8	7.5	-	10	11
GN 1581-M6-30-MT-H	M6	-	30	13	13.8	7.5	18	10	12
GN 1581-M6-30-PL-H	M6	-	30	13	13.8	7.5	18	10	12
GN 1581-M6-35-MT-H	M6	-	35	13	13.8	7.5	-	10	12
GN 1581-M6-35-PL-H	M6	-	35	13	13.8	7.5	-	10	12
GN 1581-M6-40-MT-H	M6	-	40	13	13.8	7.5	18	10	14
GN 1581-M6-40-PL-H	M6	-	40	13	13.8	7.5	18	10	14
GN 1581-M6-50-MT-H	M6	-	50	13	13.8	7.5	18	10	16
GN 1581-M6-50-PL-H	M6	-	50	13	13.8	7.5	18	10	16
GN 1581-M8-16-MT-H	M8	16	-	16	16.8	8.5	-	13	16
GN 1581-M8-16-PL-H	M8	16	-	16	16.8	8.5	-	13	16
GN 1581-M8-20-MT-H	M8	20	-	16	16.8	8.5	-	13	17

GN 1581-H

STAINLESS STEEL

Description	d1	l1 without shaft	l1 with shaft	d2	d3	k	l2	A/F	Δ
GN 1581-M8-20-PL-H	M8	20	-	16	16.8	8.5	-	13	17
GN 1581-M8-25-MT-H	M8	25	-	16	16.8	8.5	-	13	19
GN 1581-M8-25-PL-H	M8	25	-	16	16.8	8.5	-	13	19
GN 1581-M8-30-MT-H	M8	30	-	16	16.8	8.5	-	13	21
GN 1581-M8-30-PL-H	M8	30	-	16	16.8	8.5	-	13	21
GN 1581-M8-40-MT-H	M8	-	40	16	16.8	8.5	22	13	25
GN 1581-M8-40-PL-H	M8	-	40	16	16.8	8.5	22	13	25
GN 1581-M8-50-MT-H	M8	-	50	16	16.8	8.5	22	13	29
GN 1581-M8-50-PL-H	M8	-	50	16	16.8	8.5	22	13	29
GN 1581-M8-60-MT-H	M8	-	60	16	16.8	8.5	22	13	33
GN 1581-M8-60-PL-H	M8	-	60	16	16.8	8.5	22	13	33
GN 1581-M10-20-MT-H	M10	20	-	19	19.8	9.5	-	16	28
GN 1581-M10-20-PL-H	M10	20	-	19	19.8	9.5	-	16	28
GN 1581-M10-25-MT-H	M10	25	-	19	19.8	9.5	-	16	31
GN 1581-M10-25-PL-H	M10	25	-	19	19.8	9.5	-	16	31
GN 1581-M10-30-MT-H	M10	30	-	19	19.8	9.5	-	16	34
GN 1581-M10-30-PL-H	M10	30	-	19	19.8	9.5	-	16	34
GN 1581-M10-40-MT-H	M10	-	40	19	19.8	9.5	26	16	40
GN 1581-M10-40-PL-H	M10	-	40	19	19.8	9.5	26	16	40
GN 1581-M10-50-MT-H	M10	-	50	19	19.8	9.5	26	16	46
GN 1581-M10-50-PL-H	M10	-	50	19	19.8	9.5	26	16	46
GN 1581-M10-60-MT-H	M10	-	60	19	19.8	9.5	26	16	52
GN 1581-M10-60-PL-H	M10	-	60	19	19.8	9.5	26	16	52
GN 1581-M12-25-MT-H	M12	25	-	22	22.8	11	-	18	46
GN 1581-M12-25-PL-H	M12	25	-	22	22.8	11	-	18	46
GN 1581-M12-30-MT-H	M12	30	-	22	22.8	11	-	18	50
GN 1581-M12-30-PL-H	M12	30	-	22	22.8	11	-	18	50
GN 1581-M12-40-MT-H	M12	-	40	22	22.8	11	30	18	59
GN 1581-M12-40-PL-H	M12	-	40	22	22.8	11	30	18	59
GN 1581-M12-50-MT-H	M12	-	50	22	22.8	11	30	18	68
GN 1581-M12-50-PL-H	M12	-	50	22	22.8	11	30	18	68
GN 1581-M12-60-MT-H	M12	-	60	22	22.8	11	30	18	76
GN 1581-M12-60-PL-H	M12	-	60	22	22.8	11	30	18	76
GN 1581-M16-30-MT-H	M16	30	-	28	28.8	13	-	22	90
GN 1581-M16-30-PL-H	M16	30	-	28	28.8	13	-	22	90
GN 1581-M16-40-MT-H	M16	40	-	28	28.8	13	-	22	106
GN 1581-M16-40-PL-H	M16	40	-	28	28.8	13	-	22	106
GN 1581-M16-50-MT-H	M16	-	50	28	28.8	13	38	22	122
GN 1581-M16-50-PL-H	M16	-	50	28	28.8	13	38	22	122
GN 1581-M16-60-MT-H	M16	-	60	28	28.8	13	38	22	137
GN 1581-M16-60-PL-H	M16	-	60	28	28.8	13	38	22	137
GN 1581-M16-70-MT-H	M16	-	70	28	28.8	13	38	22	153
GN 1581-M16-70-PL-H	M16	-	70	28	28.8	13	38	22	153
GN 1581-M20-40-MT-H	M20	40	-	34	34.8	15	-	27	172
GN 1581-M20-40-PL-H	M20	40	-	34	34.8	15	-	27	172
GN 1581-M20-60-MT-H	M20	-	60	34	34.8	15	46	27	221
GN 1581-M20-60-PL-H	M20	-	60	34	34.8	15	46	27	221



Machine Elements

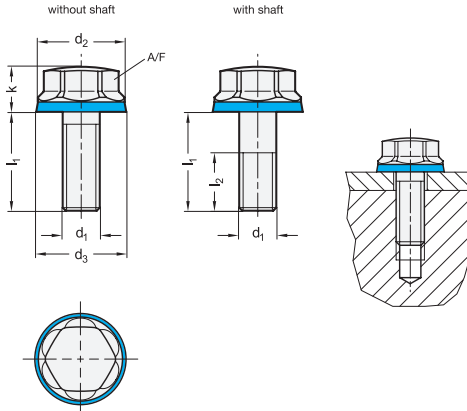

GN 1581-E STAINLESS STEEL

Description	d1	li without shaft	li with shaft	d2	d3	k	l2	A/F	△
GN 1581-M4-8-MT-E	M4	8	-	10	10.8	6.5	-	7	3
GN 1581-M4-8-PL-E	M4	8	-	10	10.8	6.5	-	7	3
GN 1581-M4-10-MT-E	M4	10	-	10	10.8	6.5	-	7	3
GN 1581-M4-10-PL-E	M4	10	-	10	10.8	6.5	-	7	3
GN 1581-M4-12-MT-E	M4	12	-	10	10.8	6.5	-	7	3
GN 1581-M4-12-PL-E	M4	12	-	10	10.8	6.5	-	7	3
GN 1581-M4-16-MT-E	M4	-	16	10	10.8	6.5	-	7	4
GN 1581-M4-16-PL-E	M4	-	16	10	10.8	6.5	-	7	4
GN 1581-M4-20-MT-E	M4	-	20	10	10.8	6.5	14	7	4
GN 1581-M4-20-PL-E	M4	-	20	10	10.8	6.5	14	7	4
GN 1581-M4-25-MT-E	M4	-	25	10	10.8	6.5	-	7	5
GN 1581-M4-25-PL-E	M4	-	25	10	10.8	6.5	-	7	5
GN 1581-M4-30-MT-E	M4	-	30	10	10.8	6.5	14	7	5
GN 1581-M4-30-PL-E	M4	-	30	10	10.8	6.5	14	7	5
GN 1581-M5-10-MT-E	M5	10	-	11	11.8	7	-	8	6
GN 1581-M5-10-PL-E	M5	10	-	11	11.8	7	-	8	6
GN 1581-M5-16-MT-E	M5	16	-	11	11.8	7	-	8	5
GN 1581-M5-16-PL-E	M5	16	-	11	11.8	7	-	8	6
GN 1581-M5-20-MT-E	M5	-	20	11	11.8	7	16	8	6
GN 1581-M5-20-PL-E	M5	-	20	11	11.8	7	16	8	6
GN 1581-M5-25-MT-E	M5	-	25	11	11.8	7	-	8	7
GN 1581-M5-25-PL-E	M5	-	25	11	11.8	7	-	8	7
GN 1581-M5-30-MT-E	M5	-	30	11	11.8	7	16	8	10
GN 1581-M5-30-PL-E	M5	-	30	11	11.8	7	16	8	10
GN 1581-M5-35-MT-E	M5	-	35	11	11.8	7	-	8	8
GN 1581-M5-35-PL-E	M5	-	35	11	11.8	7	-	8	8
GN 1581-M5-40-MT-E	M5	-	40	11	11.8	7	16	8	9
GN 1581-M5-40-PL-E	M5	-	40	11	11.8	7	16	8	9
GN 1581-M6-12-MT-E	M6	12	-	13	13.8	7.5	-	10	8
GN 1581-M6-12-PL-E	M6	12	-	13	13.8	7.5	-	10	8
GN 1581-M6-16-MT-E	M6	16	-	13	13.8	7.5	-	10	9
GN 1581-M6-16-PL-E	M6	16	-	13	13.8	7.5	-	10	9
GN 1581-M6-20-MT-E	M6	20	-	13	13.8	7.5	-	10	10
GN 1581-M6-20-PL-E	M6	20	-	13	13.8	7.5	-	10	10
GN 1581-M6-25-MT-E	M6	25	-	13	13.8	7.5	-	10	11
GN 1581-M6-25-PL-E	M6	25	-	13	13.8	7.5	-	10	11
GN 1581-M6-30-MT-E	M6	-	30	13	13.8	7.5	18	10	12
GN 1581-M6-30-PL-E	M6	-	30	13	13.8	7.5	18	10	12
GN 1581-M6-35-MT-E	M6	-	35	13	13.8	7.5	-	10	12
GN 1581-M6-35-PL-E	M6	-	35	13	13.8	7.5	-	10	12
GN 1581-M6-40-MT-E	M6	-	40	13	13.8	7.5	18	10	14
GN 1581-M6-40-PL-E	M6	-	40	13	13.8	7.5	18	10	14
GN 1581-M6-50-MT-E	M6	-	50	13	13.8	7.5	18	10	16
GN 1581-M6-50-PL-E	M6	-	50	13	13.8	7.5	18	10	16
GN 1581-M8-16-MT-E	M8	16	-	16	16.8	8.5	-	13	16
GN 1581-M8-16-PL-E	M8	16	-	16	16.8	8.5	-	13	16
GN 1581-M8-20-MT-E	M8	20	-	16	16.8	8.5	-	13	17

GN 1581-E STAINLESS STEEL

Description	d1	li without shaft	li with shaft	d2	d3	k	l2	A/F	△
GN 1581-M8-20-PL-E	M8	20	-	16	16.8	8.5	-	13	17
GN 1581-M8-25-MT-E	M8	25	-	16	16.8	8.5	-	13	19
GN 1581-M8-25-PL-E	M8	25	-	16	16.8	8.5	-	13	19
GN 1581-M8-30-MT-E	M8	30	-	16	16.8	8.5	-	13	21
GN 1581-M8-30-PL-E	M8	30	-	16	16.8	8.5	-	13	21
GN 1581-M8-40-MT-E	M8	-	40	16	16.8	8.5	22	13	25
GN 1581-M8-40-PL-E	M8	-	40	16	16.8	8.5	22	13	25
GN 1581-M8-50-MT-E	M8	-	50	16	16.8	8.5	22	13	29
GN 1581-M8-50-PL-E	M8	-	50	16	16.8	8.5	22	13	29
GN 1581-M8-60-MT-E	M8	-	60	16	16.8	8.5	22	13	33
GN 1581-M8-60-PL-E	M8	-	60	16	16.8	8.5	22	13	33
GN 1581-M10-20-MT-E	M10	20	-	19	19.8	9.5	-	16	28
GN 1581-M10-20-PL-E	M10	20	-	19	19.8	9.5	-	16	28
GN 1581-M10-25-MT-E	M10	25	-	19	19.8	9.5	-	16	31
GN 1581-M10-25-PL-E	M10	25	-	19	19.8	9.5	-	16	31
GN 1581-M10-30-MT-E	M10	30	-	19	19.8	9.5	-	16	34
GN 1581-M10-30-PL-E	M10	30	-	19	19.8	9.5	-	16	34
GN 1581-M10-40-MT-E	M10	-	40	19	19.8	9.5	26	16	40
GN 1581-M10-40-PL-E	M10	-	40	19	19.8	9.5	26	16	40
GN 1581-M10-50-MT-E	M10	-	50	19	19.8	9.5	26	16	46
GN 1581-M10-50-PL-E	M10	-	50	19	19.8	9.5	26	16	46
GN 1581-M10-60-MT-E	M10	-	60	19	19.8	9.5	26	16	52
GN 1581-M10-60-PL-E	M10	-	60	19	19.8	9.5	26	16	52
GN 1581-M12-25-MT-E	M12	25	-	22	22.8	11	-	18	46
GN 1581-M12-25-PL-E	M12	25	-	22	22.8	11	-	18	46
GN 1581-M12-30-MT-E	M12	30	-	22	22.8	11	-	18	50
GN 1581-M12-30-PL-E	M12	30	-	22	22.8	11	-	18	50
GN 1581-M12-40-MT-E	M12	-	40	22	22.8	11	30	18	59
GN 1581-M12-40-PL-E	M12	-	40	22	22.8	11	30	18	59
GN 1581-M12-50-MT-E	M12	-	50	22	22.8	11	30	18	68
GN 1581-M12-50-PL-E	M12	-	50	22	22.8	11	30	18	68
GN 1581-M12-60-MT-E	M12	-	60	22	22.8	11	30	18	76
GN 1581-M12-60-PL-E	M12	-	60	22	22.8	11	30	18	76
GN 1581-M16-30-MT-E	M16	30	-	28	28.8	13	-	22	90
GN 1581-M16-30-PL-E	M16	30	-	28	28.8	13	-	22	90
GN 1581-M16-40-MT-E	M16	40	-	28	28.8	13	-	22	106
GN 1581-M16-40-PL-E	M16	40	-	28	28.8	13	-	22	106
GN 1581-M16-50-MT-E	M16	-	50	28	28.8	13	38	22	122
GN 1581-M16-50-PL-E	M16	-	50	28	28.8	13	38	22	122
GN 1581-M16-60-MT-E	M16	-	60	28	28.8	13	38	22	137
GN 1581-M16-60-PL-E	M16	-	60	28	28.8	13	38	22	137
GN 1581-M16-70-MT-E	M16	-	70	28	28.8	13	38	22	153
GN 1581-M16-70-PL-E	M16	-	70	28	28.8	13	38	22	153
GN 1581-M20-40-MT-E	M20	40	-	34	34.8	15	-	27	172
GN 1581-M20-40-PL-E	M20	40	-	34	34.8	15	-	27	172
GN 1581-M20-60-MT-E	M20	-	60	34	34.8	15	46	27	221
GN 1581-M20-60-PL-E	M20	-	60	34	34.8	15	46	27	221



Machine Elements 9