

## Nuts / Screws

**Stainless Steel, Hygienic Design**

### SPECIFICATION

Stainless steel AISI 316L

- Matte finish (Ra < 0.8 µm) **MT**
- Polished finish (Ra < 0.8 µm) **PL**

Sealing ring

- H-NBR **H**  
Temperature resistant -25 °C to +150 °C
- EPDM **E**  
Temperature resistant -40 °C to +120 °C
- Blue
- Hardness 85±5 Shore A
- FDA compliant

### INFORMATION

Nuts / Screws GN 1580 are certified according to EHEDG guidelines and are therefore ideal for use in hygienic areas. The sealed mounting surface enables components to be mounted without dead spaces. The high quality finish as well as the large corner radii and closed surfaces prevent adherence of dirt and facilitate cleaning.

### ACCESSORY

- Sealing Rings GN 7600 (see page )

### ON REQUEST

- with FKM sealing ring (Fluorine rubber) **F**

### TECHNICAL INFORMATION

- Plastic Characteristics (see page A2)
- Stainless Steel Characteristics (see page A26)

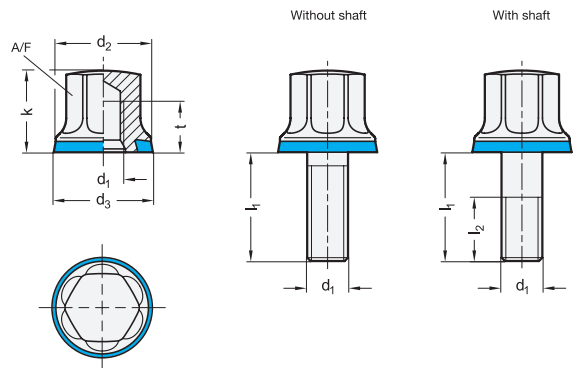

**GN 1580-Nuts STAINLESS STEEL**

Description	d1	d2	d3	k	t min.	A/F	⚖
GN 1580-M4-MT-H	M 4	11	11.8	9.5	6	7	3
GN 1580-M4-PL-H	M 4	11	11.8	9.5	6	7	3
GN 1580-M5-MT-H	M 5	12	12.8	10	6	8	8
GN 1580-M5-PL-H	M 5	12	12.8	10	6	8	8
GN 1580-M6-MT-H	M 6	14	14.8	12	7.5	10	10
GN 1580-M6-PL-H	M 6	14	14.8	12	7.5	10	10
GN 1580-M8-MT-H	M 8	18	18.8	14.5	9.5	13	17
GN 1580-M8-PL-H	M 8	18	18.8	14.5	9.5	13	17
GN 1580-M10-MT-H	M 10	21	21.8	18	12	16	19
GN 1580-M10-PL-H	M 10	21	21.8	18	12	16	19
GN 1580-M12-MT-H	M 12	25	25.8	21	14.5	18	45
GN 1580-M12-PL-H	M 12	25	25.8	21	14.5	18	45
GN 1580-M16-MT-H	M 16	32	32.8	26	17	24	84
GN 1580-M16-PL-H	M 16	32	32.8	26	17	24	84
GN 1580-M20-MT-H	M 20	40	40.8	32	22	30	150
GN 1580-M20-PL-H	M 20	40	40.8	32	22	30	150

**GN 1580-Nuts STAINLESS STEEL**

Description	d1	d2	d3	k	t min.	A/F	⚖
GN 1580-M4-MT-E	M 4	11	11.8	9.5	6	7	3
GN 1580-M4-PL-E	M 4	11	11.8	9.5	6	7	3
GN 1580-M5-MT-E	M 5	12	12.8	10	6	8	4
GN 1580-M5-PL-E	M 5	12	12.8	10	6	8	8
GN 1580-M6-MT-E	M 6	14	14.8	12	7.5	10	10
GN 1580-M6-PL-E	M 6	14	14.8	12	7.5	10	10
GN 1580-M8-MT-E	M 8	18	18.8	14.5	9.5	13	17
GN 1580-M8-PL-E	M 8	18	18.8	14.5	9.5	13	17
GN 1580-M10-MT-E	M 10	21	21.8	18	12	16	19
GN 1580-M10-PL-E	M 10	21	21.8	18	12	16	19
GN 1580-M12-MT-E	M 12	25	25.8	21	14.5	18	45
GN 1580-M12-PL-E	M 12	25	25.8	21	14.5	18	45
GN 1580-M16-MT-E	M 16	32	32.8	26	17	24	84
GN 1580-M16-PL-E	M 16	32	32.8	26	17	24	84
GN 1580-M20-MT-E	M 20	40	40.8	32	22	30	150
GN 1580-M20-PL-E	M 20	40	40.8	32	22	30	150

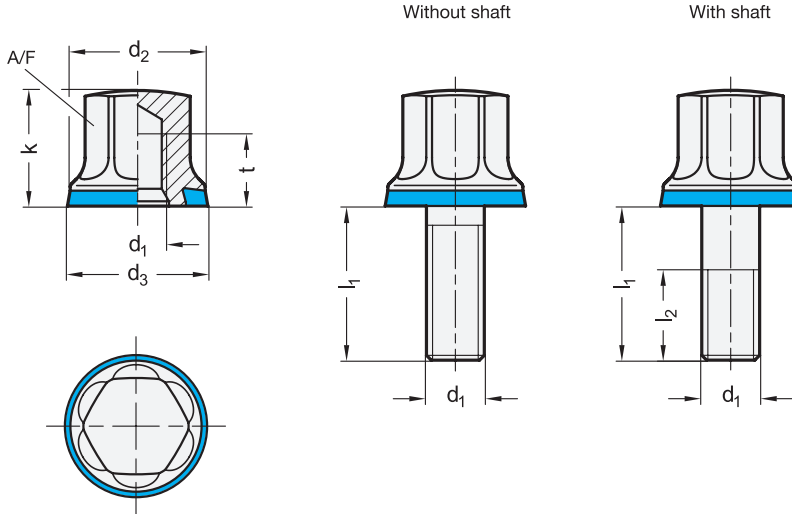

GN 1580-Screws

STAINLESS STEEL

Description	d1	l1 without shaft	l1 with shaft	d2	d3	k	l2	A/F	⚖
GN 1580-M4-8-MT-H	M 4	8	-	11	11.8	9.5	-	7	4
GN 1580-M4-8-PL-H	M 4	8	-	11	11.8	9.5	-	7	5
GN 1580-M4-10-MT-H	M 4	10	-	11	11.8	9.5	14	7	5
GN 1580-M4-10-PL-H	M 4	10	-	11	11.8	9.5	14	7	5
GN 1580-M4-12-MT-H	M 4	12	-	11	11.8	9.5	-	7	5
GN 1580-M4-12-PL-H	M 4	12	-	11	11.8	9.5	-	7	4
GN 1580-M4-16-MT-H	M 4	-	16	11	11.8	-	14	7	5
GN 1580-M4-16-PL-H	M 4	-	16	11	11.8	-	14	7	5
GN 1580-M5-10-MT-H	M 5	10	-	12	12.8	10	-	8	13
GN 1580-M5-10-PL-H	M 5	10	-	12	12.8	10	-	8	13
GN 1580-M5-16-MT-H	M 5	16	-	12	12.8	10	-	8	10
GN 1580-M5-16-PL-H	M 5	16	-	12	12.8	10	-	8	10
GN 1580-M5-20-MT-H	M 5	20	-	12	12.8	10	-	8	11
GN 1580-M5-20-PL-H	M 5	20	-	12	12.8	10	-	8	11
GN 1580-M6-12-MT-H	M 6	12	-	14	14.8	12	-	10	14
GN 1580-M6-12-PL-H	M 6	12	-	14	14.8	12	-	10	14
GN 1580-M6-16-MT-H	M 6	16	-	14	14.8	12	-	10	15
GN 1580-M6-16-PL-H	M 6	16	-	14	14.8	12	-	10	15
GN 1580-M6-20-MT-H	M 6	20	-	14	14.8	12	-	10	13
GN 1580-M6-20-PL-H	M 6	20	-	14	14.8	12	-	10	13
GN 1580-M6-25-MT-H	M 6	25	-	14	14.8	12	-	10	13
GN 1580-M6-25-PL-H	M 6	25	-	14	14.8	12	-	10	13
GN 1580-M6-30-MT-H	M 6	30	-	14	14.8	12	-	10	17
GN 1580-M6-30-PL-H	M 6	30	-	14	14.8	12	-	10	17
GN 1580-M8-16-MT-H	M 8	16	-	18	18.8	14.5	-	13	24
GN 1580-M8-16-PL-H	M 8	16	-	18	18.8	14.5	-	13	24
GN 1580-M8-20-MT-H	M 8	20	-	18	18.8	14.5	-	13	28
GN 1580-M8-20-PL-H	M 8	20	-	18	18.8	14.5	-	13	28
GN 1580-M8-25-MT-H	M 8	25	-	18	18.8	14.5	-	13	28
GN 1580-M8-25-PL-H	M 8	25	-	18	18.8	14.5	-	13	28
GN 1580-M8-30-MT-H	M 8	30	-	18	18.8	14.5	-	13	30
GN 1580-M8-30-PL-H	M 8	30	-	18	18.8	14.5	-	13	30
GN 1580-M8-40-MT-H	M 8	-	40	18	18.8	-	22	13	33
GN 1580-M8-40-PL-H	M 8	-	40	18	18.8	-	22	13	33

GN 1580-Screws

STAINLESS STEEL

Description	d1	l1 without shaft	l1 with shaft	d2	d3	k	l2	A/F	⚖
GN 1580-M10-20-MT-H	M 10	20	-	21	21.8	18	-	16	49
GN 1580-M10-20-PL-H	M 10	20	-	21	21.8	18	-	16	49
GN 1580-M10-25-MT-H	M 10	25	-	21	21.8	18	-	16	51
GN 1580-M10-25-PL-H	M 10	25	-	21	21.8	18	-	16	51
GN 1580-M10-30-MT-H	M 10	30	-	21	21.8	18	-	16	54
GN 1580-M10-30-PL-H	M 10	30	-	21	21.8	18	-	16	54
GN 1580-M10-40-MT-H	M 10	-	40	21	21.8	-	26	16	59
GN 1580-M10-40-PL-H	M 10	-	40	21	21.8	-	26	16	59
GN 1580-M10-50-MT-H	M 10	-	50	21	21.8	-	26	16	64
GN 1580-M10-50-PL-H	M 10	-	50	21	21.8	-	26	16	64
GN 1580-M12-25-PL-H	M 12	25	-	25	25.8	21	-	18	79
GN 1580-M12-25-MT-H	M 12	25	-	25	25.8	21	-	18	79
GN 1580-M12-30-PL-H	M 12	30	-	25	25.8	21	-	18	84
GN 1580-M12-30-MT-H	M 12	30	-	25	25.8	21	-	18	70
GN 1580-M12-40-PL-H	M 12	-	40	25	25.8	-	30	18	93
GN 1580-M12-40-MT-H	M 12	-	40	25	25.8	-	30	18	77
GN 1580-M12-50-PL-H	M 12	-	50	25	25.8	-	30	18	102
GN 1580-M12-50-MT-H	M 12	-	50	25	25.8	-	30	18	102
GN 1580-M12-60-PL-H	M 12	-	60	25	25.8	-	30	18	111
GN 1580-M12-60-MT-H	M 12	-	60	25	25.8	-	30	18	111
GN 1580-M16-30-PL-H	M 16	30	-	32	32.8	26	38	24	157
GN 1580-M16-30-MT-H	M 16	30	-	32	32.8	26	38	24	157
GN 1580-M16-40-PL-H	M 16	40	-	32	32.8	26	38	24	173
GN 1580-M16-40-MT-H	M 16	40	-	32	32.8	26	38	24	173
GN 1580-M16-50-PL-H	M 16	-	50	32	32.8	26	38	24	189
GN 1580-M16-50-MT-H	M 16	-	50	32	32.8	26	38	24	189
GN 1580-M16-60-PL-H	M 16	-	60	32	32.8	26	38	24	205
GN 1580-M16-60-MT-H	M 16	-	60	32	32.8	26	38	24	187
GN 1580-M16-70-PL-H	M 16	-	70	32	32.8	26	38	24	221
GN 1580-M16-70-MT-H	M 16	-	70	32	32.8	26	38	24	203
GN 1580-M20-40-MT-H	M 20	40	-	40	40.8	32	46	30	296
GN 1580-M20-40-PL-H	M 20	40	-	40	40.8	32	46	30	296
GN 1580-M20-60-MT-H	M 20	-	60	40	40.8	32	46	30	346
GN 1580-M20-60-PL-H	M 20	-	60	40	40.8	32	46	30	346



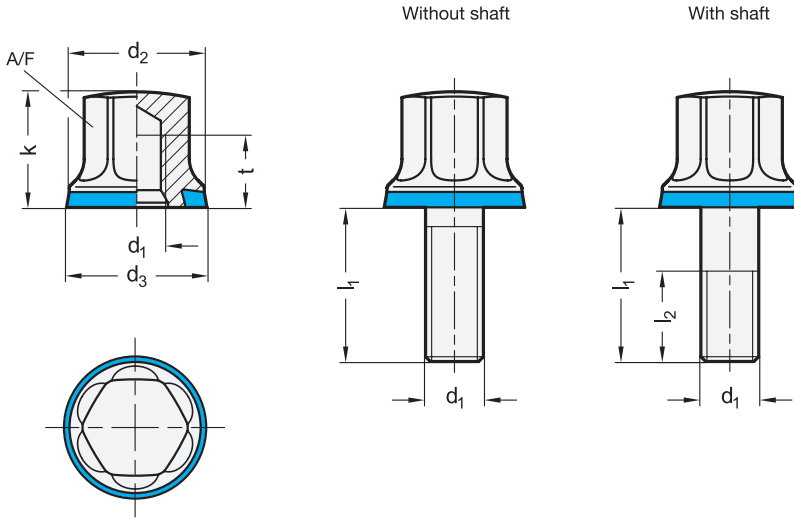
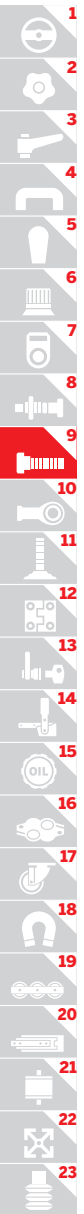

**GN 1580-Screws** STAINLESS STEEL

Description	d1	l1 without shaft	l1 with shaft	d2	d3	k	l2	A/F	⚖️
GN 1580-M4-8-MT-E	M 4	8	-	11	11.8	9.5	-	7	4
GN 1580-M4-8-PL-E	M 4	8	-	11	11.8	9.5	-	7	5
GN 1580-M4-10-MT-E	M 4	10	-	11	11.8	9.5	14	7	5
GN 1580-M4-10-PL-E	M 4	10	-	11	11.8	9.5	14	7	5
GN 1580-M4-12-MT-E	M 4	12	-	11	11.8	9.5	-	7	5
GN 1580-M4-12-PL-E	M 4	12	-	11	11.8	9.5	-	7	4
GN 1580-M4-16-MT-E	M 4	-	16	11	11.8	-	14	7	13
GN 1580-M4-16-PL-E	M 4	-	16	11	11.8	-	14	7	5
GN 1580-M5-10-MT-E	M 5	10	-	12	12.8	10	-	8	13
GN 1580-M5-10-PL-E	M 5	10	-	12	12.8	10	-	8	13
GN 1580-M5-16-MT-E	M 5	16	-	12	12.8	10	-	8	10
GN 1580-M5-16-PL-E	M 5	16	-	12	12.8	10	-	8	10
GN 1580-M5-20-MT-E	M 5	20	-	12	12.8	10	-	8	11
GN 1580-M5-20-PL-E	M 5	20	-	12	12.8	10	-	8	11
GN 1580-M6-12-MT-E	M 6	12	-	14	14.8	12	-	10	14
GN 1580-M6-12-PL-E	M 6	12	-	14	14.8	12	-	10	14
GN 1580-M6-16-MT-E	M 6	16	-	14	14.8	12	-	10	15
GN 1580-M6-16-PL-E	M 6	16	-	14	14.8	12	-	10	12
GN 1580-M6-20-MT-E	M 6	20	-	14	14.8	12	-	10	13
GN 1580-M6-20-PL-E	M 6	20	-	14	14.8	12	-	10	13
GN 1580-M6-25-MT-E	M 6	25	-	14	14.8	12	-	10	13
GN 1580-M6-25-PL-E	M 6	25	-	14	14.8	12	-	10	13
GN 1580-M6-30-MT-E	M 6	30	-	14	14.8	12	-	10	17
GN 1580-M6-30-PL-E	M 6	30	-	14	14.8	12	-	10	17
GN 1580-M8-16-MT-E	M 8	16	-	18	18.8	14.5	-	13	24
GN 1580-M8-16-PL-E	M 8	16	-	18	18.8	14.5	-	13	24
GN 1580-M8-20-MT-E	M 8	20	-	18	18.8	14.5	-	13	28
GN 1580-M8-20-PL-E	M 8	20	-	18	18.8	14.5	-	13	28
GN 1580-M8-25-MT-E	M 8	25	-	18	18.8	14.5	-	13	28
GN 1580-M8-25-PL-E	M 8	25	-	18	18.8	14.5	-	13	28
GN 1580-M8-30-MT-E	M 8	30	-	18	18.8	14.5	-	13	30
GN 1580-M8-30-PL-E	M 8	30	-	18	18.8	14.5	-	13	30
GN 1580-M8-40-MT-E	M 8	-	40	18	18.8	-	22	13	33
GN 1580-M8-40-PL-E	M 8	-	40	18	18.8	-	22	13	33

**GN 1580-Screws** STAINLESS STEEL

Description	d1	l1 without shaft	l1 with shaft	d2	d3	k	l2	A/F	⚖️
GN 1580-M10-20-MT-E	M 10	20	-	21	21.8	18	-	16	49
GN 1580-M10-20-PL-E	M 10	20	-	21	21.8	18	-	16	49
GN 1580-M10-25-MT-E	M 10	25	-	21	21.8	18	-	16	51
GN 1580-M10-25-PL-E	M 10	25	-	21	21.8	18	-	16	51
GN 1580-M10-30-MT-E	M 10	30	-	21	21.8	18	-	16	54
GN 1580-M10-30-PL-E	M 10	30	-	21	21.8	18	-	16	54
GN 1580-M10-40-MT-E	M 10	-	40	21	21.8	-	26	16	59
GN 1580-M10-40-PL-E	M 10	-	40	21	21.8	-	26	16	59
GN 1580-M10-50-MT-E	M 10	-	50	21	21.8	-	26	16	64
GN 1580-M10-50-PL-E	M 10	-	50	21	21.8	-	26	16	64
GN 1580-M12-25-PL-E	M 12	25	-	25	25.8	21	-	18	79
GN 1580-M12-25-MT-E	M 12	25	-	25	25.8	21	-	18	79
GN 1580-M12-30-PL-E	M 12	30	-	25	25.8	21	-	18	84
GN 1580-M12-30-MT-E	M 12	30	-	25	25.8	21	-	18	70
GN 1580-M12-40-PL-E	M 12	-	40	25	25.8	-	30	18	93
GN 1580-M12-40-MT-E	M 12	-	40	25	25.8	-	30	18	77
GN 1580-M12-50-PL-E	M 12	-	50	25	25.8	-	30	18	102
GN 1580-M12-50-MT-E	M 12	-	50	25	25.8	-	30	18	102
GN 1580-M12-60-PL-E	M 12	-	60	25	25.8	-	30	18	111
GN 1580-M12-60-MT-E	M 12	-	60	25	25.8	-	30	18	111
GN 1580-M16-30-PL-E	M 16	30	-	32	32.8	26	38	24	157
GN 1580-M16-30-MT-E	M 16	30	-	32	32.8	26	38	24	157
GN 1580-M16-40-PL-E	M 16	40	-	32	32.8	26	38	24	173
GN 1580-M16-40-MT-E	M 16	40	-	32	32.8	26	38	24	173
GN 1580-M16-50-PL-E	M 16	-	50	32	32.8	26	38	24	189
GN 1580-M16-50-MT-E	M 16	-	50	32	32.8	26	38	24	189
GN 1580-M16-60-PL-E	M 16	-	60	32	32.8	26	38	24	205
GN 1580-M16-60-MT-E	M 16	-	60	32	32.8	26	38	24	187
GN 1580-M16-70-PL-E	M 16	-	70	32	32.8	26	38	24	221
GN 1580-M16-70-MT-E	M 16	-	70	32	32.8	26	38	24	221
GN 1580-M20-40-MT-E	M 20	40	-	40	40.8	32	46	30	296
GN 1580-M20-40-PL-E	M 20	40	-	40	40.8	32	46	30	296
GN 1580-M20-60-MT-E	M 20	-	60	40	40.8	32	46	30	346
GN 1580-M20-60-PL-E	M 20	-	60	40	40.8	32	46	30	346