

Split hubs

SPECIFICATION

Sintered Steel
black oxidised with vapor
Cylinder head screw
Steel, black

INFORMATION

Split hubs GN 150 are distinguished by the method of simple clamping to any shaft.
This can be achieved without prior machining of the shaft, eliminating clamping parts and assembly work.
A further advantage is the positioning of the lever arm to any required position.
The shaft tolerance should be within h_{11} ; to transmit higher torques the hub can be supplied with a keyway.

Stainless Steel-Split hubs

SPECIFICATION

Stainless Steel (Sintered Steel) AISI 316L
Cylinder head screw
Stainless Steel AISI 304

INFORMATION

Split hubs GN 150.5 are distinguished by the method of simple clamping to any shaft.
This can be achieved without prior machining of the shaft, eliminating clamping parts and assembly work.
A further advantage is the positioning of the lever arm to any required position.
The shaft tolerance should be within h_1 ; to transmit higher torques the hub can be supplied with a keyway.

TECHNICAL INFORMATION

- Stainless Steel characteristics (see page A26)

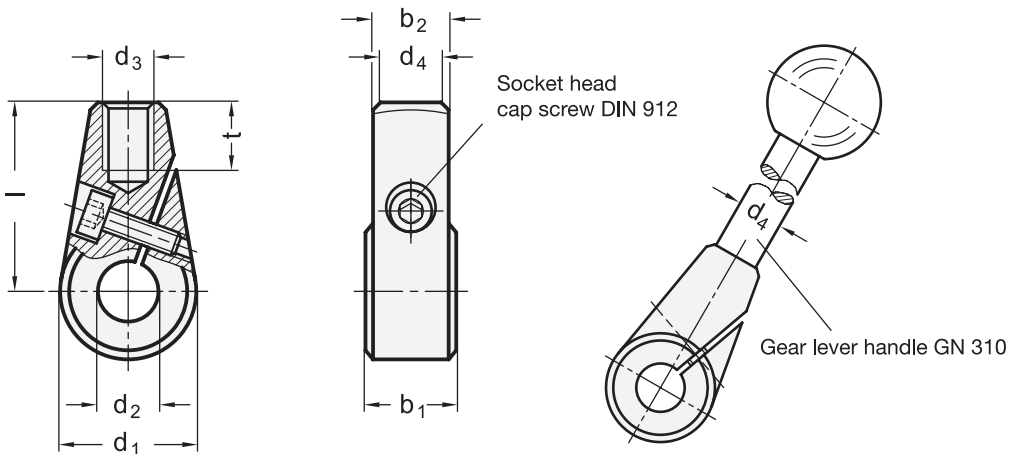

GN 150

Description	d1	d2	b1 ± 0.2	b2	d3	d4	l	t min.	Δ
GN 150-24-B10	24	B 10	15.5	13	M 8	10	36	11	64
GN 150-24-B12	24	B 12	15.5	13	M 8	10	36	11	64
GN 150-28-B12	28	B 12	17.5	15	M 10	12	41	14	100
GN 150-28-B14	28	B 14	17.5	15	M 10	12	41	14	94
GN 150-32-B14	32	B 14	19.5	17	M 12	14	45	16	140
GN 150-32-B16	32	B 16	19.5	17	M 12	14	45	16	137

GN 150.5

STAINLESS STEEL

Description	d1	d2	b1 ± 0.2	b2	d3	d4	l	t min.	Δ
GN 150.5-24-B10	24	B 10	15.5	13	M 8	10	36	11	64
GN 150.5-24-B12	24	B 12	15.5	13	M 8	10	36	11	61
GN 150.5-28-B12	28	B 12	17.5	15	M 10	12	41	14	94
GN 150.5-28-B14	28	B 14	17.5	15	M 10	12	41	14	90
GN 150.5-32-B14	32	B 14	19.5	17	M 12	14	45	16	140
GN 150.5-32-B16	32	B 16	19.5	17	M 12	14	45	16	132