



GN 120.2

Protective guide plates

for latches GN 115, GN 115.7, GN 115.10



Specification

Types

- Type **A**: Mounting with countersunk screw
- Type **B**: Mounting with adhesive pad

Plastic (Polyamide PA)

black, matt **SW**

Adhesive pad (only type B)

Scotch-Mount™ 4026

double-sided,

with polyurethane foam backing

Information

GN 120.2 protective guide plates are used in connection with door latches, using the principle of friction. They prevent the latch from causing abrasion, for example to corrosion protection layers on a door frame. They additionally prevent unintended opening, as the latches lock into a small recess in their closed position. If the d_2 positioning tabs are not required they can easily be removed with side cutting pliers, for example.

Latches that can be used together with GN 120.2 protective guide plates:

- Latches not lockable [GN 115-NL](#)
- Latches lockable [GN 115-L](#)
- Latches with key [GN 115-NL with key](#)
- Latches with cabinet "U" handle [GN 115.7](#)

Technical Information

- [Plastic characteristics](#)

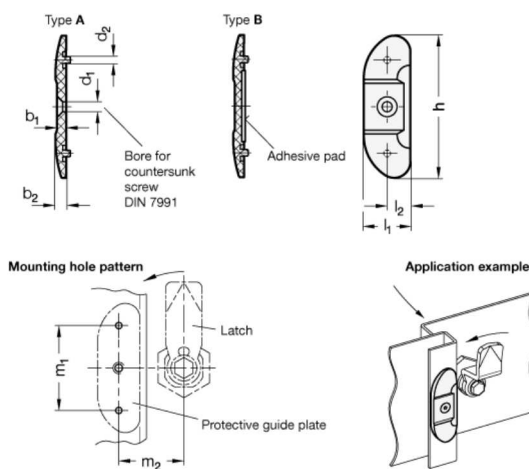

Description	d	b ₁	b ₂	d ₁	d ₂	l ₁	l ₂	m ₁	m ₂ ±2	Weight
GN 120.2-60-4-A-SW	60	4	4.6	M 6	3	20	10	40	35	3
GN 120.2-60-4-B-SW	60	4	4.6	-	3	20	10	40	35	5