

Fast Mounting Kit

Steel and rubber

NUT

Zinc-plated steel.

PACKING RING

NBR synthetic rubber.

FEATURES

The FM kit (fast mounting kit) has been designed for mounting level indicators series HCX. from the outside when nuts cannot be fitted from the inside of the reservoir.



ASSEMBLY OF THE INDICATOR WITH THE FM KIT (FAST MOUNTING KIT)

- Arrange the holes d_1 as reported in the table and make sure that the holes in the plate do not have any burrs, especially inside the reservoir.
 - Unscrew the nuts from the HCX. indicator and take out the washers supplied with the standard execution, put the packing ring inside and screw the nuts (with or without O-Ring according to the thickness h_1).
 - Before assembly of the indicator on the reservoir, slightly tighten the nut by hand against the packing ring.
- We advise you, then, to deform slightly the threaded end of the screw in order to prevent the nut from falling into the reservoir while disassembling the indicator.
- To disassemble the indicator from the reservoir, just rotate the screw 3/4 of a turn keeping the plastic part of the indicator under tension (pulling).

$1.5 < h_1 < 4.7$
(assembly without O-ring)

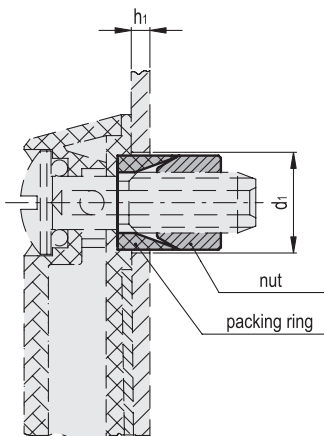

$4.7 < h_1 < 6.3$
(assembly with O-ring)

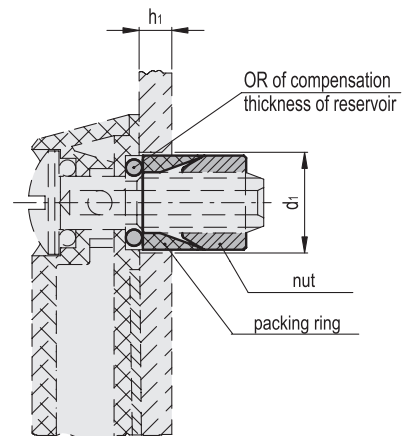

Code	Description	$d_1 \pm 0.1$	Without O-ring h_1 min	Without O-ring h_1 max	With O-ring h_1 min	With O-ring h_1 max	Tightening torque max. [Nm]
31801	FM-HCX.76-M10-KIT	16	1.5	4.7	4.7	6.3	7
31811	FM-HCX.127-254-M12-KIT	17.5	1.5	4.7	4.7	6.3	7