

## Wing knobs

with retaining chain, technopolymer

### MATERIAL

Glass-fibre reinforced polyamide based (PA) technopolymer, grey-black colour, matte finish.  
Elastic retaining ring in acetal based technopolymer (POM), black colour.

### BOSS CAP

Polyamide based (PA) technopolymer, grey-black colour, matte finish, press-fit assembly, removable by a screwdriver.

### RETAINING CHAIN

Ball cable and coupling heads in acetal resin based (POM) technopolymer, black colour.

NERINOX treated stainless steel ring with two coils.

Head fastening by means of a self-tapping screw  $\varnothing 4.8$  mm UNI EN ISO 7050 or a M5 countersunk-head screw UNI EN ISO 10642.

### STANDARD EXECUTIONS

- **EWN-B-LP**: brass boss, threaded through hole.
- **EWN-SST-LP**: AISI 303 stainless steel, threaded pass-through hole.
- **EWN-p-LP**: zinc-plated steel threaded stud, chamfered flat end according to UNI EN ISO 4753:2012 (see Technical data on page -).
- **EWN-SST-p-LP**: AISI 303 stainless steel threaded stud, chamfered flat end UNI EN ISO 4753:2012 (see Technical data on page -).

### FEATURES AND APPLICATIONS

The elastic retaining ring, housed in the groove of the wing nut can turn freely. The coiled ring connects the elastic retaining ring to the chain.

Suitable where it is necessary to prevent the loss of the wing nut.

For applications in which the fixing of the chain is at a position higher than that of the wing nut, it is advisable to leave it with slack movement to prevent the ring from touching the wing nut.

### SPECIAL EXECUTIONS ON REQUEST

- Chain in different lengths.
- Wing nut with stainless steel cable GN 111 (see page -), GN 111.2 (see page -), GN 111.4 (see page -).



EWN-B-LP  
EWN-SST-LP

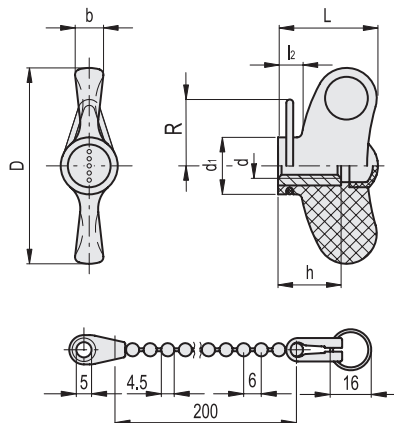

### EWN-B-LP

Code	Description	D	d6H	L	d1	l2	b	h	R	C# [Nm]	
222916-C1	EWN.48 B-M5-C1-LP	47	M5	24	13.5	5.5	7	12	20.5	10	15
222921-C1	EWN.48 B-M6-C1-LP	47	M6	24	13.5	5.5	7	12	20.5	11	14
222936-C1	EWN.55 B-M6-C1-LP	55	M6	28	16	6.5	8	18	21.5	20	24
222941-C1	EWN.55 B-M8-C1-LP	55	M8	28	16	6.5	8	18	21.5	26	23
222951-C1	EWN.63 B-M8-C1-LP	63	M8	32	19	7.5	9	20	22.5	45	33
222956-C1	EWN.63 B-M10-C1-LP	63	M10	32	19	7.5	9	20	22.5	58	32

### EWN-SST-LP

STAINLESS STEEL

Code	Description	D	d6H	L	d1	l2	b	h	R	C# [Nm]	
223001-C1	EWN.55 SST-M8-C1-LP	55	M8	28	16	6.5	8	18	21.5	26	23
223011-C1	EWN.63 SST-M10-C1-LP	63	M10	32	19	7.5	9	20	22.5	58	32

# "Max limit Tightening torque" means the max torque value at which the metal insert, in normal conditions of use, is perfectly and strongly anchored to the plastic material.

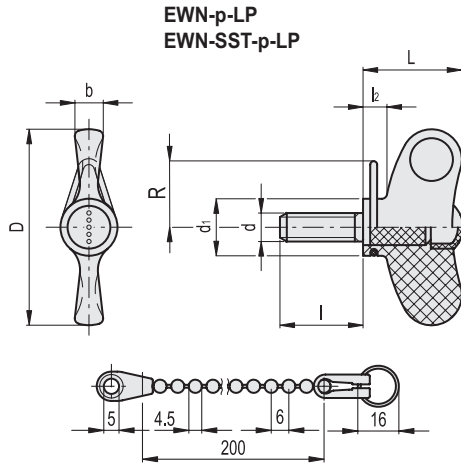

EWN-p-LP

Code	Description	D	d6g	L	d1	l	l2	b	R	C# [Nm]	⚖️
222725-C1	EWN.48 p-M5x16-C1-LP	47	M5	24	13.5	16	5.5	7	20.5	9	15
222726-C1	EWN.48 p-M5x20-C1-LP	47	M5	24	13.5	20	5.5	7	20.5	9	16
222728-C1	EWN.48 p-M5x30-C1-LP	47	M5	24	13.5	30	5.5	7	20.5	9	18
222732-C1	EWN.48 p-M6x16-C1-LP	47	M6	24	13.5	16	5.5	7	20.5	12	16
222733-C1	EWN.48 p-M6x20-C1-LP	47	M6	24	13.5	20	5.5	7	20.5	12	18
222734-C1	EWN.48 p-M6x25-C1-LP	47	M6	24	13.5	25	5.5	7	20.5	12	19
222735-C1	EWN.48 p-M6x30-C1-LP	47	M6	24	13.5	30	5.5	7	20.5	12	21
222753-C1	EWN.55 p-M8x20-C1-LP	55	M8	28	16	20	6.5	8	21.5	22	27
222755-C1	EWN.55 p-M8x30-C1-LP	55	M8	28	16	30	6.5	8	21.5	22	30
222757-C1	EWN.55 p-M8x40-C1-LP	55	M8	28	16	40	6.5	8	21.5	22	33
222761-C1	EWN.55 p-M10x20-C1-LP	55	M10	28	16	20	6.5	8	21.5	25	30
222763-C1	EWN.55 p-M10x30-C1-LP	55	M10	28	16	30	6.5	8	21.5	25	33
222765-C1	EWN.55 p-M10x40-C1-LP	55	M10	28	16	40	6.5	8	21.5	25	36
222771-C1	EWN.63 p-M8x20-C1-LP	63	M8	32	19	20	7.5	9	22.5	32	34
222773-C1	EWN.63 p-M8x30-C1-LP	63	M8	32	19	30	7.5	9	22.5	32	37
222775-C1	EWN.63 p-M8x40-C1-LP	63	M8	32	19	40	7.5	9	22.5	32	39
222781-C1	EWN.63 p-M10x20-C1-LP	63	M10	32	19	20	7.5	9	22.5	48	40
222783-C1	EWN.63 p-M10x30-C1-LP	63	M10	32	19	30	7.5	9	22.5	48	43
222785-C1	EWN.63 p-M10x40-C1-LP	63	M10	32	19	40	7.5	9	22.5	48	52

EWN-SST-p-LP

STAINLESS STEEL

Code	Description	D	d6g	L	d1	l	l2	b	R	C# [Nm]	⚖️
222833-C1	EWN.48 SST-p-M6x20-C1-LP	47	M6	24	13.5	20	5.5	7	20.5	11	17
222835-C1	EWN.48 SST-p-M6x30-C1-LP	47	M6	24	13.5	30	5.5	7	20.5	11	19
222842-C1	EWN.48 SST-p-M8x20-C1-LP	47	M8	24	13.5	20	5.5	7	20.5	11	20
222844-C1	EWN.48 SST-p-M8x30-C1-LP	47	M8	24	13.5	30	5.5	7	20.5	11	23
222846-C1	EWN.48 SST-p-M8x40-C1-LP	47	M8	24	13.5	40	5.5	7	20.5	11	26
222853-C1	EWN.55 SST-p-M8x20-C1-LP	55	M8	28	16	20	6.5	8	21.5	22	27
222855-C1	EWN.55 SST-p-M8x30-C1-LP	55	M8	28	16	30	6.5	8	21.5	22	30
222857-C1	EWN.55 SST-p-M8x40-C1-LP	55	M8	28	16	40	6.5	8	21.5	22	34
222881-C1	EWN.63 SST-p-M10x20-C1-LP	63	M10	32	19	20	7.5	9	22.5	48	40
222883-C1	EWN.63 SST-p-M10x30-C1-LP	63	M10	32	19	30	7.5	9	22.5	48	44
222885-C1	EWN.63 SST-p-M10x40-C1-LP	63	M10	32	19	40	7.5	9	22.5	48	52

# "Max limit Tightening torque" means the max torque value at which the metal insert, in normal conditions of use, is perfectly and strongly anchored to the plastic material.



2

Clamping knobs