

Flush pull handles

for snap-in assembly, technopolymer

STANDARD EXECUTIONS

Snap-in assembly (see Assembly Instructions).

- **EPR-PF:** glass-fibre reinforced polyamide based (PA) technopolymer, grey-black colour, matte finish.
- **EPR-PF-CLEAN:** glass-fibre reinforced polyamide based (PA) technopolymer, white colour similar to RAL 9002, matte finish.

ERGONOMY AND DESIGN

A modern design thanks to the compact shape. The internal profile of the cavity offers a safe, comfortable and ergonomic grip. EPR-PF CLEAN in white colour is particularly suitable for application medical and hospital equipment and for food processing machines.

TECHNICAL DATA

The lifting (F1) and pull out (F2) resistance values reported in the table are the result of the tests carried out in laboratory with handles assembled on strengthened metal sheet panels with thickness = 1.5 mm (strengthened for test purposes).

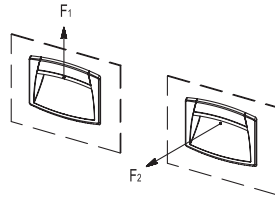

s	EPR.90-PF		EPR.110-PF		EPR.120-PF	
	x	y	x	y	x	y
0.7	85 +0.2	34.9 ±0.1	100 ±0.2	49.7 ±0.1	107.5 ±0.2	70.5 ±0.1
1	85 +0.2	35.1 ±0.1	100.2 ±0.2	50 ±0.1	107.5 ±0.2	70.8 ±0.1
1.5	85 +0.2	36.1 ±0.1	100 ±0.2	50.4 ±0.1	107.5 ±0.2	71.2 ±0.1
2	85 +0.2	36.1 ±0.1	100 ±0.2	50.7 ±0.1	107.5 ±0.2	71.5 ±0.1
2.2	85 +0.2	36.1 ±0.1	100 ±0.2	50.7 ±0.1	107.5 ±0.2	71.5 ±0.1

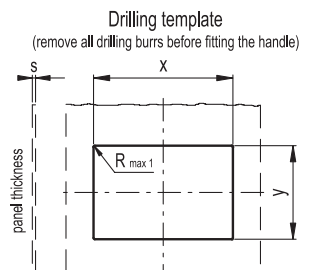

ASSEMBLY INSTRUCTIONS

1. Drill the handle housing according to the template dimensions reported in the table.
2. Remove all drilling burrs before fitting the handle.
3. Fit the upper part of the handle into the housing (Fig. 1).
4. Press onto the lower part until the handle is completely snapped in (Fig. 2).

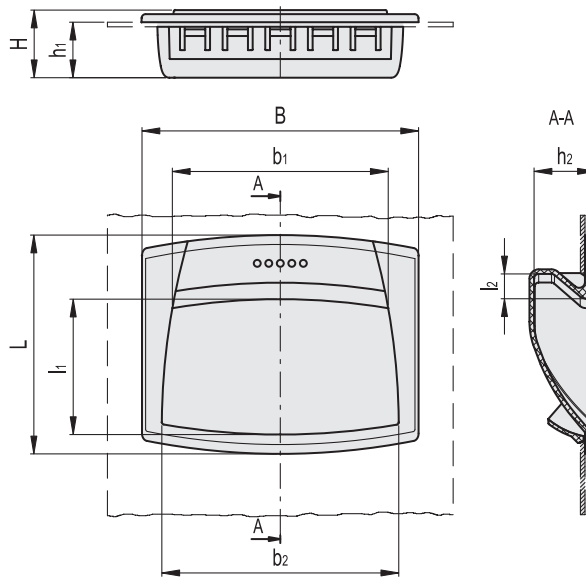
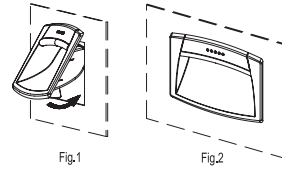

EPR-PF

Code	Description	B	L	H	h1	h2	b1	b2	l1	l2	F1 [N]	F2 [N]	⚖
261051-C1	EPR.90-PF-C1	90	50	19	17	17.5	76	79	28	7	1800	500	20
261081-C1	EPR.110-PF-C1	109	73	24	20	21.5	91	96	42	9	1300	400	45
261111-C1	EPR.120-PF-C1	120	95	28.5	24	26.5	94	103	58	11	1000	250	58

EPR-PF-CLEAN

Code	Description	B	L	H	h1	h2	b1	b2	l1	l2	F1 [N]	F2 [N]	⚖
151001	EPR.90-PF-CLEAN	90	50	19	17	17.5	76	79	28	7	1800	500	20
151005	EPR.110-PF-CLEAN	109	73	24	20	21.5	91	96	42	9	1300	400	45
151011	EPR.120-PF-CLEAN	120	95	28.5	24	26.5	94	103	58	11	1000	250	58

