

# DIN 908

Threaded plugs

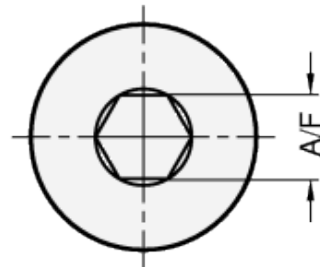
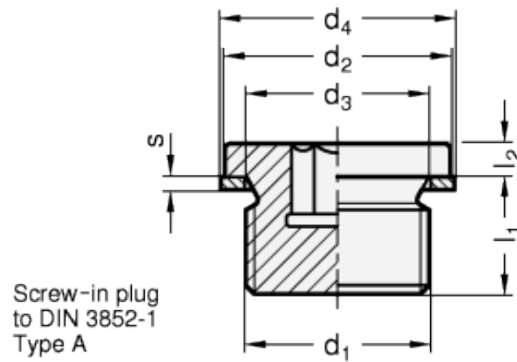

## technical informations

### Material

Steel, class 5.8 (tensile strength 500 N/mm<sup>2</sup>).  
Zinc-plated steel, blue passivated (silver / yellowish).  
Ultrasonically and tensile tested.

### Standard versions available

- Type A: without gasket.
- Type AC: with gasket copper.
- Type AA: with gasket aluminium.

*Special executions on request (For sufficient quantities)*

Threaded plugs in Stainless Steel (NI).

*Features and applications*

The gaskets in types AC and AA correspond to the gaskets DIN 7603, type A (flat gaskets).

Standard Elements	Main dimensions								Weight
Description	d <sub>1</sub>	d <sub>2h14</sub>	d <sub>3</sub>	d <sub>4</sub>	l <sub>1±0.2</sub>	l <sub>2±0.5</sub>	s	A/F	g
DIN 908-ST-M8x1-A	M8x1	12	8.3	-	8	3	1	4	4
DIN 908-ST-M10x1-A	M10x1	14	10.3	-	8	3	1	5	6
DIN 908-ST-M12x1.5-A	M12x1.5	17	12.3	-	12	3	1.5	6	11
DIN 908-ST-M14x1.5-A	M14x1.5	19	14.3	-	12	3	1.5	6	16
DIN 908-ST-M16x1.5-A	M16x1.5	21	16.3	-	12	3	1.5	8	20
DIN 908-ST-M18x1.5-A	M18x1.5	23	18.3	-	12	4	1.5	8	29
DIN 908-ST-M20x1.5-A	M20x1.5	25	20.3	-	14	4	1.5	10	38
DIN 908-ST-M22x1.5-A	M22x1.5	27	22.3	-	14	4	1.5	10	42
DIN 908-ST-M24x1.5-A	M24x1.5	29	24.3	-	14	4	2	12	53
DIN 908-ST-M26x1.5-A	M26x1.5	31	26.3	-	16	4	2	12	73
DIN 908-ST-M27x2-A	M27x2	32	27.3	-	16	4	2	12	75
DIN 908-ST-M30x1.5-A	M30x1.5	36	30.3	-	16	4	2	17	84
DIN 908-ST-M33x2-A	M33x2	39	33.3	-	16	5	2	17	119
DIN 908-ST-M42x2-A	M42x2	49	42.3	-	16	5	2	22	187
DIN 908-ST-M48x2-A	M48x2	55	48.3	-	16	5	2	24	240
DIN 908-ST-G1/8-A	G1/8	14	10	-	8	3	1	6	6
DIN 908-ST-G1/4-A	G1/4	18	13.4	-	12	3	1.5	6	14
DIN 908-ST-G3/8-A	G3/8	22	17	-	12	3	1.5	8	22
DIN 908-ST-G1/2-A	G1/2	26	21.3	-	14	4	1.5	10	41
DIN 908-ST-G3/4-A	G3/4	32	26.7	-	16	4	2	12	53
DIN 908-ST-G1-A	G1	39	33.5	-	16	5	2	17	119
DIN 908-ST-G1 1/4-A	G1 1/4	49	42.2	-	16	5	2	22	185
DIN 908-ST-G1 1/2-A	G 1 1/2	55	48.1	-	16	5	2	24	237
DIN 908-ST-M8x1-AC	M8x1	12	8.3	11.5	8	3	1	4	5
DIN 908-ST-M10x1-AC	M10x1	14	10.3	13.5	8	3	1	5	7
DIN 908-ST-M12x1.5-AC	M12x1.5	17	12.3	16	12	3	1.5	6	12
DIN 908-ST-M14x1.5-AC	M14x1.5	19	14.3	18	12	3	1.5	6	17
DIN 908-ST-M16x1.5-AC	M16x1.5	21	16.3	20	12	3	1.5	8	21
DIN 908-ST-M18x1.5-AC	M18x1.5	23	18.3	22	12	4	1.5	8	30
DIN 908-ST-M20x1.5-AC	M20x1.5	25	20.3	24	14	4	1.5	10	40
DIN 908-ST-M22x1.5-AC	M22x1.5	27	22.3	27	14	4	1.5	10	44
DIN 908-ST-M24x1.5-AC	M24x1.5	29	24.3	29	14	4	2	12	56
DIN 908-ST-M26x1.5-AC	M26x1.5	31	26.3	31	16	4	2	12	76
DIN 908-ST-M27x2-AC	M27x2	32	27.3	32	16	4	2	12	79
DIN 908-ST-M30x1.5-AC	M30x1.5	36	30.3	36	16	4	2	17	88
DIN 908-ST-M33x2-AC	M33x2	39	33.3	39	16	5	2	17	124

DIN 908-ST-M42x2-AC	M42x2	49	42.3	49	16	5	2	22	194
DIN 908-ST-M48x2-AC	M48x2	55	48.3	55	16	5	2	24	248
DIN 908-ST-G1/8-AC	G1/8	14	10	13.5	8	3	1	6	7
DIN 908-ST-G1/4-AC	G1/4	18	13.4	18	12	3	1.5	6	15
DIN 908-ST-G3/8-AC	G3/8	22	17	21	12	3	1.5	8	24
DIN 908-ST-G1/2-AC	G1/2	26	21.3	26	14	4	1.5	10	43
DIN 908-ST-G3/4-AC	G3/4	32	26.7	32	16	4	2	12	56
DIN 908-ST-G1-AC	G1	39	33.5	39	16	5	2	17	124
DIN 908-ST-G1 1/4-AC	G1 1/4	49	42.2	49	16	5	2	22	192
DIN 908-ST-G1 1/2-AC	G1 1/2	55	48.1	55	16	5	2	24	244
DIN 908-ST-M8x1-AA	M8x1	12	8.3	11.5	8	3	1	4	5
DIN 908-ST-M10x1-AA	M10x1	14	10.3	13.5	8	3	1	5	7
DIN 908-ST-M12x1.5-AA	M12x1.5	17	12.3	16	12	3	1.5	6	12
DIN 908-ST-M14x1.5-AA	M14x1.5	19	14.3	18	12	3	1.5	6	17
DIN 908-ST-M16x1.5-AA	M16x1.5	21	16.3	20	12	3	1.5	8	21
DIN 908-ST-M18x1.5-AA	M18x1.5	23	18.3	22	12	4	1.5	8	30
DIN 908-ST-M20x1.5-AA	M20x1.5	25	20.3	24	14	4	1.5	10	40
DIN 908-ST-M22x1.5-AA	M22x1.5	27	22.3	27	14	4	1.5	10	44
DIN 908-ST-M24x1.5-AA	M24x1.5	29	24.3	29	14	4	2	12	56
DIN 908-ST-M26x1.5-AA	M26x1.5	31	26.3	31	16	4	2	12	76
DIN 908-ST-M27x2-AA	M27x2	32	27.3	32	16	4	2	12	79
DIN 908-ST-M30x1.5-AA	M30x1.5	36	30.3	36	16	4	2	17	88
DIN 908-ST-M33x2-AA	M33x2	39	33.3	39	16	5	2	17	124
DIN 908-ST-M42x2-AA	M42x2	49	42.3	49	16	5	2	22	194
DIN 908-ST-M48x2-AA	M48x2	55	48.3	55	16	5	2	24	248
DIN 908-ST-G1/8-AA	G1/8	14	10	13.5	8	3	1	6	7
DIN 908-ST-G1/4-AA	G1/4	18	13.4	18	12	3	1.5	6	15
DIN 908-ST-G3/8-AA	G3/8	22	17	21	12	3	1.5	8	24
DIN 908-ST-G1/2-AA	G1/2	26	21.3	26	14	4	1.5	10	43
DIN 908-ST-G3/4-AA	G3/4	32	26.7	32	16	4	2	12	56
DIN 908-ST-G1-AA	G1	39	33.5	39	16	5	2	17	124
DIN 908-ST-G1 1/4-AA	G1 1/4	49	42.2	49	16	5	2	22	192
DIN 908-ST-G1 1/2-AA	G1 1/2	55	48.1	55	16	5	2	24	244



STANDARD MACHINE ELEMENTS WORLDWIDE