

## Universal joints

Steel / Stainless Steel, single or double

### SPECIFICATION

#### Universal joints with friction bearing

##### Version in Steel

##### Types

- Type **EG**: single, friction bearing
- Type **DG**: double, friction bearing

##### Bore codes

- Version **B**: without keyway
- Version **K**: with keyway
- Version **V**: with square

Steel  
blank

Joint bearing areas / pins / bearing sleeves  
case hardened

##### Version in Stainless Steel

##### Types

- Type **EG**: single, friction bearing
- Type **DG**: double, friction bearing

##### Bore code

- Version **B**: without keyway
- Version **K**: with keyway
- Version **V**: with square

Stainless Steel AISI 304 NI

#### Universal joints with needle bearing

##### Types

- Type **EW**: single, needle bearing
- Type **DW**: double, needle bearing

##### Bore codes

- Version **B**: without keyway
- Version **K**: with keyway
- Version **V**: with square

Steel  
blank

Joint bearing areas, pins  
case hardened



### INFORMATION

The permissible r.p.m. of universal joints with friction bearing DIN 808 is to a large extent dependent on the type of application such as load, duration, angular disposition as well as lubrication. For over 1000 r.p.m. universal joints with needle bearing should be used. For continuous use ample lubrication is essential. This is achieved by fitting the joint with a grease filled gaiter GN 808.1 (see page 1131).

### ON REQUEST

- with other or unequal bores

### TECHNICAL INFORMATION

- Permissible r.p.m. and torque (see page 1124)
- Keyway DIN 6885 (see page A16)
- Cross holes GN 110.1 (see page A18)
- Stainless Steel characteristics (see page A26)
- ISO-Fundamental Tolerances (see page A21)

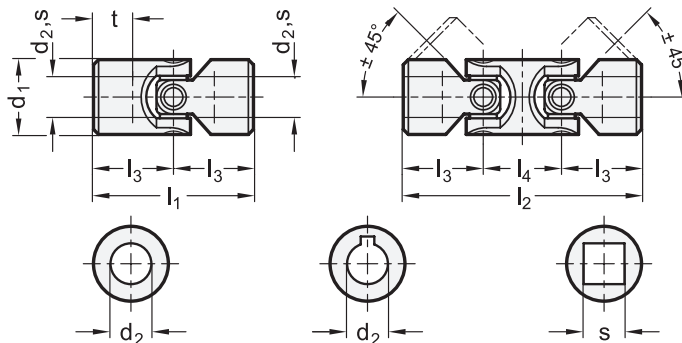

DIN 808

### DIN 808-friction bearing

Description	d1	d2 H7	l1	l2	l3	l4	t+1 max. assembly length of the shaft	⚖
DIN 808-16-B6-34-EG	16	B 6	34	-	17	22	8	40
DIN 808-16-B6-56-DG	16	B 6	-	56	17	22	8	60
DIN 808-16-B8-40-EG	16	B 8	40	-	20	22	11	40
DIN 808-16-B8-62-DG	16	B 8	-	62	20	22	11	65
DIN 808-16-B10-52-EG	16	B 10	52	-	26	22	14	49
DIN 808-16-B10-74-DG	16	B 10	-	74	26	22	14	70
DIN 808-22-B10-48-EG	22	B 10	48	-	24	26	12	95
DIN 808-22-B10-74-DG	22	B 10	-	74	24	26	12	145
DIN 808-22-B12-62-EG	22	B 12	62	-	31	26	18	119
DIN 808-22-B12-88-DG	22	B 12	-	88	31	26	18	167
DIN 808-25-B12-56-EG	25	B 12	56	-	28	30	13	147
DIN 808-25-B12-86-DG	25	B 12	-	86	28	30	13	220
DIN 808-25-B16-74-EG	25	B 16	74	-	37	30	21	140
DIN 808-25-B16-104-DG	25	B 16	-	104	37	30	21	185
DIN 808-28-B14-60-EG	28	B 14	60	-	30	36	13	195
DIN 808-28-B14-96-DG	28	B 14	-	96	30	36	13	286
DIN 808-32-B16-68-EG	32	B 16	68	-	34	37	16	324
DIN 808-32-B16-104-DG	32	B 16	-	104	34	37	16	430
DIN 808-32-B20-86-EG	32	B 20	86	-	43	38	24	382
DIN 808-32-B20-124-DG	32	B 20	-	124	43	38	24	462
DIN 808-36-B18-74-EG	36	B 18	74	-	37	40	17	565
DIN 808-36-B18-114-DG	36	B 18	-	114	37	40	17	599
DIN 808-42-B20-82-EG	42	B 20	82	-	41	46	18	700
DIN 808-42-B20-128-DG	42	B 20	-	128	41	46	18	895
DIN 808-42-B25-108-EG	42	B 25	108	-	54	48	31	781
DIN 808-42-B25-156-DG	42	B 25	-	156	54	48	31	1035
DIN 808-45-B22-95-EG	45	B 22	95	-	47.5	50	22	1137
DIN 808-45-B22-145-DG	45	B 22	-	145	47.5	50	22	2220
DIN 808-50-B25-108-EG	50	B 25	108	-	54	55	26	1248
DIN 808-50-B25-163-DG	50	B 25	-	163	54	55	26	1620
DIN 808-50-B30-132-EG	50	B 30	132	-	66	56	38	1660
DIN 808-50-B30-188-DG	50	B 30	-	188	66	56	38	1248
DIN 808-58-B30-122-EG	58	B 30	122	-	61	68	29	1724
DIN 808-58-B30-190-DG	58	B 30	-	190	61	68	29	2528
DIN 808-58-B32-130-EG	58	B 32	130	-	65	68	33	1724
DIN 808-58-B32-198-DG	58	B 32	-	198	65	68	33	2619
DIN 808-70-B35-140-EG	70*	B 35	140	-	70	72	35	278
DIN 808-70-B35-212-DG	70*	B 35	-	212	70	72	35	375
DIN 808-16-K6-34-EG	16	K 6	34	-	17	22	8	39
DIN 808-16-K6-56-DG	16	K 6	-	56	17	22	8	62
DIN 808-16-K8-40-EG	16	K 8	40	-	20	22	11	40
DIN 808-16-K8-62-DG	16	K 8	-	62	20	22	11	65
DIN 808-16-K10-52-EG	16	K 10	52	-	26	22	14	47
DIN 808-16-K10-74-DG	16	K 10	-	74	26	22	14	69
DIN 808-22-K10-48-EG	22	K 10	48	-	24	26	12	96
DIN 808-22-K10-74-DG	22	K 10	-	74	24	26	12	144
DIN 808-22-K12-62-EG	22	K 12	62	-	31	26	18	118
DIN 808-22-K12-88-DG	22	K 12	-	88	31	26	18	157
DIN 808-25-K12-56-EG	25	K 12	56	-	28	30	13	163
DIN 808-25-K12-86-DG	25	K 12	-	86	28	30	13	222
DIN 808-25-K16-74-EG	25	B 16	74	-	37	30	21	163
DIN 808-25-K16-104-DG	25	B 16	-	104	37	30	21	222
DIN 808-28-K14-60-EG	28	B 14	60	-	30	36	13	185
DIN 808-28-K14-96-DG	28	K 14	-	96	30	36	13	285
DIN 808-32-K16-68-EG	32	K 16	68	-	34	37	16	283
DIN 808-32-K16-104-DG	32	K 16	-	104	34	37	16	426
DIN 808-32-K20-86-EG	32	K 20	86	-	43	38	24	317
DIN 808-32-K20-124-DG	32	K 20	-	124	43	38	24	460

DIN 808

\* not available from stock, requires a minimum order quantity

### DIN 808-friction bearing

Description	d1	d2 H7	s H10	l1	l2	l3	l4	t+1 max. assembly length of the shaft	⚖
DIN 808-36-K18-74-EG	36	K 18	-	74	-	37	40	17	375
DIN 808-36-K18-114-DG	36	K 18	-	-	114	37	40	17	565
DIN 808-42-K20-82-EG	42	K 20	-	82	-	41	46	18	595
DIN 808-42-K20-128-DG	42	K 20	-	-	128	41	46	18	905
DIN 808-42-K25-108-EG	42	K 25	-	108	-	54	48	31	715
DIN 808-42-K25-156-DG	42	K 25	-	-	156	54	48	31	1026
DIN 808-45-K22-95-EG	45	K 22	-	95	-	47.5	50	22	773
DIN 808-45-K22-145-DG	45	K 22	-	-	145	47.5	50	22	1121
DIN 808-50-K25-108-EG	50	K 25	-	108	-	54	55	26	1098
DIN 808-50-K25-163-DG	50	K 25	-	-	163	54	55	26	1600
DIN 808-50-K30-132-EG	50	K 30	-	132	-	66	56	38	1241
DIN 808-50-K30-188-DG	50	K 30	-	-	188	66	56	38	17557
DIN 808-58-K30-122-EG	58	K 30	-	122	-	61	68	29	1646
DIN 808-58-K30-190-DG	58	K 30	-	-	190	61	68	29	2507
DIN 808-58-K32-130-EG	58	K 32	-	130	-	65	68	33	1703
DIN 808-58-K32-198-DG	58	K 32	-	-	198	65	68	33	2598
DIN 808-70-K35-140-EG	70*	K 35	-	140	-	70	72	35	40
DIN 808-70-K35-212-DG	70*	K 35	-	-	212	70	72	35	60
DIN 808-16-V6-34-EG	16	-	V 6*	34	-	17	22	8	40
DIN 808-16-V6-56-DG	16	-	V 6*	-	56	17	22	8	64
DIN 808-16-V8-40-EG	16	-	V 8*	40	-	20	22	11	56
DIN 808-16-V8-62-DG	16	-	V 8*	-	62	20	22	11	75
DIN 808-16-V8-52-EG	16	-	V 8*	52	-	26	22	14	100
DIN 808-16-V8-74-DG	16	-	V 8*	-	74	26	22	14	142
DIN 808-22-V10-48-EG	22	-	V 10*	48	-	24	26	12	123
DIN 808-22-V10-74-DG	22	-	V 10*	-	74	24	26	12	178
DIN 808-22-V10-62-EG	22	-	V 10*	62	-	31	26	18	145
DIN 808-22-V10-88-DG	22	-	V 10*	-	88	31	26	18	215
DIN 808-25-V12-56-EG	25	-	V 12*	56	-	28	30	13	189
DIN 808-25-V12-86-DG	25	-	V 12*	-	86	28	30	13	215
DIN 808-25-V12-74-EG	25	-	V 12*	74	-	37	30	21	230
DIN 808-25-V12-104-DG	25	-	V 12*	-	104	34	30	21	275
DIN 808-28-V14-60-EG	28	-	V 14*	60	-	30	36	13	348
DIN 808-28-V14-96-DG	28	-	V 14*	-	96	30	36	13	420
DIN 808-32-V16-68-EG	32	-	V 16*	68	-	34	37	16	274
DIN 808-32-V16-104-DG	32	-	V 16*	-	104	34	37	16	420
DIN 808-32-V16-86-EG	32	-	V 16*	86	-	43	38	24	274
DIN 808-32-V16-124-DG	32	-	V 16*	-	124	43	38	24	488
DIN 808-36-V18-74-EG	36	-	V 18*	74	-	37	40	17	366
DIN 808-36-V18-114-DG	36	-	V 18*	-	114	37	40	17	536
DIN 808-42-V20-82-EG	42	-	V 20*	82	-	41	46	18	580
DIN 808-42-V20-128-DG	42	-	V 20*	-	128	41	46	18	743
DIN 808-42-V20-108-EG	42	-	V 20*	108	-	54	48	31	774
DIN 808-42-V20-156-DG	42	-	V 20*	-	156	54	48	31	1009
DIN 808-45-V22-95-EG	45	-	V 22*	95	-	47.5	50	22	1000
DIN 808-45-V22-145-DG	45	-	V 22*	-	145	47.5	50	22	1009
DIN 808-50-V25-108-EG	50	-	V 25*	108	-	54	55	26	1025
DIN 808-50-V25-163-DG	50	-	V 25*	-	163	54	55	26	1565
DIN 808-50-V25-132-EG	50	-	V 25*	132	-	66	56	38	1050
DIN 808-50-V25-188-DG	50	-	V 25*	-	188	66	56	38	1790
DIN 808-58-V30-122-EG	58	-	V 30*	122	-	61	68	29	1565
DIN 808-58-V30-190-DG	58	-	V 30*	-	190	61	68	29	2420
DIN 808-58-V30-130-EG	58	-	V 30*	130	-	65	68	33	1600
DIN 808-58-V30-198-DG	58	-	V 30*	-	198	65	68	33	2500
DIN 808-70-V35-140-EG	70*	-	V 35*	140	-	70	72	35	2650
DIN 808-70-V35-212-DG	70*	-	V 35*	-	212	70	72	35	2800

\* not available from stock, requires a minimum order quantity



Joins 10

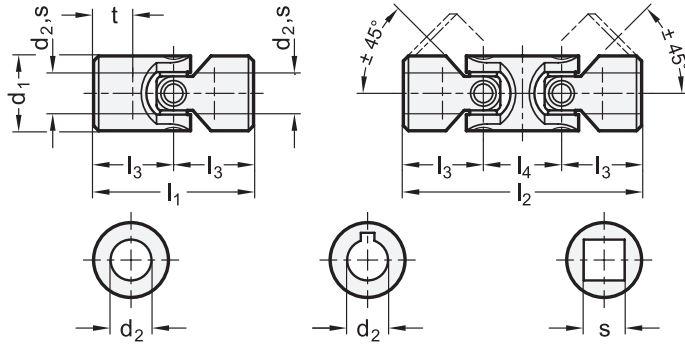

DIN 808-NI friction bearing

STAINLESS STEEL

Description	d1	d2 H7	s H10	l1	l2	l3	l4	t+1 max. assembly length of the shaft	
DIN 808-16-B6-34-EG-NI	16	B 6	-	34	-	54	22	8	40
DIN 808-16-B6-56-DG-NI	16	B 6	-	-	56	54	22	8	60
DIN 808-16-B8-40-EG-NI	16	B 8	-	40	-	66	22	11	33
DIN 808-16-B8-62-DG-NI	16	B 8	-	-	62	66	22	11	65
DIN 808-22-B10-48-EG-NI	22	B 10	-	48	-	61	26	12	100
DIN 808-22-B10-74-DG-NI	22	B 10	-	-	74	61	26	12	150
DIN 808-25-B12-56-EG-NI	25	B 12	-	56	-	65	30	13	150
DIN 808-25-B12-86-DG-NI	25	B 12	-	-	86	65	30	13	225
DIN 808-32-B16-68-EG-NI	32	B 16	-	68	-	70	36	16	290
DIN 808-32-B16-104-DG-NI	32	B 16	-	-	104	70	37	16	144
DIN 808-42-B20-82-EG-NI	42	B 20	-	82	-	24	46	18	600
DIN 808-42-B20-128-DG-NI	42	B 20	-	-	128	24	46	18	919
DIN 808-50-B25-108-EG-NI	50	B 25	-	108	-	31	55	26	1130
DIN 808-50-B25-163-DG-NI	50	B 25	-	-	163	31	55	26	1620
DIN 808-16-K6-34-EG-NI	16	K 6	-	34	-	28	22	8	38
DIN 808-16-K6-56-DG-NI	16	K 6	-	-	56	28	22	8	65
DIN 808-16-K8-40-EG-NI	16	K 8	-	40	-	37	22	11	40
DIN 808-16-K8-62-DG-NI	16	K 8	-	-	62	37	22	11	65
DIN 808-22-K10-48-EG-NI	22	K 10	-	48	-	30	26	12	97
DIN 808-22-K10-74-DG-NI	22	K 10	-	-	74	30	26	12	144
DIN 808-25-K12-56-EG-NI	25	K 12	-	56	-	34	30	13	146
DIN 808-25-K12-86-DG-NI	25	K 12	-	-	86	34	30	13	219
DIN 808-32-K16-68-EG-NI	32	K 16	-	68	-	43	36	16	289
DIN 808-32-K16-104-DG-NI	32	K 16	-	-	104	43	36	16	427
DIN 808-42-K20-82-EG-NI	42	K 20	-	82	-	37	46	18	598
DIN 808-42-K20-128-DG-NI	42	K 20	-	-	128	37	46	18	900
DIN 808-50-K25-108-EG-NI	50	K 25	-	108	-	41	55	26	1098
DIN 808-50-K25-163-DG-NI	50	K 25	-	-	163	41	55	26	1628
DIN 808-16-V6-34-EG-NI	16	-	V6*	34	-	54	22	8	40
DIN 808-16-V6-56-DG-NI	16	-	V6*	-	56	54	22	8	60
DIN 808-16-V8-40-EG-NI	16	-	V8*	40	-	47.5	22	11	40
DIN 808-16-V8-62-DG-NI	16	-	V8*	-	62	47.5	22	11	64
DIN 808-22-V10-48-EG-NI	22	-	V10*	48	-	54	26	12	100
DIN 808-22-V10-74-DG-NI	22	-	V10*	-	74	54	26	12	145
DIN 808-25-V12-56-EG-NI	25	-	V12*	56	-	66	30	13	140
DIN 808-25-V12-86-EG-NI	25	-	V12*	-	86	66	30	13	219
DIN 808-32-V16-68-EG-NI	32	-	V16*	68	-	61	36	16	274
DIN 808-32-V16-104-EG-NI	32	-	V16*	-	104	61	36	16	427
DIN 808-42-V20-82-EG-NI	42	-	V20*	82	-	65	46	18	570
DIN 808-42-V20-128-EG-NI	42	-	V20*	-	128	65	46	18	886
DIN 808-50-V25-108-EG-NI	50	-	V25*	108	-	70	55	26	1065
DIN 808-50-V25-163-EG-NI	50	-	DIN 808	-	163	70	55	26	1400

\* not available from stock, requires a minimum order quantity





10  
Joints

DIN 808-needle bearing

Description	d1	d2 H7	l1	l2	l3	l4	t+1 max. assembly length of the shaft	⚖
DIN 808-22-B10-48-EW	22	B 10	48	-	17	26	12	95
DIN 808-22-B10-74-DW	22	B 10	-	74	17	26	12	140
DIN 808-22-B12-62-EW	22	B 12	62	-	20	26	18	118
DIN 808-22-B12-88-DW	22	B 12	-	88	20	26	18	170
DIN 808-25-B12-56-EW	25	B 12	56	-	24	30	13	145
DIN 808-25-B12-86-DW	25	B 12	-	86	24	30	13	216
DIN 808-25-B16-74-EW	25	B 16	74	-	28	30	21	165
DIN 808-25-B16-104-DW	25	B 16	-	104	28	30	21	183
DIN 808-28-B14-60-EW	28	B 14	60	-	34	36	13	183
DIN 808-28-B14-96-DW	28	B 14	-	96	34	36	13	284
DIN 808-32-B16-68-EW	32	B 16	68	-	41	37	16	424
DIN 808-32-B16-104-DW	32	B 16	-	104	41	37	16	320
DIN 808-32-B20-86-EW	32	B 20	86	-	54	38	24	320
DIN 808-32-B20-124-DW	32	B 20	-	124	54	38	24	461
DIN 808-36-B18-74-EW	36	B 18	74	-	17	40	17	378
DIN 808-36-B18-114-DW	36	B 18	-	114	17	40	17	554
DIN 808-42-B20-82-EW	42	B 20	82	-	20	46	18	450
DIN 808-42-B20-128-DW	42	B 20	-	128	20	46	18	898
DIN 808-42-B25-108-EW	42	B 25	108	-	24	48	31	718
DIN 808-42-B25-156-DW	42	B 25	-	156	24	48	31	1025
DIN 808-45-B22-95-EW	45	B 22	95	-	28	50	22	771
DIN 808-45-B22-145-DW	45	B 22	-	145	28	50	22	1125
DIN 808-50-B25-108-EW	50	B 25	108	-	34	55	26	1095
DIN 808-50-B25-163-DW	50	B 25	-	163	34	55	26	1594
DIN 808-50-B30-132-EW	50	B 30	132	-	41	56	38	1234
DIN 808-50-B30-188-DW	50	B 30	-	188	41	56	38	1751
DIN 808-58-B30-122-EW	58	B 30	122	-	54	68	29	1633
DIN 808-58-B30-190-DW	58	B 30	-	190	54	68	29	2496
DIN 808-58-B32-130-EW	58	B 32	130	-	17	68	33	1723
DIN 808-58-B32-198-DW	58	B 32	-	198	17	68	33	2532
DIN 808-70-B35-140-EW	70*	B 35	140	-	20	72	35	2600
DIN 808-70-B35-212-DW	70*	B 35	-	212	20	72	35	3200
DIN 808-22-K10-48-EW	22	K 10	48	-	24	26	12	95
DIN 808-22-K10-74-DW	22	K 10	-	74	24	26	12	141
DIN 808-22-K12-62-EW	22	K 12	62	-	28	26	18	116
DIN 808-22-K12-88-DW	22	K 12	-	88	28	26	18	163
DIN 808-25-K12-56-EW	25	K 12	56	-	34	30	13	142
DIN 808-25-K12-86-DW	25	K 12	-	86	34	30	13	212
DIN 808-25-K16-74-EW	25	K 16	74	-	41	30	21	162
DIN 808-25-K16-104-DW	25	K 16	-	104	41	30	21	180
DIN 808-28-K14-60-EW	28	K 14	60	-	54	36	13	180
DIN 808-28-K14-96-DW	28	K 14	-	96	54	36	13	280
DIN 808-32-K16-68-EW	32	K 16	68	-	24	37	16	424

DIN 808

DIN 808-needle bearing

Description	d1	d2 H7	s H10	l1	l2	l3	l4	t+1 max. assembly length of the shaft	⚖
DIN 808-32-K16-104-DW	32	K 16	-	-	10	24	37	16	417
DIN 808-32-K20-86-EW	32	K 20	-	86	-	31	38	24	313
DIN 808-32-K20-124-DW	32	K 20	-	-	124	31	38	24	458
DIN 808-36-K18-74-EW	36	K 18	-	74	-	28	40	17	373
DIN 808-36-K18-114-DW	36	K 18	-	-	114	28	40	17	558
DIN 808-42-K20-82-EW	42	K 20	-	82	-	37	46	18	559
DIN 808-42-K20-128-DW	42	K 20	-	-	128	37	46	18	889
DIN 808-42-K25-108-EW	42	K 25	-	108	-	30	48	31	703
DIN 808-42-K25-156-DW	42	K 25	-	-	156	30	48	31	1006
DIN 808-45-K22-95-EW	45	K 22	-	95	-	34	50	22	771
DIN 808-45-K22-145-DW	45	K 22	-	-	145	34	50	22	1117
DIN 808-50-K25-108-EW	50	K 25	-	108	-	43	55	26	1085
DIN 808-50-K25-163-DW	50	K 25	-	-	163	43	55	26	1590
DIN 808-50-K30-132-EW	50	K 30	-	132	-	37	56	38	1229
DIN 808-50-K30-188-DW	50	K 30	-	-	188	37	56	38	1714
DIN 808-58-K30-122-EW	58	K 30	-	122	-	41	68	29	1631
DIN 808-58-K30-190-DW	58	K 30	-	-	190	41	68	29	2531
DIN 808-58-K32-130-EW	58	K 32	-	130	-	54	68	33	1718
DIN 808-58-K32-198-DW	58	K 32	-	-	198	54	68	33	2541
DIN 808-70-K35-140-EW	70*	K 35	-	140	-	47.5	72	35	1920
DIN 808-70-K35-212-DW	70*	K 35	-	-	212	47.5	72	35	2760
DIN 808-22-V10-48-EW	22	-	V10*	48	-	54	26	12	91
DIN 808-22-V10-74-DW	22	-	V10*	-	74	54	26	12	141
DIN 808-25-V12-56-EW	25	-	V12*	56	-	61	30	13	91
DIN 808-25-V12-86-DW	25	-	V12*	-	86	61	30	13	208
DIN 808-28-V14-60-EW	28	-	V14*	60	-	70	36	13	174
DIN 808-28-V14-96-DW	28	-	V14*	-	96	70	36	13	287
DIN 808-32-V16-68-EW	32	-	V16*	68	-	24	37	16	174
DIN 808-32-V16-104-DW	32	-	V16*	-	104	24	37	16	414
DIN 808-36-V18-74-EW	36	-	V18*	74	-	28	40	17	380
DIN 808-36-V18-114-DW	36	-	V18*	-	114	28	40	17	414
DIN 808-42-V20-82-EW	42	-	V20*	82	-	37	46	18	572
DIN 808-42-V20-128-DW	42	-	V20*	-	128	37	46	18	620
DIN 808-45-V22-95-EW	45	-	V22*	95	-	34	50	22	740
DIN 808-45-V22-145-DW	45	-	V22*	-	145	34	50	22	810
DIN 808-50-V25-108-EW	50	-	V25*	108	-	43	55	26	1038
DIN 808-50-V25-163-DW	50	-	V25*	-	163	43	55	26	1518
DIN 808-58-V30-122-EW	58	-	V30*	122	-	41	68	29	1560
DIN 808-58-V30-190-DW	58	-	V30*	-	190	41	68	29	2040
DIN 808-70-V35-140-EW	70*	-	V35*	140	-	47.5	72	35	2540
DIN 808-70-V35-212-DW	70*	-	V35*	-	212	47.5	72	35	3000

\* not available from stock, requires a minimum order quantity