

Spherical / Dished Washers

Steel / Stainless Steel

SPECIFICATION

Version in Steel

Types

- Type **C**: Spherical seat washer
- Type **D**: Dished washer with $d_3 = d_2$
- Type **G**: Dished washer with $d_4 > d_2$ (enlarged outer diameter)

Type C / D

Case-hardening steel
Case-hardened
All round depth 0.2 to 0.4 mm
Hardness (550 + 100) HV 10

Type G

Heat-treated steel, tempered
Hardness (350 + 80) HV 30

Version in Stainless Steel

Types

Stainless steel AISI 303 **NI**
Type C / D / G
Not hardened

Stainless steel AISI 316 **A4**
Type C / D
Not hardened

INFORMATION

Spherical washers and dished washers DIN 6319 are used for clamping on non-parallel surfaces.

Thanks to the material used, the spherical washers and dished washers are generally suited for aggressive environmental conditions.

The dished washers type G with enlarged outside diameter are mainly used on elongated holes.

When utilizing hexagon nuts with spherical seating DIN 6330 (see page 962) type B the spherical washer is redundant.

ON REQUEST

Version in Steel

- Not hardened spherical washers
- Not hardened dished washers

Version in Stainless Steel

- Hardened spherical washers in stainless steel **NI**
- Hardened dished washers in stainless steel **NI**
- Stainless steel spherical washers, type G with $d_4 > d_2$ **A4** (enlarged outer diameter)

TECHNICAL INFORMATION

- ISO-Fundamental Tolerances (see page A21)
- Stainless Steel Characteristics (see page A26)

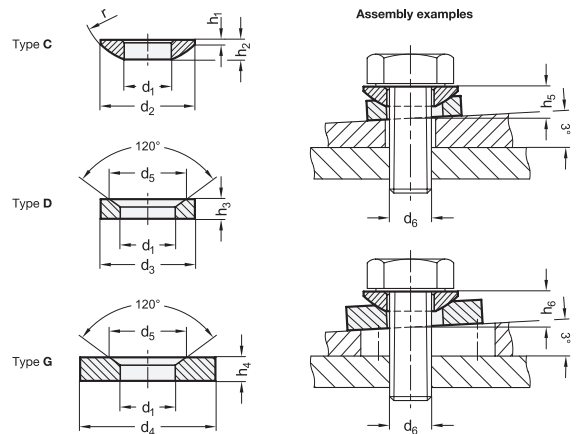

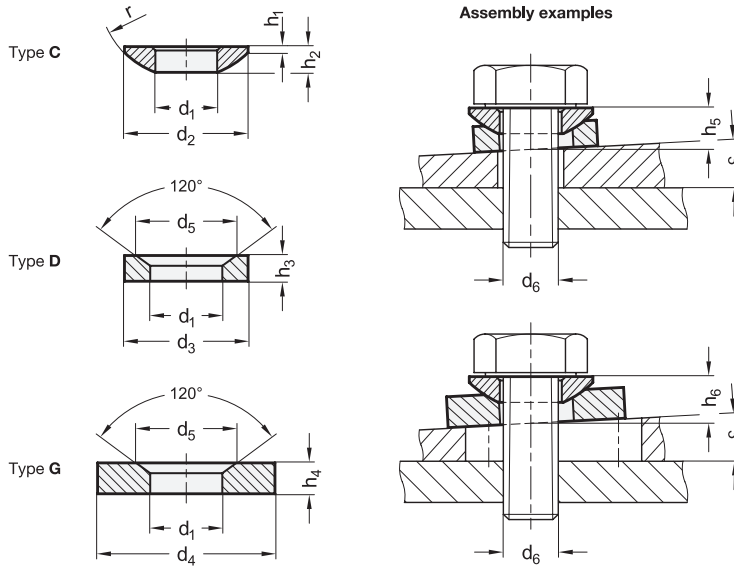

DIN 6319

Description	d1 H13	d2	d3	d4	d5	d6 Screw	h1	h2	h3	h4	h5 ≈	h6 ≈	r	Max. transferable static bolt force in kN	⚖
DIN 6319-6,4-C	6,4	12	-	-	-	M 6	0,7	2,3	-	-	4,2	-	9	9	1
DIN 6319-8,4-C	8,4	17	-	-	-	M 8	0,6	3,2	-	-	5,6	-	12	17	3
DIN 6319-10,5-C	10,5	21	-	-	-	M 10	0,8	4	-	-	6,5	-	15	26	6
DIN 6319-13-C	13	24	-	-	-	M 12	1,1	4,6	-	-	8	-	17	38	8
DIN 6319-15-C	15	28	-	-	-	M 14	1,2	5	-	-	8,5	-	22	53	10
DIN 6319-17-C	17	30	-	-	-	M 16	1,3	5,3	-	-	9,6	-	22	73	12
DIN 6319-21-C	21	36	-	-	-	M 20	2	6,3	-	-	11,7	-	27	117	22
DIN 6319-25-C	25	44	-	-	-	M 24	2,4	8,2	-	-	15,2	-	32	168	18
DIN 6319-31-C	31	56	-	-	-	M 30	3,6	11,2	-	-	19,2	-	41	269	100
DIN 6319-37-C	37	68	-	-	-	M 36	4,6	14	-	-	23,5	-	50	394	180
DIN 6319-43-C	43	78	-	-	-	M 42	6,5	17	-	-	29	-	58	542	318
DIN 6319-50-C	50	92	-	-	-	M 48	8	21	-	-	35,5	-	67	714	540
DIN 6319-7,1-D	7,1	-	12	-	11	M 6	-	-	2,8	-	4,2	-	-	9	2
DIN 6319-9,6-D	9,6	-	17	-	14,5	M 8	-	-	3,5	-	5,6	-	-	17	4
DIN 6319-12-D	12	-	21	-	18,5	M 10	-	-	4,2	-	6,5	-	-	26	6
DIN 6319-14,2-D	14,2	-	24	-	20	M 12	-	-	5	-	8	-	-	38	10
DIN 6319-16,5-D	16,5	-	28	-	24,8	M 14	-	-	5,6	-	8,5	-	-	53	14
DIN 6319-19-D	19	-	30	-	26	M 16	-	-	6,2	-	9,6	-	-	73	17
DIN 6319-23,2-D	23,2	-	36	-	31	M 20	-	-	7,5	-	11,7	-	-	117	32
DIN 6319-28-D	28	-	44	-	37	M 24	-	-	9,5	-	15,2	-	-	168	61
DIN 6319-35-D	35	-	56	-	49	M 30	-	-	12	-	19,2	-	-	269	120
DIN 6319-42-D	42	-	68	-	60	M 36	-	-	15	-	23,5	-	-	394	250
DIN 6319-49-D	49	-	78	-	70	M 42	-	-	18	-	29	-	-	542	360
DIN 6319-56-D	56	-	92	-	82	M 48	-	-	22	-	35,5	-	-	714	640
DIN 6319-7,1-G	7,1	-	-	17	11	M 6	-	-	-	4	-	5,4	-	9	6
DIN 6319-9,6-G	9,6	-	-	24	14,5	M 8	-	-	-	5	-	7,1	-	17	15
DIN 6319-12-G	12	-	-	30	18,5	M 10	-	-	-	5	-	7,3	-	26	20
DIN 6319-14,2-G	14,2	-	-	36	20	M 12	-	-	-	6	-	9	-	38	39
DIN 6319-19-G	19	-	-	44	26	M 16	-	-	-	7	-	10,4	-	53	65
DIN 6319-23,2-G	23,2	-	-	50	31	M 20	-	-	-	8	-	12,2	-	73	90
DIN 6319-28-G	28	-	-	60	37	M 24	-	-	-	10	-	15,7	-	117	162
DIN 6319-35-G	35	-	-	68	49	M 30	-	-	-	12	-	19,7	-	168	235
DIN 6319-16,5-G	16,5	-	-	40	24,8	M 14	-	-	-	6	-	9,5	-	269	45



9

Machine elements

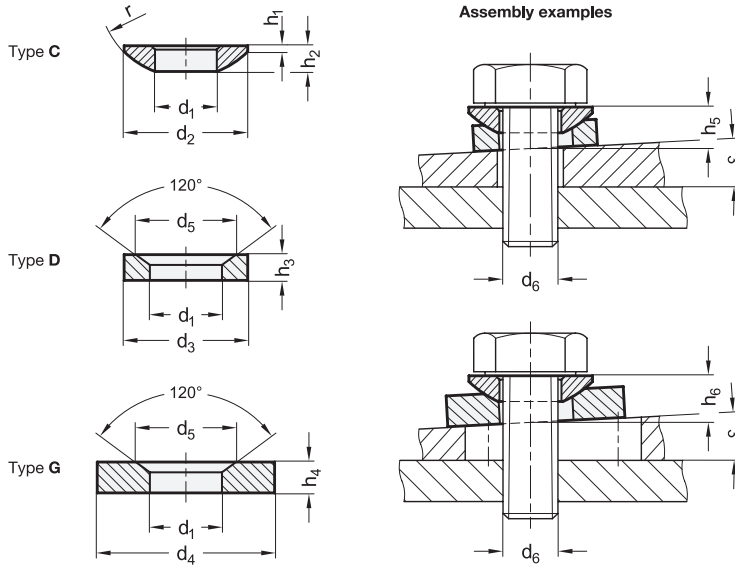

DIN 6319-NI

STAINLESS STEEL

Description	d1 H13	d2	d3	d4	d5	d6 Screw	h1	h2	h3	h4	h5 ≈	h6 ≈	r	Max. transferable static bolt force in kN	⚖️
DIN 6319-6,4-C-NI	6.4	12	-	-	-	M 6	0.7	2.3	-	-	4.2	-	9	6	3
DIN 6319-8,4-C-NI	8.4	17	-	-	-	M 8	0.6	3.2	-	-	5.6	-	12	10	4
DIN 6319-10,5-C-NI	10.5	21	-	-	-	M 10	0.8	4	-	-	6.5	-	15	17	9
DIN 6319-13-C-NI	13	24	-	-	-	M 12	1.1	4.6	-	-	8	-	17	25	8
DIN 6319-15-C-NI	15	28	-	-	-	M 14	1.2	5	-	-	8.5	-	22	34	11
DIN 6319-17-C-NI	17	30	-	-	-	M 16	1.3	5.3	-	-	9.6	-	22	47	10
DIN 6319-21-C-NI	21	36	-	-	-	M 20	2	6.3	-	-	11.7	-	27	73	22
DIN 6319-25-C-NI	25	44	-	-	-	M 24	2.4	8.2	-	-	15.2	-	32	105	43
DIN 6319-31-C-NI	31	56	-	-	-	M 30	3.6	11.2	-	-	19.2	-	41	168	110
DIN 6319-37-C-NI	37	68	-	-	-	M 36	4.6	14	-	-	23.5	-	50	245	190
DIN 6319-43-C-NI	43	78	-	-	-	M 42	6.5	17	-	-	29	-	58	336	305
DIN 6319-50-C-NI	50	92	-	-	-	M 48	8	21	-	-	35.5	-	67	441	540
DIN 6319-7,1-D-NI	7.1	-	12	-	11	M 6	-	-	2.8	-	4.2	-	-	6	4
DIN 6319-9,6-D-NI	9.6	-	17	-	14.5	M 8	-	-	3.5	-	5.6	-	-	10	5
DIN 6319-12-D-NI	12	-	21	-	18.5	M 10	-	-	4.2	-	6.5	-	-	17	6
DIN 6319-14,2-D-NI	14.2	-	24	-	20	M 12	-	-	5	-	8	-	-	25	10
DIN 6319-19-D-NI	19	-	30	-	26	M 16	-	-	6.2	-	9.6	-	-	34	18
DIN 6319-23,2-D-NI	23.2	-	36	-	31	M 20	-	-	7.5	-	11.7	-	-	47	33
DIN 6319-28-D-NI	28	-	44	-	37	M 24	-	-	9.5	-	15.2	-	-	73	61
DIN 6319-35-D-NI	35	-	56	-	49	M 30	-	-	12	-	19.2	-	-	105	110
DIN 6319-42-D-NI	42	-	68	-	60	M 36	-	-	15	-	23.5	-	-	168	230
DIN 6319-49-D-NI	49	-	78	-	70	M 42	-	-	18	-	29	-	-	245	360
DIN 6319-56-D-NI	56	-	92	-	82	M 48	-	-	22	-	35.5	-	-	336	640
DIN 6319-16,5-D-NI	16.5	-	28	-	24.8	M 14	-	-	5.6	-	8.5	-	-	441	15
DIN 6319-7,1-G-NI	7.1	-	-	17	11	M 6	-	-	-	4	-	5.4	-	6	6
DIN 6319-9,6-G-NI	9.6	-	-	24	14.5	M 8	-	-	-	5	-	7.1	-	10	14
DIN 6319-12-G-NI	12	-	-	30	18.5	M 10	-	-	-	5	-	7.3	-	17	21
DIN 6319-14,2-G-NI	14.2	-	-	36	20	M 12	-	-	-	6	-	9	-	25	38
DIN 6319-16,5-G-NI	16.5	-	-	40	24.8	M 14	-	-	-	6	-	9.5	-	34	47
DIN 6319-19-G-NI	19	-	-	44	26	M 16	-	-	-	7	-	10.4	-	47	64
DIN 6319-23,2-G-NI	23.2	-	-	50	31	M 20	-	-	-	8	-	12.2	-	73	92
DIN 6319-28-G-NI	28	-	-	60	37	M 24	-	-	-	10	-	15.7	-	105	165
DIN 6319-35-G-NI	35	-	-	68	49	M 30	-	-	-	12	-	19.7	-	168	190

Machine elements 9

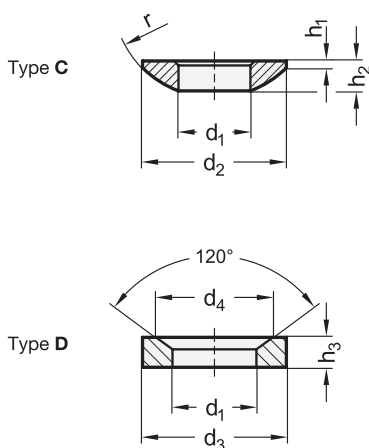

Assembly examples

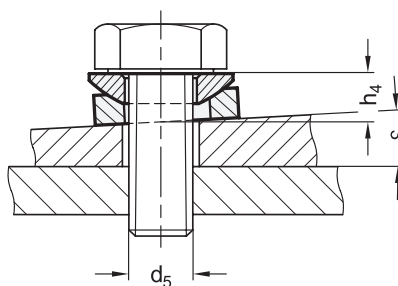

DIN 6319-A4

STAINLESS STEEL

Description	d1 H13	d2	d3	d4	d5 Screw	h1	h2	h3	h4 ≈	r	Max. transferable static bolt force in kN	⚖
DIN 6319-6,4-C-A4	6.4	12	-	-	M 6	0.7	2.3	-	4.2	9	6	2
DIN 6319-8,4-C-A4	8.4	17	-	-	M 8	0.6	3.2	-	5.6	12	10	3
DIN 6319-10,5-C-A4	10.5	21	-	-	M 10	0.8	4	-	6.5	15	17	7
DIN 6319-13-C-A4	13	24	-	-	M 12	1.1	4.6	-	8	17	25	8
DIN 6319-15-C-A4	15	28	-	-	M 14	1.2	5	-	8.5	22	34	11
DIN 6319-17-C-A4	17	30	-	-	M 16	1.3	5.3	-	9.6	22	47	13
DIN 6319-21-C-A4	21	36	-	-	M 20	2	6.3	-	11.7	27	73	22
DIN 6319-25-C-A4	25	44	-	-	M 24	2.4	8.2	-	15.2	32	105	43
DIN 6319-31-C-A4	31	56	-	-	M 30	3.6	11.2	-	19.2	41	168	110
DIN 6319-7,1-D-A4	7.1	-	12	11	M 6	-	-	2.8	4.2	-	6	2
DIN 6319-9,6-D-A4	9.6	-	17	14.5	M 8	-	-	3.5	5.6	-	10	4
DIN 6319-12-D-A4	12	-	21	18.5	M 10	-	-	4.2	6.5	-	17	7
DIN 6319-14,2-D-A4	14.2	-	24	20	M 12	-	-	5	8	-	25	10
DIN 6319-16,5-D-A4	16.5	-	28	24.8	M 14	-	-	5.6	8.5	-	34	16
DIN 6319-19-D-A4	19	-	30	26	M 16	-	-	6.2	9.6	-	47	18
DIN 6319-23,2-D-A4	23.2	-	36	31	M 20	-	-	7.5	11.7	-	73	31
DIN 6319-28-D-A4	28	-	44	37	M 24	-	-	9.5	15.2	-	105	61
DIN 6319-35-D-A4	35	-	56	49	M 30	-	-	12	19.2	-	168	120



9

Machine elements