

# DIN 6306

Tommy screws

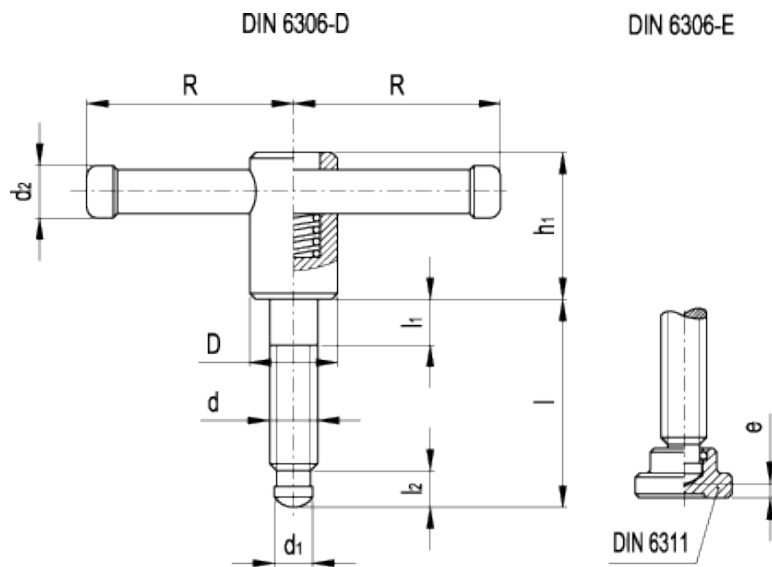

## technical informations

### Material

Black-oxide steel body and hardened steel thrust point.

- Execution D: without thrust pad.
- Execution E: with [DIN 6311](#) thrust pad.

### Bar end caps

Light grey acetal resin based (POM) technopolymer.

### Features and applications

The thrust point of DIN 6306 tommy screws is designed to be used with or without the thrust pad for clamping. The snap ring is a simple and quick method to connect the thrust pad to the tommy screw.

Thanks to the inner spring it can be moved to any position and maintained in the right position by it.

The end caps are pressed onto the bar and thus can limit its movement. They can also be supplied separately should the bar be plated first.

Standard Elements	Main dimensions										Weight
Description	D	R	h <sub>1</sub>	d	d <sub>1</sub> h <sub>11</sub>	d <sub>2</sub>	l	l <sub>1</sub>	l <sub>2</sub>	e	g
DIN 6306-M10-40-D	18	40	32	M10	8	8	40	10	8.2	-	86
DIN 6306-M10-40-E	18	40	32	M10	8	8	40	10	8.2	3.6	103
DIN 6306-M10-50-D	18	40	32	M10	8	8	50	10	8.2	-	92
DIN 6306-M10-50-E	18	40	32	M10	8	8	50	10	8.2	3.6	109
DIN 6306-M12-50-D	20	50	35	M12	8	10	50	10	8.6	-	144
DIN 6306-M12-50-E	20	50	35	M12	8	10	50	10	8.6	4.5	177
DIN 6306-M12-60-D	20	50	35	M12	8	10	60	10	8.6	-	151
DIN 6306-M12-60-E	20	50	35	M12	8	10	60	10	8.6	4.5	184
DIN 6306-M16-55-D	24	60	40	M16	12	13	55	10	10.6	-	287
DIN 6306-M16-55-E	24	60	40	M16	12	13	55	10	10.6	5.3	346
DIN 6306-M16-70-D	24	60	40	M16	12	13	70	10	10.6	-	308
DIN 6306-M16-70-E	24	60	40	M16	12	13	70	10	10.6	5.3	367
DIN 6306-M16-90-D	24	60	40	M16	12	13	90	10	10.6	-	330
DIN 6306-M16-90-E	24	60	40	M16	12	13	90	10	10.6	5.3	389
DIN 6306-M20-55-D	30	70	45	M20	15.5	16	55	10	12.4	-	502
DIN 6306-M20-55-E	30	70	45	M20	15.5	16	55	10	12.4	5.6	607
DIN 6306-M20-70-D	30	70	45	M20	15.5	16	70	10	12.4	-	532
DIN 6306-M20-70-E	30	70	45	M20	15.5	16	70	10	12.4	5.6	637
DIN 6306-M20-90-D	30	70	45	M20	15.5	16	90	10	12.4	-	572
DIN 6306-M20-90-E	30	70	45	M20	15.5	16	90	10	12.4	5.6	677



STANDARD MACHINE ELEMENTS WORLDWIDE