

DIN 3670

Solid handwheels

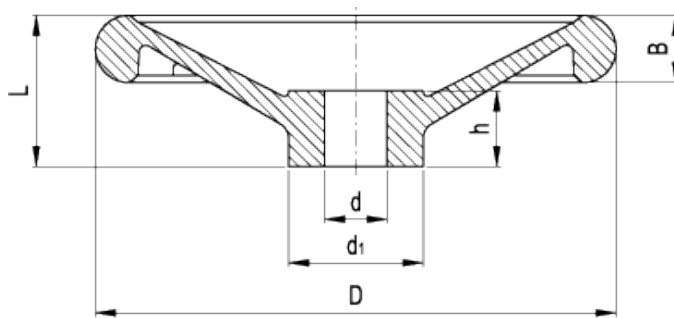

technical informations

Material

Aluminium, fine sandblasted matte surface, turned and mirror-polished rim.

Assembly

- Version B: hub with H7 tolerance plain hole.
 - Version K: hub with H7 reamed hole and keyway in compliance with [DIN 6885/1 P9 tolerance](#).
- For fixing DIN 3670 on shafts by a grub screw see [Technical Data](#).

Accessories on request

Axial retaining washer type [GN 184](#)

Technical data

Axial and radial runout lower than 0.4.

Order information

DIN 3670 handwheels can be supplied only without handle.

Standard Elements	Main dimensions				Bore		Weight
	Description	D	d ₁	B	L	d _{H7}	
DIN 3670-80-B10	80	26	14	29	10	16	128
DIN 3670-80-B12	80	26	14	29	12	16	127
DIN 3670-80-K10	80	26	14	29	10	16	126
DIN 3670-80-K12	80	26	14	29	12	16	125
DIN 3670-100-B10	100	28	15	33	10	17	188
DIN 3670-100-B12	100	28	15	33	12	17	185
DIN 3670-100-K10	100	28	15	33	10	17	187
DIN 3670-100-K12	100	28	15	33	12	17	184
DIN 3670-125-B12	125	31	16	36	12	18	306
DIN 3670-125-B14	125	31	16	36	14	18	304
DIN 3670-125-K12	125	31	16	36	12	18	304
DIN 3670-125-K14	125	31	16	36	14	18	302
DIN 3670-160-B14	160	36	18	40	14	20	514
DIN 3670-160-B16	160	36	18	40	16	20	508
DIN 3670-160-K14	160	36	18	40	14	20	511
DIN 3670-160-K16	160	36	18	40	16	20	505
DIN 3670-200-B18	200	42	22	45	18	24	943
DIN 3670-200-B20	200	42	22	45	20	24	938
DIN 3670-200-B22	200	42	22	45	22	24	933
DIN 3670-200-K18	200	42	22	45	18	24	940
DIN 3670-200-K20	200	42	22	45	20	24	935
DIN 3670-200-K22	200	42	22	45	22	24	930
DIN 3670-250-B22	250	48	26	50	22	28	1608
DIN 3670-250-B24	250	48	26	50	24	28	1596
DIN 3670-250-B26	250	48	26	50	26	28	1584
DIN 3670-250-K22	250	48	26	50	22	28	1604
DIN 3670-250-K24	250	48	26	50	24	28	1592
DIN 3670-250-K26	250	48	26	50	26	28	1580
DIN 3670-315-B26	315	56	28	56	26	33	2695
DIN 3670-315-B28	315	56	28	56	28	33	2689
DIN 3670-315-B30	315	56	28	56	30	33	2683
DIN 3670-315-K26	315	56	28	56	26	33	2690
DIN 3670-315-K28	315	56	28	56	28	33	2684
DIN 3670-315-K30	315	56	28	56	30	33	2678
DIN 3670-400-B30	400	65	32	63	30	38	4545
DIN 3670-400-B32	400	65	32	63	32	38	4342
DIN 3670-400-K30	400	65	32	63	30	38	4535
DIN 3670-400-K32	400	65	32	63	32	38	4332

ELESA and GANTER models all rights reserved in accordance with the law. Always mention the source when reproducing our drawings.

STANDARD MACHINE ELEMENTS WORLDWIDE