

Ball Knobs

Plastic / Steel / Aluminium / Stainless Steel

SPECIFICATION

Version in Plastic

Types

- Type **C**: With tapped hole (no bushing)
- Type **E**: With tapped bushing

Plastic **KU**

Duroplast (Phenolic PF)

- Flash removed and polished
- Black (standard color)
- Red **RT**, similar RAL 3003: add RT on order code

Bushing (Type E)

- Steel, zinc plated (standard)
- Brass **MS** add MS on order code (only in black version)

Plastic **KT**

Technopolymer (Polyamide PA)

- Shock resistant
- Black, matte
- Red **RT**, similar RAL 3003: add RT on order code

Version in Steel

Types

- Type **C**: With tapped hole
- Type **K**: With plain hole H7

Steel **ST**

Polished

Version in Aluminium

Types

- Type **C**: With tapped hole
- Type **K**: With plain hole H7

Aluminium **AL**

Polished

Version in Stainless Steel

Types

- Type **C**: With tapped hole
- Type **K**: With plain hole H7

Stainless Steel AISI 303 **NI**

Matte shot-blasted

Version in Plastic (Press on type)

Types

- Type **L**: With tolerance ring
- Type **M**: With tapered bore

Type L

Plastic **KU**

Duroplast (Phenolic PF)

Black, shiny finish

Tolerance ring

Spring steel

Type M

Plastic **KT**

Technopolymer (Polyamide PA)

- Shock resistant
- Black, matte finish
- Red version



INFORMATION

When ball knobs DIN 319 (Press on type) type L and M are used the shaft does not require a thread.

During mounting, easy blows with a soft hammer are sufficient to drive the knob into place, the shaft end should be slightly rounded or chamfered (30°).

Before the assembly of the knobs, type L the tolerance ring is to be inserted into the drilling. Further it is to be noted that the button is put on perpendicular and / or axially parallel. Otherwise the knob may break.

Type M ball knobs are a cheaper solution, however, the pulling off force is less predictable.

Ball knobs DIN 319 made of steel, aluminum and stainless steel are not on the official DIN standard sheet.

ON REQUEST

- Red version

TECHNICAL INFORMATION

- ISO-Fundamental Tolerances (see page A21)
- Stainless Steel characteristics (see page A26)
- Plastic characteristics - Duroplast (see page A2)
- Plastic characteristics - Technopolymer (see page A32)

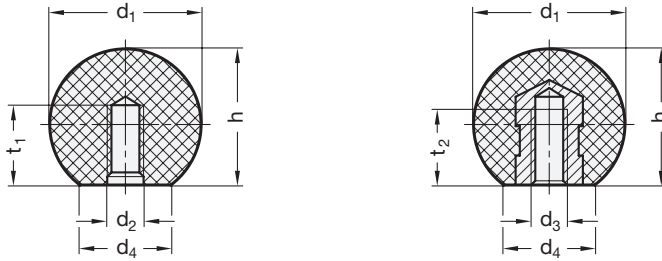

DIN 319-KU

Descripción	d1	d2	d3	d4 ≈	h ≈	t1 min.	t2 min.	△
DIN 319-KU-10-M3-C	10	M 3	-	5	9.3	5	-	1
DIN 319-KU-12-M4-C	12	M 4	-	6	11.2	6	-	1
DIN 319-KU-16-M4-C	16	M 4	-	8	15	6	6	2
DIN 319-KU-16-M5-C	16	M 5	-	8	15	6	6	2
DIN 319-KU-20-M5-C	20	M 5	-	12	18	7.5	7.5	5
DIN 319-KU-20-M6-C	20	M 6	-	12	18	7.5	7.5	5
DIN 319-KU-25-M5-C	25	M 5	-	15	22.5	9	9	10
DIN 319-KU-25-M6-C	25	M 6	-	15	22.5	9	9	8
DIN 319-KU-25-M8-C	25	M 8	-	15	22.5	9	9	9
DIN 319-KU-30-M8-C	30	M 8	-	15	28	12	-	16
DIN 319-KU-32-M6-C	32	M 6	-	18	29	12	12	21
DIN 319-KU-32-M8-C	32	M 8	-	18	29	12	12	20
DIN 319-KU-32-M10-C	32	M 10	-	18	29	12	12	20
DIN 319-KU-35-M10-C	35	M 10	-	18	32.5	15	-	27
DIN 319-KU-40-M8-C	40	M 8	-	22	37	15	15	40
DIN 319-KU-40-M10-C	40	M 10	-	22	37	15	15	38
DIN 319-KU-40-M12-C	40	M 12	-	22	37	15	15	38
DIN 319-KU-50-M12-C	50	M 12	-	28	46	18	18	87
DIN 319-KU-20-M5-E	20	-	M 5	12	18	7.5	7.5	7
DIN 319-KU-25-M6-E	25	-	M 6	15	22.5	9	9	12
DIN 319-KU-25-M8-E	25	-	M 8	15	22.5	9	9	16
DIN 319-KU-32-M8-E	32	-	M 8	18	29	12	12	25
DIN 319-KU-40-M10-E	40	-	M 10	22	37	15	15	50
DIN 319-KU-50-M12-E	50	-	M 12	28	46	18	18	110

DIN 319-KT

Descripción	d1	d2	d3	d4 ≈	h ≈	t1 min.	t2 min.	△
DIN 319-KT-16-M4-C	16	M 4	-	8	15	6	6	3
DIN 319-KT-16-M5-C	16	M 5	-	8	15	6	6	2
DIN 319-KT-20-M5-C	20	M 5	-	12	18	7.5	7.5	5
DIN 319-KT-20-M6-C	20	M 6	-	12	18	7.5	7.5	5
DIN 319-KT-25-M6-C	25	M 6	-	15	22.5	9	9	10
DIN 319-KT-25-M8-C	25	M 8	-	15	22.5	9	9	10
DIN 319-KT-32-M8-C	32	M 8	-	18	29	12	12	20
DIN 319-KT-32-M10-C	32	M 10	-	18	29	12	12	21
DIN 319-KT-40-M10-C	40	M 10	-	22	37	15	15	40
DIN 319-KT-40-M12-C	40	M 12	-	22	37	15	15	40
DIN 319-KT-16-M4-E	16	-	M 4	8	15	6	6	3
DIN 319-KT-16-M5-E	16	-	M 5	8	15	6	6	4
DIN 319-KT-20-M5-E	20	-	M 5	12	18	7.5	7.5	8
DIN 319-KT-20-M6-E	20	-	M 6	12	18	7.5	7.5	8
DIN 319-KT-25-M6-E	25	-	M 6	15	22.5	9	9	14
DIN 319-KT-25-M8-E	25	-	M 8	15	22.5	9	9	15
DIN 319-KT-32-M8-E	32	-	M 8	18	29	12	12	25
DIN 319-KT-32-M10-E	32	-	M 10	18	29	12	12	28
DIN 319-KT-40-M10-E	40	-	M 10	22	37	15	15	54
DIN 319-KT-40-M12-E	40	-	M 12	22	37	15	15	57



5

Fixed and Revolving Handles

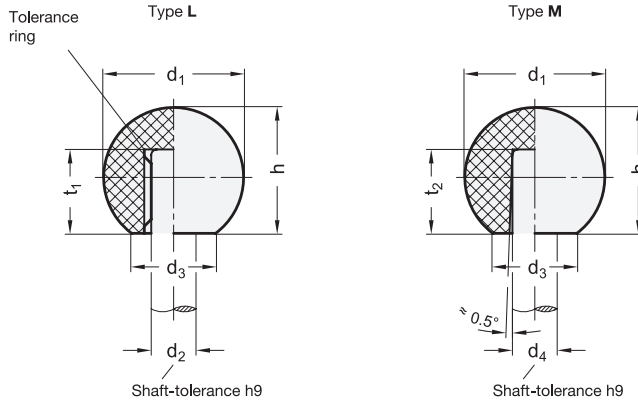

DIN 319-KU modelo a Presión

Descripción	d1	d2	t1	d3 ≈	h ≈	Δ
DIN 319-KU-16-B4-L	16	B 4	11	8	15	2
DIN 319-KU-20-B5-L	20	B 5	13	12	18	5
DIN 319-KU-25-B6-L	25	B 6	16	15	22.5	9
DIN 319-KU-25-B8-L	25	B 8	15	15	22.5	9
DIN 319-KU-25-B10-L	25	B 10	15	15	22.5	9
DIN 319-KU-32-B8-L	32	B 8	15	18	29	21
DIN 319-KU-32-B10-L	32	B 10	20	18	29	20
DIN 319-KU-32-B12-L	32	B 12	20	18	29	19
DIN 319-KU-40-B10-L	40	B 10	25	22	37	39
DIN 319-KU-40-B12-L	40	B 12	23	22	37	38
DIN 319-KU-50-B12-L	50	B 12	20	28	46	86
DIN 319-KU-50-B16-L	50	B 16	23	28	46	83

DIN 319-KT modelo a Presión

Descripción	d1	d4	t2	d3 ≈	h ≈	Δ
DIN 319-KT-16-B4-M	16	B 4	9	8	15	3
DIN 319-KT-16-B5-M	16	B 5	9	8	15	5
DIN 319-KT-20-B5-M	20	B 5	12	12	18	5
DIN 319-KT-20-B6-M	20	B 6	12	12	18	5
DIN 319-KT-25-B6-M	25	B 6	16	15	22.5	10
DIN 319-KT-25-B8-M	25	B 8	16	15	22.5	10
DIN 319-KT-32-B8-M	32	B 8	17	18	29	20
DIN 319-KT-32-B10-M	32	B 10	17	18	29	21
DIN 319-KT-40-B10-M	40	B 10	22	22	37	43
DIN 319-KT-40-B12-M	40	B 12	22	22	37	40

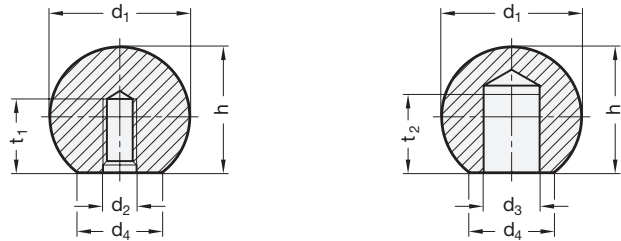

* Complete with material of the Ball knobs (ST, AL or NI)

ST	AL	NI
Steel	Aluminium	Stainless Steel

DIN 319

STAINLESS STEEL

Descripción	d1	d2	d3 H7	d4 ≈	h ≈	t1 min.	t2 min.	Δ
DIN 319-*-16-M4-C	16	M 4	-	8	15	7	9	7
DIN 319-*-20-M5-C	20	M 5	-	12	18	9	11	11
DIN 319-*-25-M6-C	25	M 6	-	15	22.5	11	14	22
DIN 319-*-32-M8-C	32	M 8	-	18	29	14.5	17	41
DIN 319-*-40-M10-C	40	M 10	-	22	37	18	22	80
DIN 319-*-50-M12-C	50**	M 12	-	27	46	21	28	173
DIN 319-*-16-B6-K	16	-	B 6	8	15	7	9	6
DIN 319-*-20-B8-K	20	-	B 8	12	18	9	11	10
DIN 319-*-25-B10-K	25	-	B 10	15	22.5	11	14	18
DIN 319-*-32-B12-K	32	-	B 12	18	29	14.5	17	41
DIN 319-*-40-B16-K	40	-	B 16	22	37	18	22	75
DIN 319-*-50-B20-K	50	-	B 20	27	46	21	28	146

** Este tamaño solo está disponible en acero e aluminio

Peso del tipo Aluminio