

**HANDLE AND STATOR**

Glossy chrome-plated zinc alloy.

**ROTOR**

Chrome-plated zinc alloy.

**FRONT PLATE**

Stainless steel.

**NUT**

M22x1.5 in zinc-plated zinc-alloy.

**SPRING WASHER**

Black-oxide steel.

**WASHER**

Zinc-plated steel.

**CLOSING LEVERS**

Zinc-plated steel flat and two-point closing lever, thickness 3 mm.

**SCREW**

M7x10 Zinc-plated steel.

**TWO KEYS**

Nickel-plated brass, removable in two positions at 180°.

**STANDARD EXECUTIONS**

Handle rotation by 90° clockwise (right):

- **CSM.:** lock with 400 different combinations. Each lock has a couple of keys with different combination.
- **CSMU.:** lock with one combination. All locks have the same combination and can be opened with the same key.

Handle rotation by 90° anticlockwise (left):

- **CSM-S:** lock with 400 different combinations. Each lock has a couple of keys with different combination.
- **CSMU-S:** lock with one combination. All locks have the same combination and can be opened with the same key.

**SPECIAL EXECUTIONS AND ACCESSORIES**

- Closing levers in other dimensions.
- Brass threaded extension (code 421140 C.PQ M7/53) and flat assembly lever (code 421145 LEVETTA PIANA 7x7) for prolonged positioning of the closing ledge



Drilling template

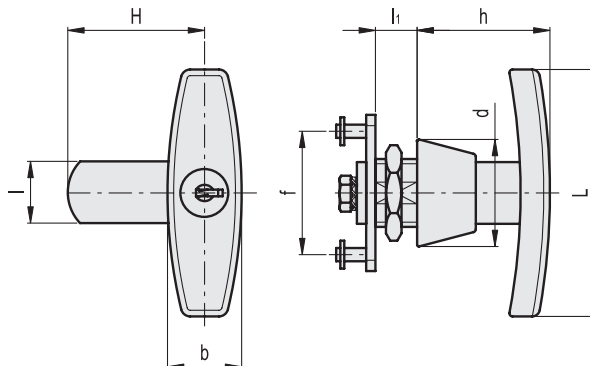
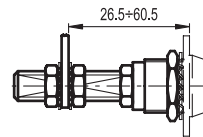
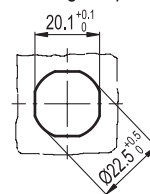

Code	Description	H	L	l	l1	b	h	d	f	Δ
421511	CSM.50	50	80	20	13.5	24	43.5	35	42	240
421513	CSMU.50	50	80	20	13.5	24	43.5	35	42	240
421512	CSM.50-S	50	80	20	13.5	24	43.5	35	42	240
421514	CSMU-50-S	50	80	20	13.5	24	43.5	35	42	240

