

MATERIAL

Glass-fibre reinforced polyamide (PA) SUPER-technopolymer body, black colour, matte finish.

SHOCK ABSORBER

Silicon oil base

STANDARD EXECUTIONS

Pass-through holes for M6 cylindrical head screws.

- **CFAM-O-NC:** for applications with horizontal axis, soft return on closing.
- **CFAM-O-NO:** for applications with horizontal axis, soft return on opening.
- **CFAM-V-NC:** for applications with vertical axis, soft return on closing.
- **CFAM-V-NO:** for applications with vertical axis, soft return on opening.

Suffix to indicate the shock absorber torque value:

- 080: final damping torque 0.8 Nm.
- 300: final damping torque 3.0 Nm.

ROTATION ANGLE (APPROXIMATE VALUE)

Max 110° (0° and +110° being 0° the condition where the two interconnected surfaces are on the same plane).

The hinge can also allow an extra -5° to compensate for any misalignments of the frames.

Do not exceed the rotation angle limit so as not to prejudice the hinge mechanical performance.

DAMPING ANGLE

Damping occurs only in one direction depending on the chosen execution (NO or NC) as indicated in the drawings.

Allow the hinge to close and open freely, without forcing it.

FEATURES AND PERFORMANCES

The CFAM hinge is used to cushion the re-closing or re-opening of doors with vertical axis (CFAM-V) or of hatches with horizontal axis (CFAM-O) by means of the shock absorber.

The damping torque varies progressively with the rotation of the hinge, from a minimum to a maximum value as indicated in the drawing.

In specific fatigue stress tests, the damper has exceeded 20,000 / 30,000 cycles while maintaining the nominal value of the damping torque.



ELESA Original design

SELECTION GUIDE

Based on the torque generated by the weight of the door or by the hinge with return spring, a configuration of hinges is suggested that allows the door to be softly closed in about 5 seconds.

These values are indicative and are intended as a guideline for preliminary sizing.

It is recommended to check the theoretical values with practical operational tests on the intended site and application.

It is recommended to use the CFAM-V hinge in combination with the hinges for automatic return. CFMR (see page -).

In this way the ideal coupling is obtained for the automatic and soft closing of a hatch.

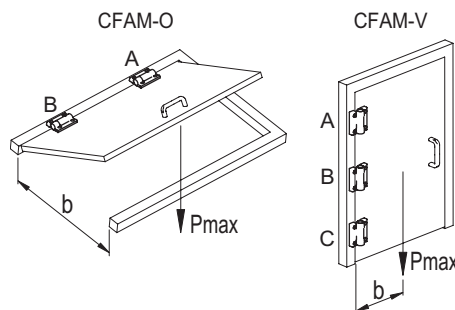
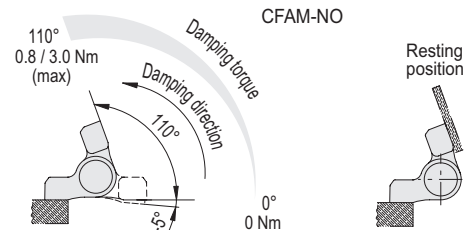
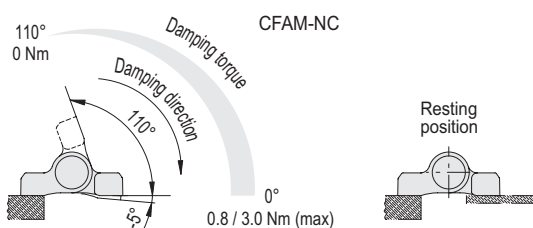

Hinges to be used for horizontal axis configuration (CFAM-O)

Torque Cmax	A	B
0.8 Nm	CFAM-O-080	CFMR-NS
2 Nm	CFAM-O-080	CFAM-O-080
2.5 Nm	CFAM-O-300	CFMR-NS
4 Nm	CFAM-O-080	CFAM-O-300
5.5 Nm	CFAM-O-300	CFAM-O-300

Hinges to be used for vertical axis configuration (CFAM-V)

Torque Cmax	A	B	C
0 + 6 Nm	CFMR-100	CFAM-V-080	CFMR-100

Cmax maximum torque (Cmax [Nm] = Pmax [N] x b [m]).

NOTE: arm b depends on the centre of gravity and on the coaxiality of the hinges.

Resistance tests	Axial Stress	Radial Stress	90° Angled Stress
Description	Max limit static load Sa [N]	Max limit static load Sr [N]	Max limit static load S90 [N]
CFAM.	2100	2400	2400

The max static load is the value above which the material may break thus prejudicing the hinge functionality. Obviously, a suitable factor, according to the importance and the safety level of the specific application must be applied to this value.

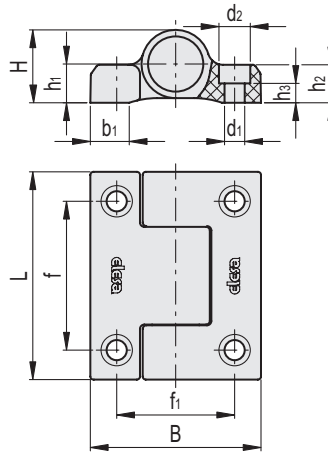

CFAM-O-NC

Code	Description	L	B	d1	d2	h2	f	f1	H	h1	h3	b1	C# [Nm]	⚖
422481	CFAM.67-O-NC-080	67	55	6.5	10	12.5	48	38	24	12.5	6.3	15	4	60
422483	CFAM.67-O-NC-300	67	55	6.5	10	12.5	48	38	24	12.5	6.3	15	4	60

CFAM-O-NO

Code	Description	L	B	d1	d2	h2	f	f1	H	h1	h3	b1	C# [Nm]	⚖
422485	CFAM.67-O-NO-080	67	55	6.5	10	12.5	48	38	24	12.5	6.3	15	4	60
422487	CFAM.67-O-NO-300	67	55	6.5	10	12.5	48	38	24	12.5	6.3	15	4	60

CFAM-V-NC

Code	Description	L	B	d1	d2	h2	f	f1	H	h1	h3	b1	C# [Nm]	⚖
422491	CFAM.67-V-NC-080	67	55	6.5	10	12.5	48	38	24	12.5	6.3	15	4	60

CFMR-V-NO

Code	Description	L	B	d1	d2	h2	f	f1	H	h1	h3	b1	C# [Nm]	⚖
422495	CFAM.67-V-NO-080	67	55	6.5	10	12.5	48	38	24	12.5	6.3	15	4	60

Maximum tightening torque for screw assembly.

