

PHYSICAL AND MECHANICAL NOTES:

A. PRODUCT DESCRIPTION: MAGNETICALLY OPERATED SINGLE-POLE DOUBLE-THROW PROXIMITY SWITCH WITH INTEGRATED LEDS.

B. MATERIAL

- HOUSING: POLYCARBONATE, CLEAR, UL94 V-0 RATED
- BASE PLATE: PC/ABS, BLACK, UL94 V-0 RATED
- PRESSURE SENSITIVE ADHESIVE: ACRYLIC ADHESIVE WITH FOAM CORE
- WIRE: UL 1007, 26AWG (7/32), PVC INSULATION

C. CONNECTOR TYPE

- CONNECTOR: DUAL ROW, 6 POSITION, 3mm: MOLEX P/N: 43025-0600 OR APPROVED ALTERNATE
- CONTACT: FEMALE CRIMP TERMINAL (SOCKET) MOLEX P/N: 43030-0004 OR APPROVED ALTERNATE
- MATING CONNECTOR NOT SUPPLIED
- MATING CONNECTOR: MOLEX P/N: 43020-0601
- MATING CONTACT: MOLEX P/N: 46235-0001

D. ENVIRONMENTAL

- ALL ITEMS COMPLY WITH RoHS DIRECTIVE AND REACH REGULATION
- IP67 RATED (NOT INCLUDING CONNECTOR)

REVISION HISTORY			
REV	DATE	BY	DESCRIPTION
C	16DEC2021	ZAM/MLL	PRN: P2021-1200

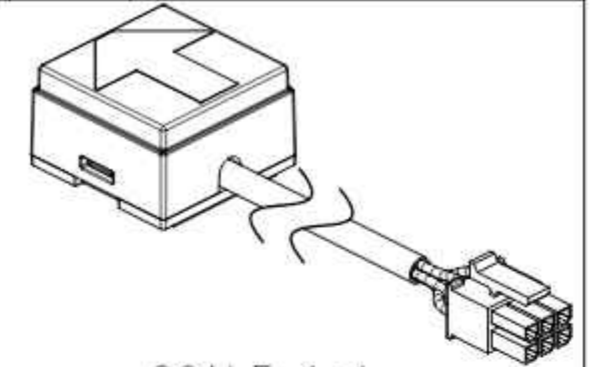

SCALE 1:1

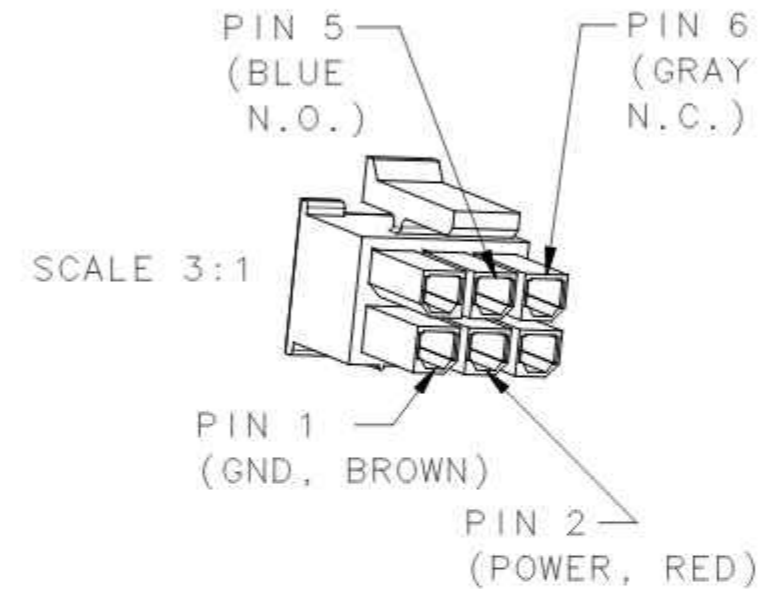

SCALE 3:1

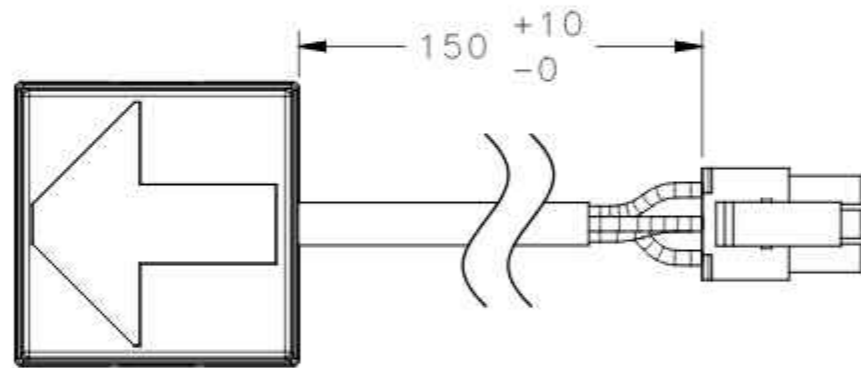

ES-01-0121 SHOWN

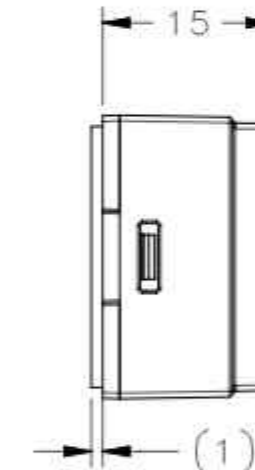
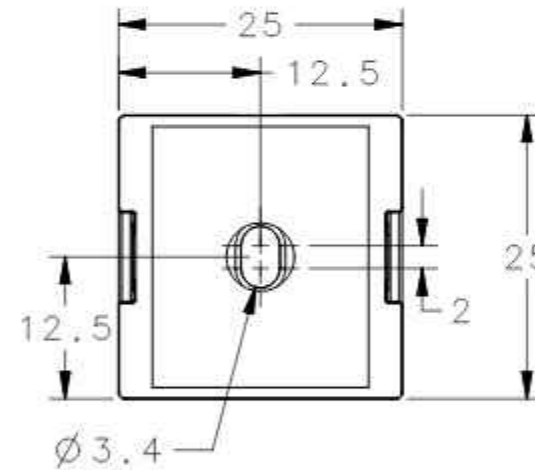

PRESSURE SENSITIVE ADHESIVE

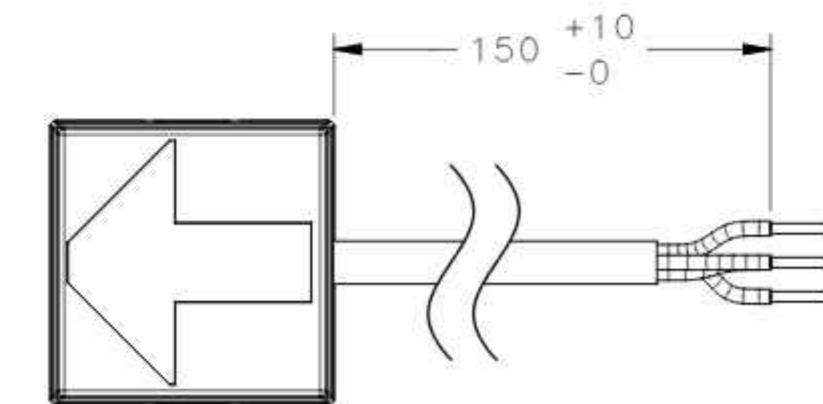

ES-01-0100 SHOWN

AVAILABLE PART NUMBERS	
PART NUMBER	CONNECTOR TYPE
ES-01-0100	STRIPPED AND TINNED
ES-01-0121	MOLEX MICROFIT 3.0 SERIES 6 PIN
CPB NUMBER 2019-1118	THIRD ANGLE PROJECTION
SURFACE AREA	MILLIMETERS [IN]
VOLUME	TOLERANCES UNLESS OTHERWISE NOTED
PROPRIETARY ITEM	ALL DIMENSIONS WITHOUT TOLERANCES ARE FOR REFERENCE ONLY.
EXCEPT FOR USES EXPRESSLY GRANTED IN WRITING, INFORMATION DISCLOSED HEREON IS CONFIDENTIAL AND ALL RIGHTS, PATENT AND OTHERWISE, ARE RESERVED BY SOUTHCO, INC.	DESCRIPTION ELECTRONIC ACCESS SOLUTION UNIVERSAL LATCH SENSOR SINGLE POLE DOUBLE THROW WITH ILLUMINATION
PER ASME Y14.5M-1994	SIZE A3 SYSTEM NX DWG NO. J-ES-01-1
DRAWN BY ZAM	DATE 20APR2021 SCALE 1.5:1 SHEET 1 OF 4



ELECTRICAL NOTES AND SPECIFICATIONS:

CAUTION: SWITCH HAS NO INHERENT PROTECTION. SUFFICIENT CIRCUIT PROTECTION MUST BE PROVIDED TO PREVENT DAMAGE TO PRODUCT.

CAUTION: LOAD OR CIRCUIT PROTECTION REQUIRED ON NORMALLY OPEN AND NORMALLY CLOSED LEGS OR UNIT WILL SHORT TO GROUND

CAUTION: UNIT HAS NO REVERSE POLARITY PROTECTION, ENSURE CORRECT POLARITY.

REVISION HISTORY			
REV	DATE	BY	DESCRIPTION
C	16DEC2021	ZAM/MLL	PRN: P2021-1200

PARAMETER	UNITS	MIN	NOM	MAX
SWITCHED VOLTAGE	VDC	9.6	12	14.4
SWITCHED CURRENT	A	-	-	0.400
LED CURRENT DRAW @ 12VDC		0.010	0.015	0.020

PIN NUMBER	WIRE COLOR	FUNCTION
1	BROWN	GROUND (-)
2	RED	POWER (+)
3	-	-
4	-	-
5	BLUE	NORMALLY OPEN
6	GRAY	NORMALLY CLOSED

	GRAY (NC) TO GND	BLUE (NO) TO GND	LATCH POSITION	INTEGRATED LED STATUS
MAGNET IN RANGE*	OPEN CIRCUIT	CLOSED CIRCUIT	LATCHED	OFF
MAGNET OUT OF RANGE*	CLOSED CIRCUIT	OPEN CIRCUIT	UNLATCHED	ON

* - SEE NOTE BELOW

PARAMETER	UNITS	MIN	NOM	MAX
OPERATING TEMPERATURE	C	-40	-	80

- NOTE:**
- MAGNET IN RANGE REFERS TO THE MAGNET BEING WITHIN THE ACTIVATION RANGE OF THE SWITCH.
 - MAGNET OUT OF RANGE REFERS TO THE MAGNET BEING OUTSIDE OF THE ACTIVATION RANGE OF THE SWITCH.
 - ALL DATA COLLECTED AT AMBIENT TEMPERATURES UNLESS OTHERWISE NOTED.
 - ACTIVATION RANGE SHOWN REPRESENTS INSTALLATION ON STEEL SURFACE.

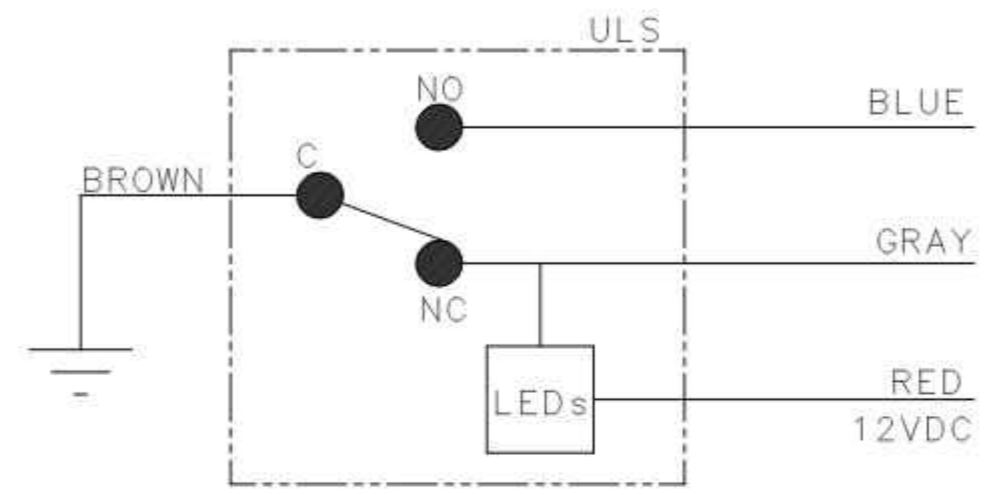

CPB NUMBER 2019-1118	THIRD ANGLE PROJECTION		southco [®] CONNECT • CREATE • INNOVATE	
	MILLIMETERS [IN]			
SURFACE AREA	TOLERANCES UNLESS OTHERWISE NOTED		ELECTRONIC ACCESS SOLUTION	
VOLUME	ALL DIMENSIONS WITHOUT TOLERANCES ARE FOR REFERENCE ONLY.		UNIVERSAL LATCH SENSOR SINGLE POLE DOUBLE THROW WITH ILLUMINATION	
PROPRIETARY ITEM	SIZE A3	SYSTEM NX	DWG NO. J-ES-01-1	
EXCEPT FOR USES EXPRESSLY GRANTED IN WRITING, INFORMATION DISCLOSED HEREON IS CONFIDENTIAL AND ALL RIGHTS, PATENT AND OTHERWISE, ARE RESERVED BY SOUTHCO, INC.	PER ASME Y14.5M-1994	DRAWN BY ZAM	DATE 20APR2021	SCALE 1:1 SHEET 2 OF 4

REVISION HISTORY			
REV	DATE	BY	DESCRIPTION
C	16DEC2021	ZAM/MLL	PRN: P2021-1200

ASSEMBLY NOTES AND INSTRUCTIONS:

- E. PERFORMANCE MAY VARY WITH APPLICATION CONDITIONS.
- F. INSTALLATION IN PROXIMITY TO EXTERNAL MAGNETIC FIELDS OR MATERIALS WITH DIFFERING MAGNETIC PERMEABILITY WILL AFFECT PERFORMANCE AND ACTUATION RANGE.
- G. PRESSURE SENSITIVE ADHESIVE IS PRE-INSTALLED FOR MOUNTING.
- H. THE MOUNTING SLOT CAN BE USED WITH AN M3 OR #4-40 SCREW OR STUD.
A TRUSS, ROUND, OR PAN HEAD SCREW IS PREFERRED. AN M3 OR #4-40 THIN NUT CAN BE USED TO SECURE SCREW/STUD TO MOUNTING PLATE. MOUNTING SCREW, STUD, AND NUT ARE NOT INCLUDED. MAXIMUM ALLOWABLE INSTALL TORQUE, 22.5N-cm [2 in-lbs].
- I. ENSURE MOUNTING SURFACE IS CLEAN BEFORE SECURING TAPE.
- J. ENSURE SENSOR IS PROPERLY POSITIONED AND ALIGNED WITH MAGNET BEFORE SECURING TAPE.
ARROW ON UNIT HOUSING POINTS TO LOCATION OF INTERNAL REED SWITCH.
- K. REMOVE BACKING FROM TAPE TO EXPOSE ADHESIVE SURFACE.
LOCATE AND ATTACH BACK PLATE IN DESIRED LOCATION.
- L. PRESS BACK PLATE AND TAPE INTO POSITION TO ACTIVATE ADHESIVE.
- M. OPTIONALLY SECURE IN PLACE WITH SCREW OR NUT.
- N. ALIGN TOP HOUSING WITH BACK PLATE AND PUSH ON UNTIL FULLY SEATED.

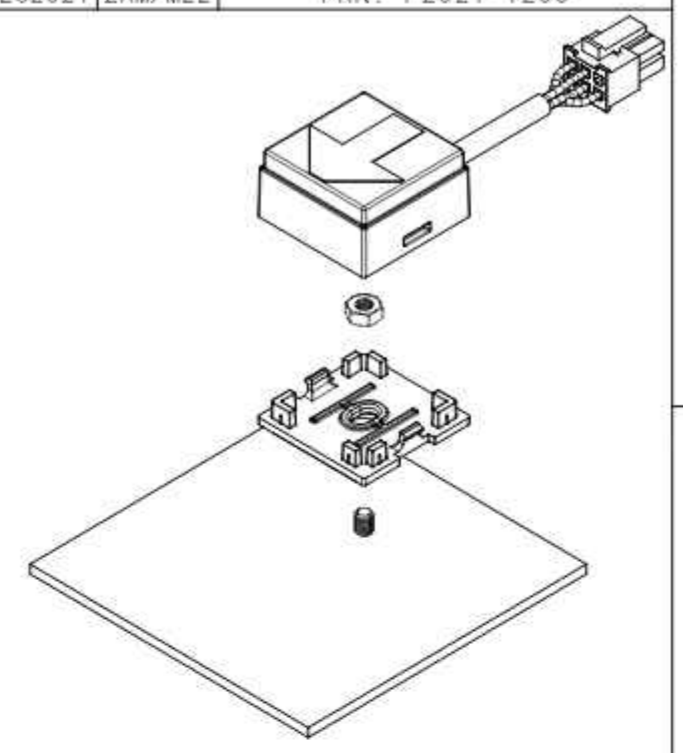

POSSIBLE INSTALLATION ORIENTATIONS

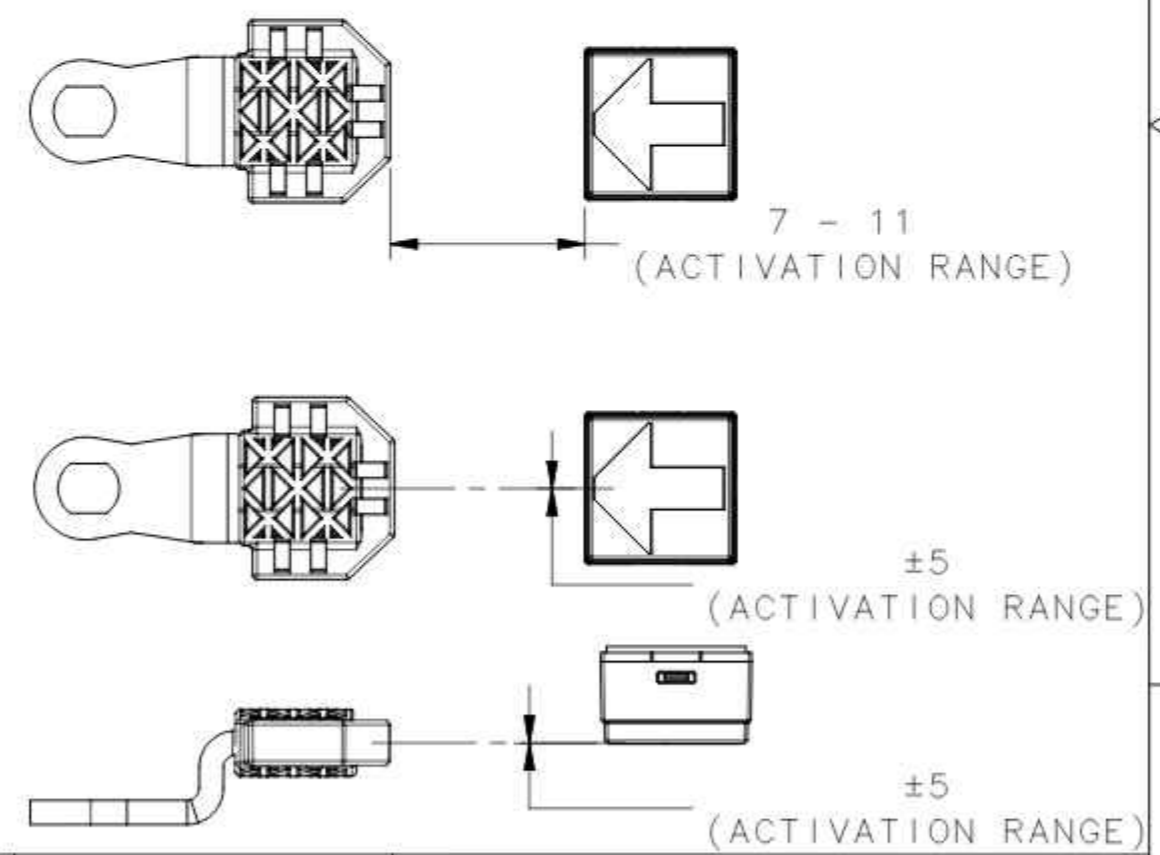
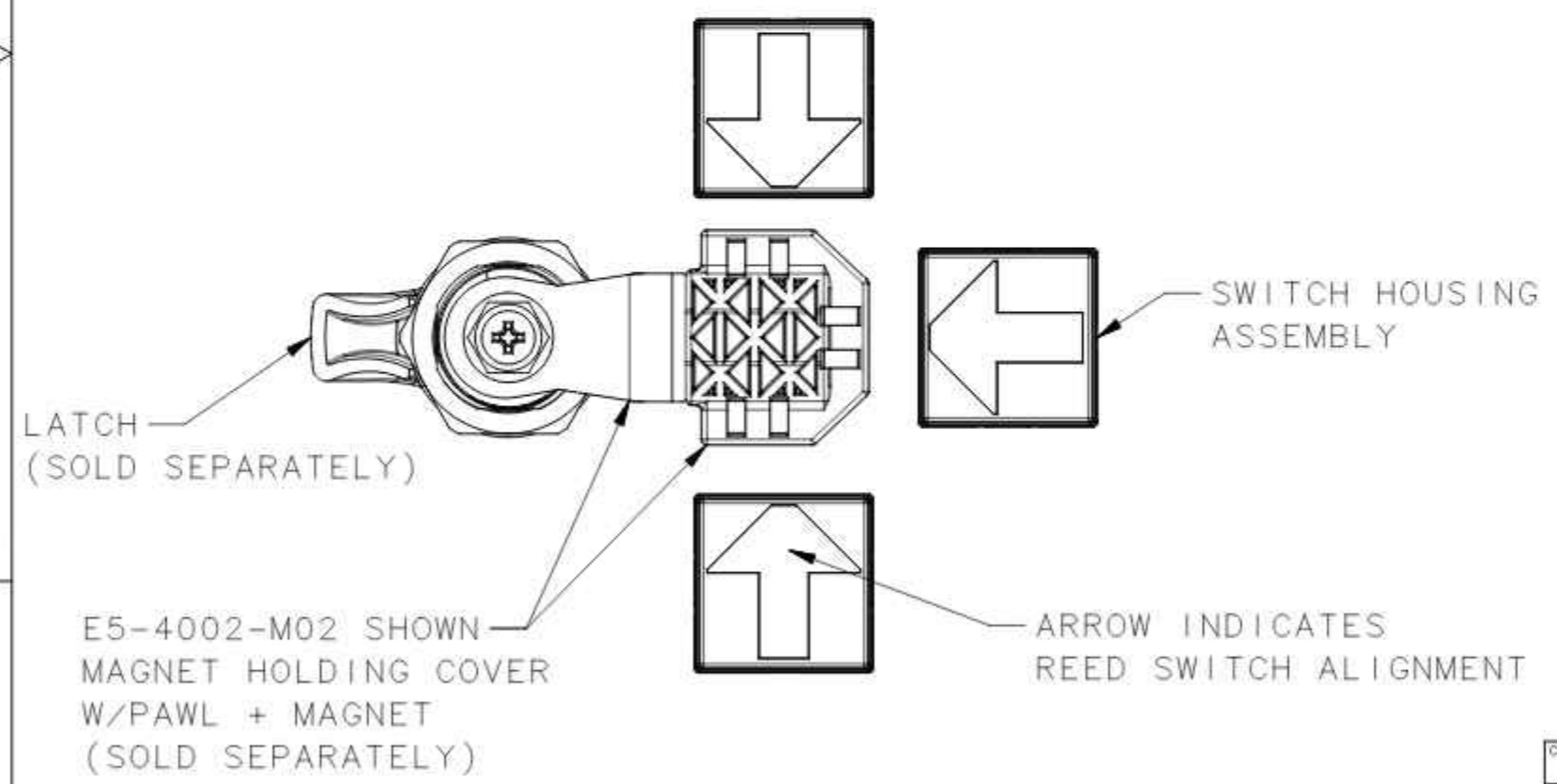

NOTE: MAGNET SPECIFICATIONS
 - GRADE: N42
 - SIZE: 12.7 X 4.76 X 4.76mm

CPB NUMBER 2019-1118	THIRD ANGLE PROJECTION	southco CONNECT • CREATE • INNOVATE		
SURFACE AREA	MILLIMETERS [IN]			
VOLUME	TOLERANCES UNLESS OTHERWISE NOTED	DESCRIPTION ELECTRONIC ACCESS SOLUTION UNIVERSAL LATCH SENSOR SINGLE POLE DOUBLE THROW WITH ILLUMINATION		
PROPRIETARY ITEM EXCEPT FOR USES EXPRESSLY GRANTED IN WRITING, INFORMATION DISCLOSED HEREON IS CONFIDENTIAL AND ALL RIGHTS, PATENT AND OTHERWISE, ARE RESERVED BY SOUTHCO, INC.	ALL DIMENSIONS WITHOUT TOLERANCES ARE FOR REFERENCE ONLY.	SIZE A3	SYSTEM NX	DWG NO. J-ES-01-1
	PER ASME Y14.5M-1994	DRAWN BY ZAM	DATE 20APR2021	SCALE NONE
				SHEET 3 OF 4

NOTES:
 O. SEE ADDITIONAL DRAWINGS FOR FURTHER INFORMATION.

- LATCH: J-E5-6-1
- MAGNET CAM: J-E5-4000-M

PARTS REQUIRED		
PART	PART NUMBER	REFERENCE DRAWING
LATCH	E5-6-HF-01	J-E5-6-1
CAM	E5-4000-M	J-E5-4000-M
UNIVERSAL LATCH SENSOR	ES-01-01XX	J-ES-01-1

REVISION HISTORY			
REV	DATE	BY	DESCRIPTION
C	16DEC2021	ZAM/MLL	PRN: P2021-1200

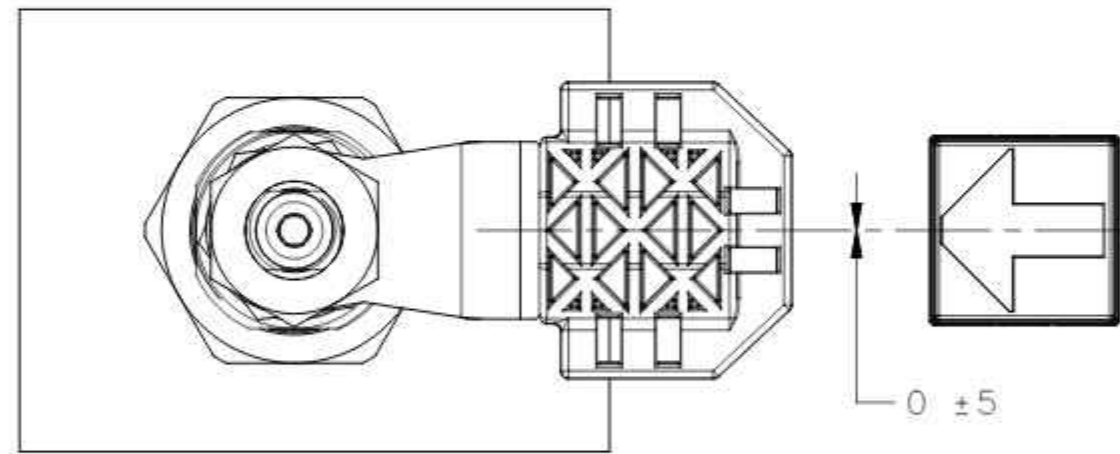
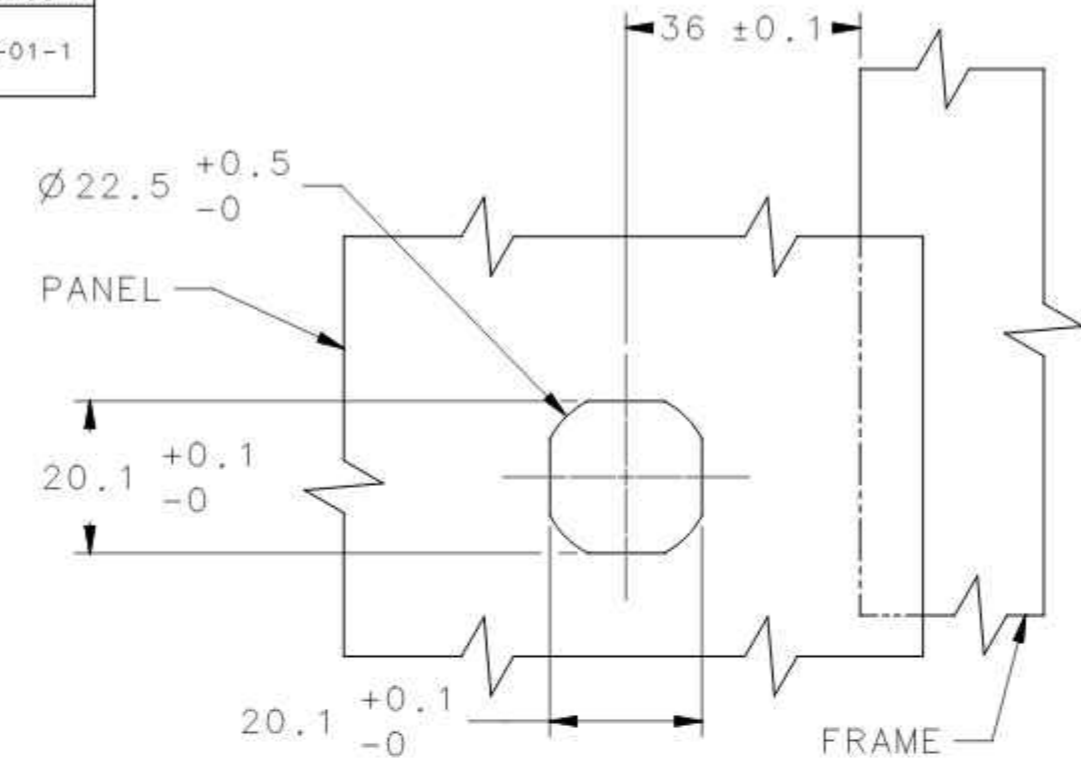
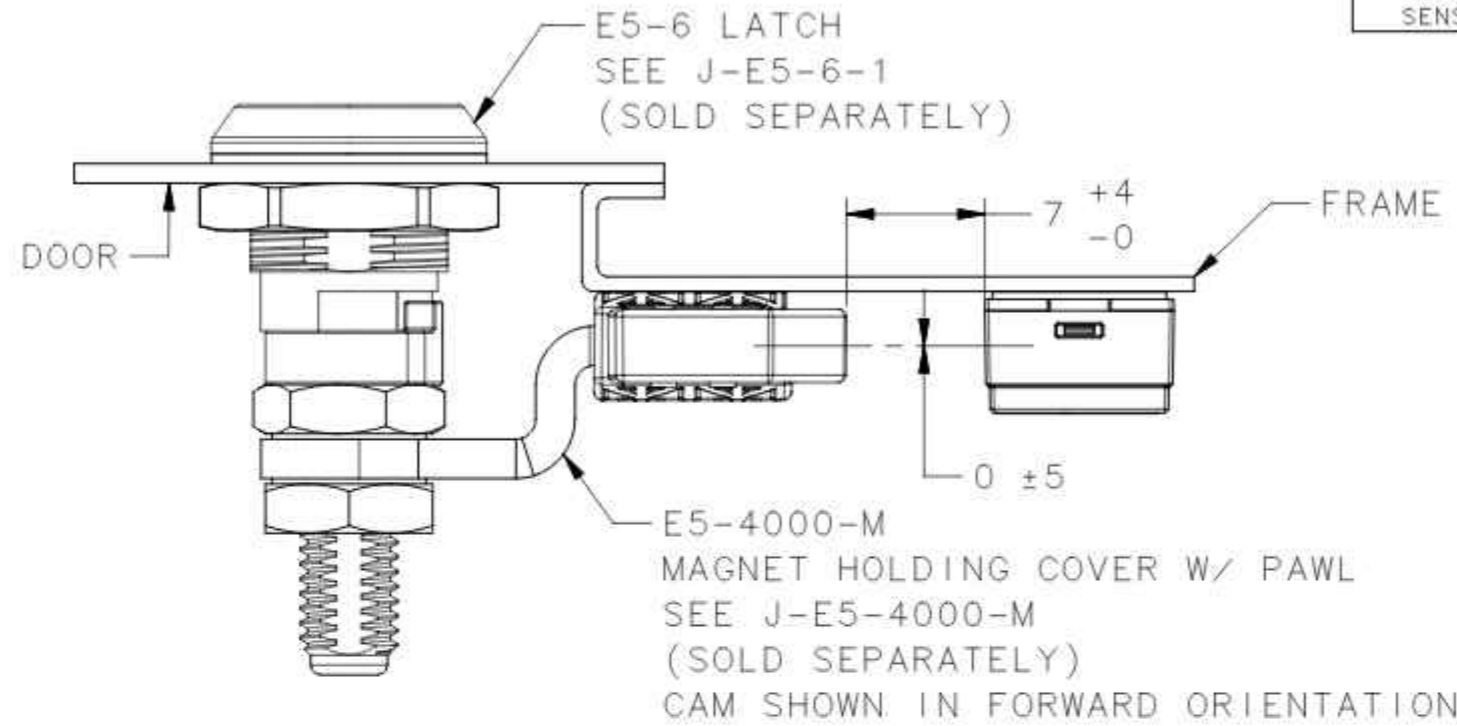

6mm MAX PANEL THICKNESS
 1mm MIN PANEL THICKNESS

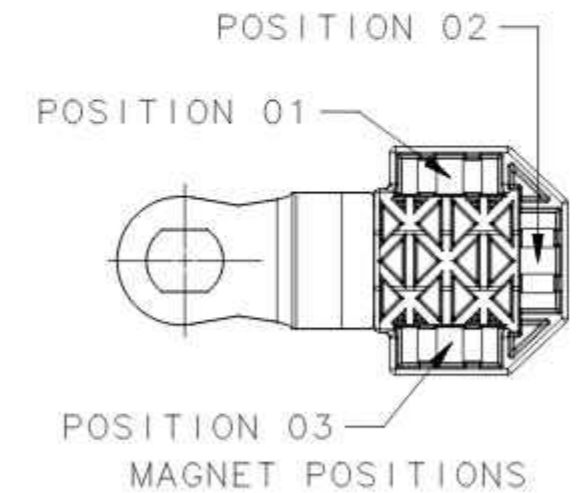
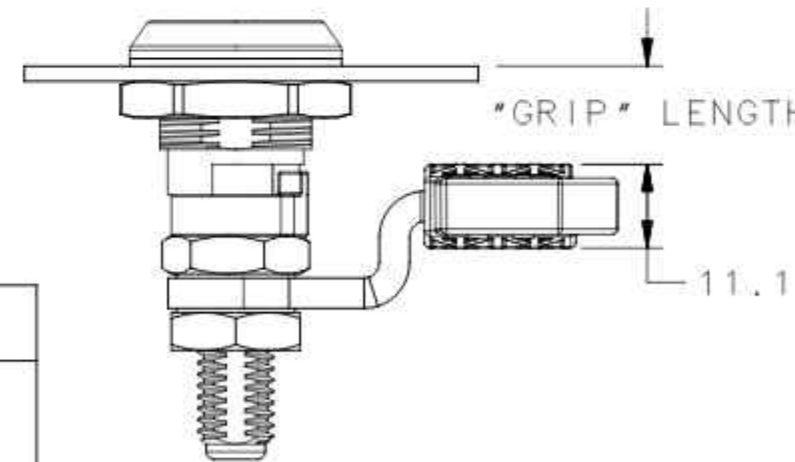
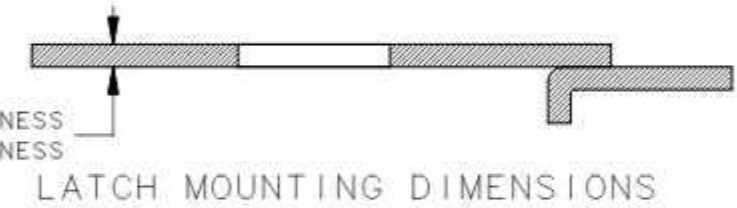

CAM FOR USE WITH ES UNIVERSAL LATCH SENSOR - PART NUMBER TABLE
 (ORDER SEPARATELY FROM LATCH)

MINIMUM GRIP +2(0.08)/-0	MAXIMUM GRIP +2(0.08)/-0	CAM ORIENTATION	OFFSET	MAGNET POSITION	PART NUMBER
3.5 (0.14)	15 (0.59)	FORWARD	DEEP OFFSET CAM	POSITION 1	E5-4001-M01
49.5 (1.95)	61 (2.40)	REVERSED		POSITION 2	E5-4001-M02
				POSITION 3	E5-4001-M03
15 (0.59)	26.5 (1.04)	FORWARD	OFFSET CAM	POSITION 1	E5-4002-M01
38 (1.50)	49.5 (1.95)	REVERSED		POSITION 2	E5-4002-M02
				POSITION 3	E5-4002-M03
26.5 (1.04)	38 (1.50)	-	STRAIGHT CAM	POSITION 1	E5-4003-M01
				POSITION 2	E5-4003-M02
				POSITION 3	E5-4003-M03

CPB NUMBER 2019-1118	THIRD ANGLE PROJECTION	
SURFACE AREA	MILLIMETERS [IN]	
VOLUME	TOLERANCES UNLESS OTHERWISE NOTED	DESCRIPTION ELECTRONIC ACCESS SOLUTION UNIVERSAL LATCH SENSOR SINGLE POLE DOUBLE THROW WITH ILLUMINATION
PROPRIETARY ITEM EXCEPT FOR USES EXPRESSLY GRANTED IN WRITING, INFORMATION DISCLOSED HEREON IS CONFIDENTIAL AND ALL RIGHTS, PATENT AND OTHERWISE ARE RESERVED BY SOUTHCO, INC.	ALL DIMENSIONS WITHOUT TOLERANCES ARE FOR REFERENCE ONLY.	
PER ASME Y14.5M-1994	SIZE A3 SYSTEM NX DWG NO. J-ES-01-1	SCALE NONE SHEET 4 OF 4
	DRAWN BY ZAM DATE 06OCT2021	

PHYSICAL AND MECHANICAL NOTES:

- A. PRODUCT DESCRIPTION: MAGNETICALLY OPERATED NORMALLY OPEN PROXIMITY SWITCH
- B. MATERIAL
 - HOUSING: POLYCARBONATE, CLEAR, UL94 V-0 RATED
 - BASE PLATE: PC/ABS, BLACK, UL94 V-0 RATED
 - PRESSURE SENSITIVE ADHESIVE: ACRYLIC ADHESIVE WITH FOAM CORE
 - WIRE: UL 1007, 26AWG (7/32), PVC INSULATION
- C. CONNECTOR TYPE
 - STRIPPED AND TINNED
- D. ENVIRONMENTAL
 - ALL ITEMS COMPLY WITH RoHS DIRECTIVE AND REACH REGULATION
 - IP67 RATED

REVISION HISTORY			
REV	DATE	BY	DESCRIPTION
C	16DEC2021	ZAM/MLL	PRN: P2021-1200

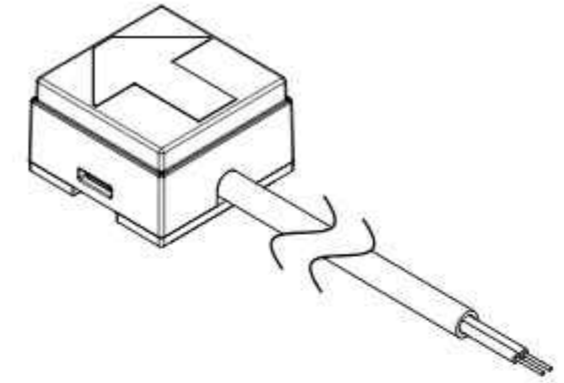

SCALE 1:1

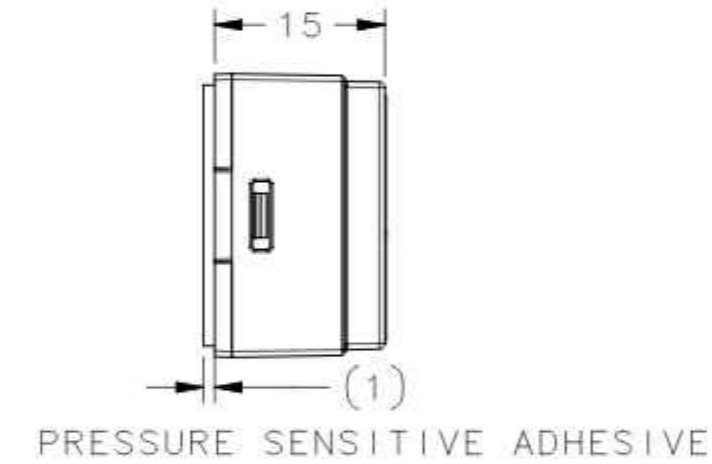
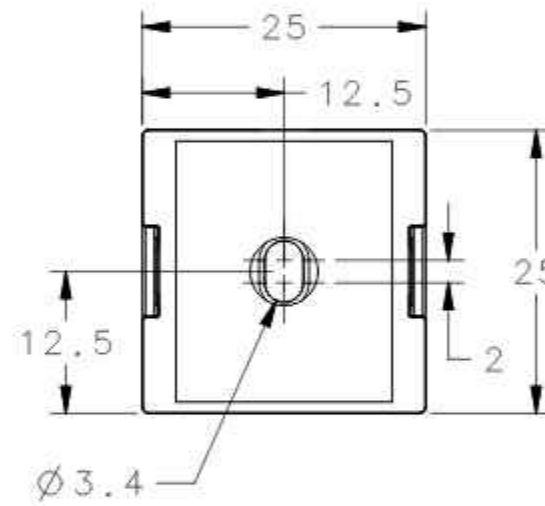
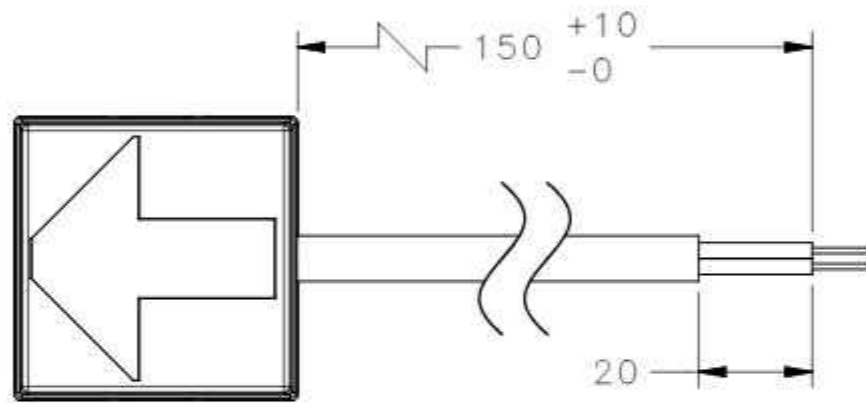

AVAILABLE PART NUMBERS	
PART NUMBER	CONNECTOR TYPE
ES-01-0200	STRIPPED AND TINNED
CPB NUMBER 2019-1118	THIRD ANGLE PROJECTION
	MILLIMETERS [IN]
SURFACE AREA	TOLERANCES UNLESS OTHERWISE NOTED
VOLUME	ALL DIMENSIONS WITHOUT TOLERANCES ARE FOR REFERENCE ONLY.
PROPRIETARY ITEM EXCEPT FOR USES EXPRESSLY GRANTED IN WRITING, INFORMATION DISCLOSED HEREON IS CONFIDENTIAL AND ALL RIGHTS, PATENT AND OTHERWISE ARE RESERVED BY SOUTHCO, INC.	DESCRIPTION ELECTRONIC ACCESS SOLUTION UNIVERSAL LATCH SENSOR NORMALLY OPEN
PER ASME Y14.5M-1994	SIZE A3 SYSTEM NX DWG NO. J-ES-01-2
	DRAWN BY ZAM DATE 21APR2021 SCALE 1.5:1 SHEET 1 OF 4



ELECTRICAL NOTES AND SPECIFICATIONS

REVISION HISTORY			
REV	DATE	BY	DESCRIPTION
C	16DEC2021	ZAM/MLL	PRN: P2021-1200

CAUTION: SWITCH HAS NO INHERENT PROTECTION. SUFFICIENT CIRCUIT PROTECTION MUST BE PROVIDED TO PREVENT DAMAGE TO PRODUCT.

CAUTION: DO NOT CONNECT POWER ACROSS SWITCH. POWER TO GROUND SHORT WILL RESULT.

TABLE 1: ELECTRICAL AND PERFORMANCE CHARACTERISTICS (@ 25 °C)

PARAMETER	UNITS	MIN	NOM	MAX
SWITCHED CURRENT*	A	-	-	0.500
SWITCHED POWER	W	-	-	10
SWITCHED VOLTAGE (DC)	VDC	-	-	200
SWITCHED VOLTAGE (AC)	VAC	-	-	140
BREAKDOWN VOLTAGE	V _{max}	200	-	-

TABLE 2: PINOUT

WIRE COLOR	FUNCTION
BLACK	COMMON
BLACK	NORMALLY OPEN

TABLE 3: ES-1-0200 UNIT STATUS WHEN OPERATED WITH MAGNET

	CIRCUIT STATUS	LATCH STATUS
MAGNET IN RANGE*	CLOSED CIRCUIT	LATCHED
MAGNET OUT OF RANGE*	OPEN CIRCUIT	UNLATCHED

* - SEE NOTE BELOW

TABLE 4: OPERATING TEMPERATURE

PARAMETER	UNITS	MIN	NOM	MAX
OPERATING TEMPERATURE	C	-40	-	80

NOTE:

- SWITCHED CURRENT WAS OBTAINED WITH 1KOHM RESISTOR IN LINE WITH SWITCH
- MAGNET IN RANGE REFERS TO THE MAGNET BEING WITHIN THE ACTIVATION RANGE OF THE SWITCH.
- MAGNET OUT OF RANGE REFERS TO THE MAGNET BEING OUTSIDE OF THE ACTIVATION RANGE OF THE SWITCH.
- ACTIVATION RANGE SHOWN REPRESENTS INSTALLATION ON STEEL SURFACE.
- ALL DATA COLLECTED AT AMBIENT TEMPERATURES UNLESS OTHERWISE NOTED.

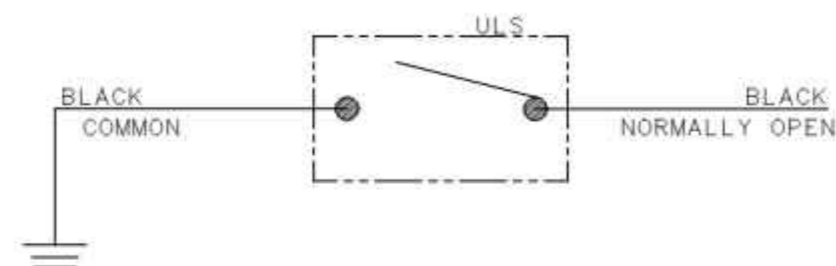

CPB NUMBER 2019-1118	THIRD ANGLE PROJECTION	southco [®] CONNECT • CREATE • INNOVATE	
	MILLIMETERS [IN]		
SURFACE AREA	TOLERANCES UNLESS OTHERWISE NOTED	ELECTRONIC ACCESS SOLUTION	
VOLUME	ALL DIMENSIONS WITHOUT TOLERANCES ARE FOR REFERENCE ONLY.	UNIVERSAL LATCH SENSOR NORMALLY OPEN	
PROPRIETARY ITEM <small>EXCEPT FOR USES EXPRESSLY GRANTED IN WRITING, INFORMATION DISCLOSED HEREON IS CONFIDENTIAL AND ALL RIGHTS, PATENT AND OTHERWISE ARE RESERVED BY SOUTHCO, INC.</small>	PER ASME Y14.5M-1994	SIZE A3	SYSTEM NX
		DWG NO. J-ES-01-2	
		DRAWN BY ZAM	DATE 21APR2021
		SCALE 1:1	SHEET 2 OF 4

ASSEMBLY NOTES AND INSTRUCTIONS:

- E. PERFORMANCE MAY VARY WITH APPLICATION CONDITIONS.
- F. INSTALLATION IN PROXIMITY TO EXTERNAL MAGNETIC FIELDS OR MATERIALS WITH HIGH MAGNETIC PERMEABILITY WILL AFFECT PERFORMANCE AND ACTUATION RANGE.
- G. PRESSURE SENSITIVE ADHESIVE IS PRE-INSTALLED FOR MOUNTING.
- H. THE MOUNTING SLOT CAN BE USED WITH AN M3 OR #4-40 SCREW OR STUD. A TRUSS, ROUND, OR PAN HEAD SCREW IS PREFERRED. AN M3 OR #4-40 THIN NUT CAN BE USED TO SECURE SCREW/STUD TO MOUNTING PLATE. MOUNTING SCREW, STUD, AND NUT ARE NOT INCLUDED. MAXIMUM ALLOWABLE INSTALL TORQUE, 22.5N-cm [2 in-lbs].
- I. ENSURE MOUNTING SURFACE IS CLEAN BEFORE SECURING TAPE.
- J. ENSURE SENSOR IS PROPERLY POSITIONED AND ALIGNED WITH MAGNET BEFORE SECURING TAPE. ARROW ON UNIT HOUSING POINTS TO LOCATION OF INTERNAL REED SWITCH.
- K. REMOVE BACKING FROM TAPE TO EXPOSE ADHESIVE SURFACE. LOCATE AND ATTACH BACK PLATE IN DESIRED LOCATION.
- L. PRESS BACK PLATE AND TAPE INTO POSITION TO ACTIVATE ADHESIVE.
- M. OPTIONALLY SECURE IN PLACE WITH SCREW OR NUT.
- N. ALIGN TOP HOUSING WITH BACK PLATE AND PUSH ON UNTIL FULLY SEATED.

REVISION HISTORY			
REV	DATE	BY	DESCRIPTION
C	16DEC2021	ZAM/MLL	PRN: P2021-1200

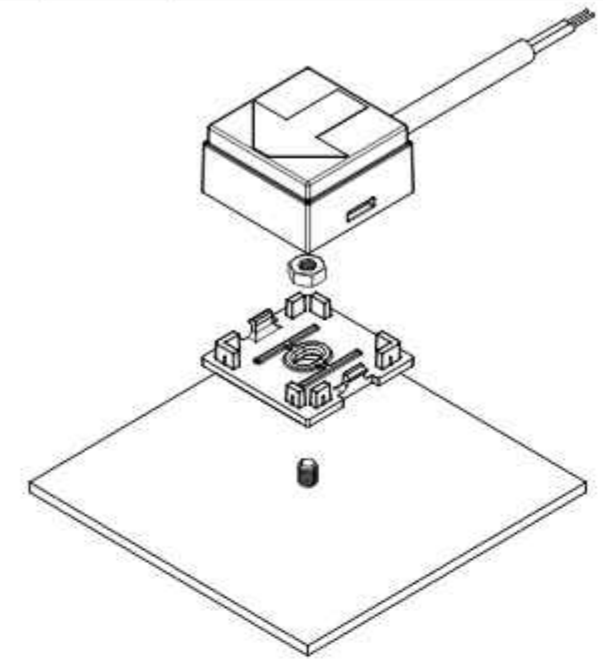

POSSIBLE MOUNTING ORIENTATIONS

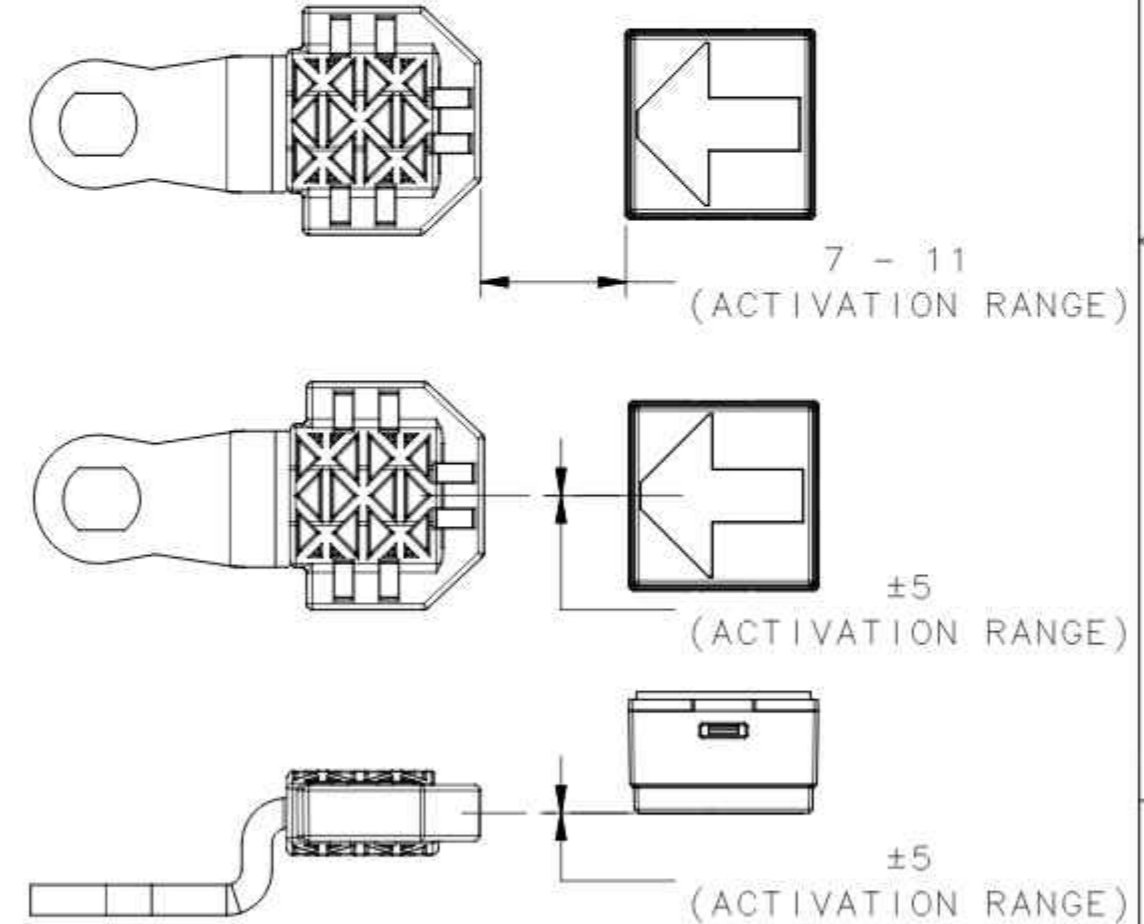
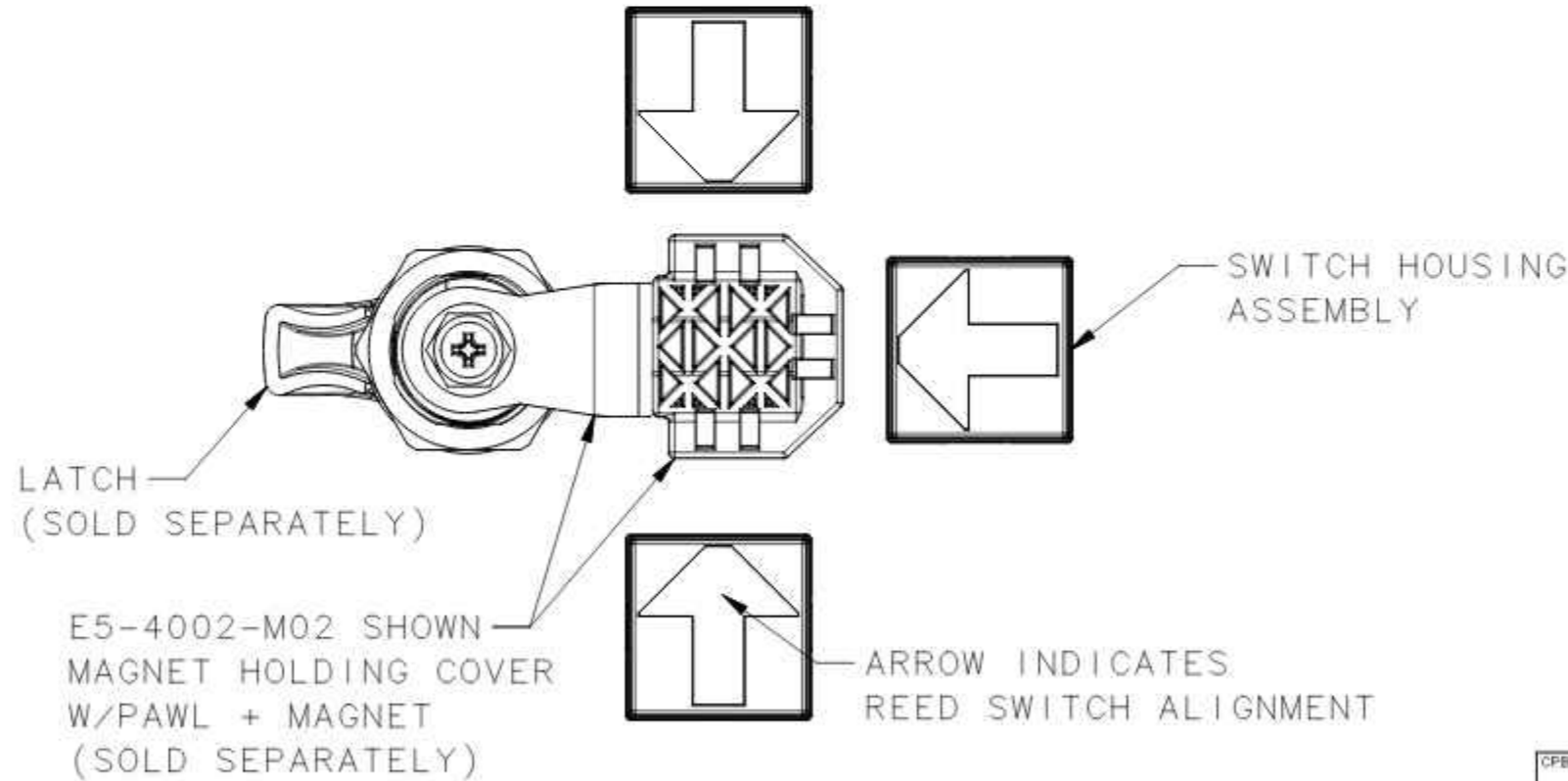

NOTE: MAGNET SPECIFICATIONS
 - GRADE: N42
 - SIZE: 12.7 x 4.76 x 4.76mm

CPB NUMBER 2019-1118	THIRD ANGLE PROJECTION	southco CONNECT • CREATE • INNOVATE	
	MILLIMETERS [IN]		
SURFACE AREA	TOLERANCES UNLESS OTHERWISE NOTED	DESCRIPTION ELECTRONIC ACCESS SOLUTION UNIVERSAL LATCH SENSOR NORMALLY OPEN	
VOLUME	ALL DIMENSIONS WITHOUT TOLERANCES ARE FOR REFERENCE ONLY.	SIZE A3	SYSTEM NX
PROPRIETARY ITEM EXCEPT FOR USES EXPRESSLY GRANTED IN WRITING, INFORMATION DISCLOSED HEREON IS CONFIDENTIAL AND ALL RIGHTS, PATENT AND OTHERWISE ARE RESERVED BY SOUTHCO, INC.	PER ASME Y14.5M-1994	DWG NO. J-ES-01-2	SCALE NONE
		DRAWN BY ZAM	DATE 21APR2021
			SHEET 3 OF 4

NOTES:
 O. SEE ADDITIONAL DRAWINGS FOR FURTHER INFORMATION.
 - LATCH: J-E5-6-1
 - MAGNET CAM: J-E5-4000-M

PARTS REQUIRED		
PART	PART NUMBER	REFERENCE DRAWING
LATCH	E5-6-HF-01	J-E5-6-1
CAM	E5-4000-M	J-E5-4000-M
UNIVERSAL LATCH SENSOR	ES-01-02XX	J-ES-01-2

REVISION HISTORY			
REV	DATE	BY	DESCRIPTION
C	16DEC2021	ZAM/MLL	PRN: P2021-1200

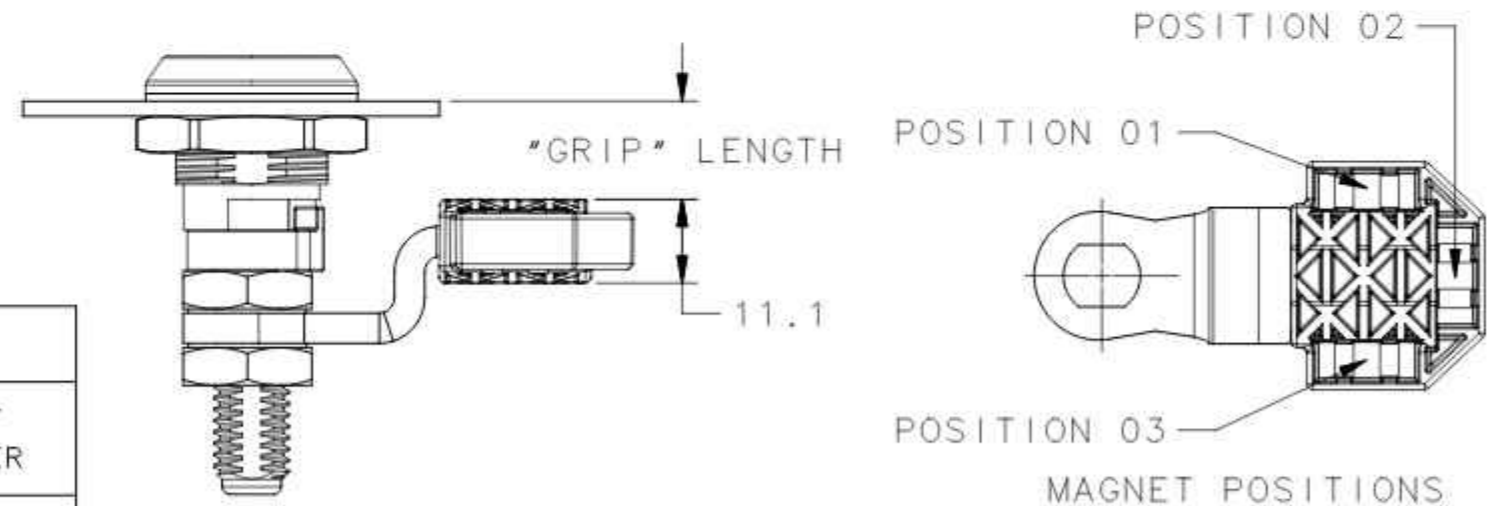
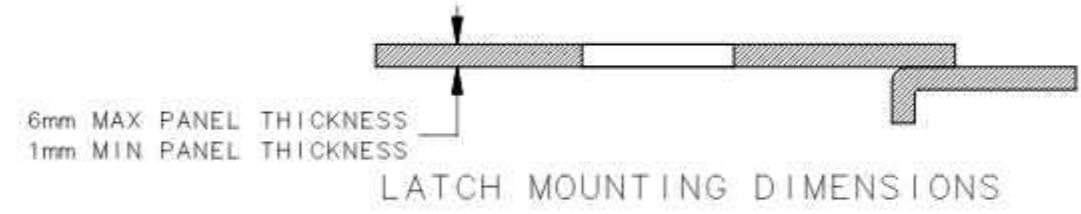
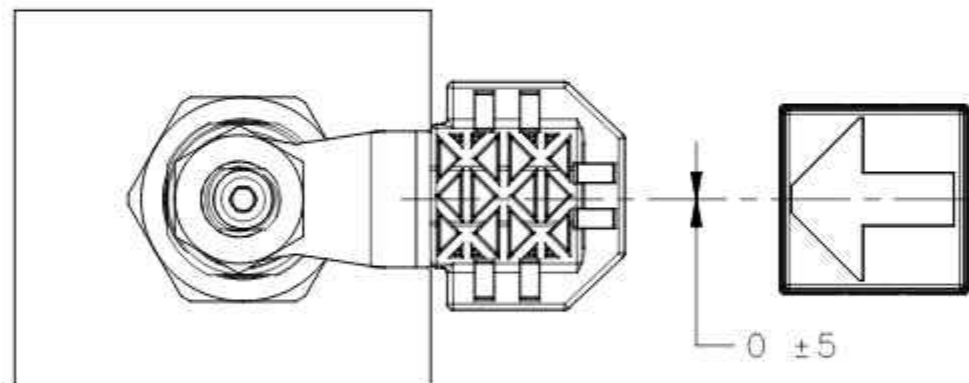
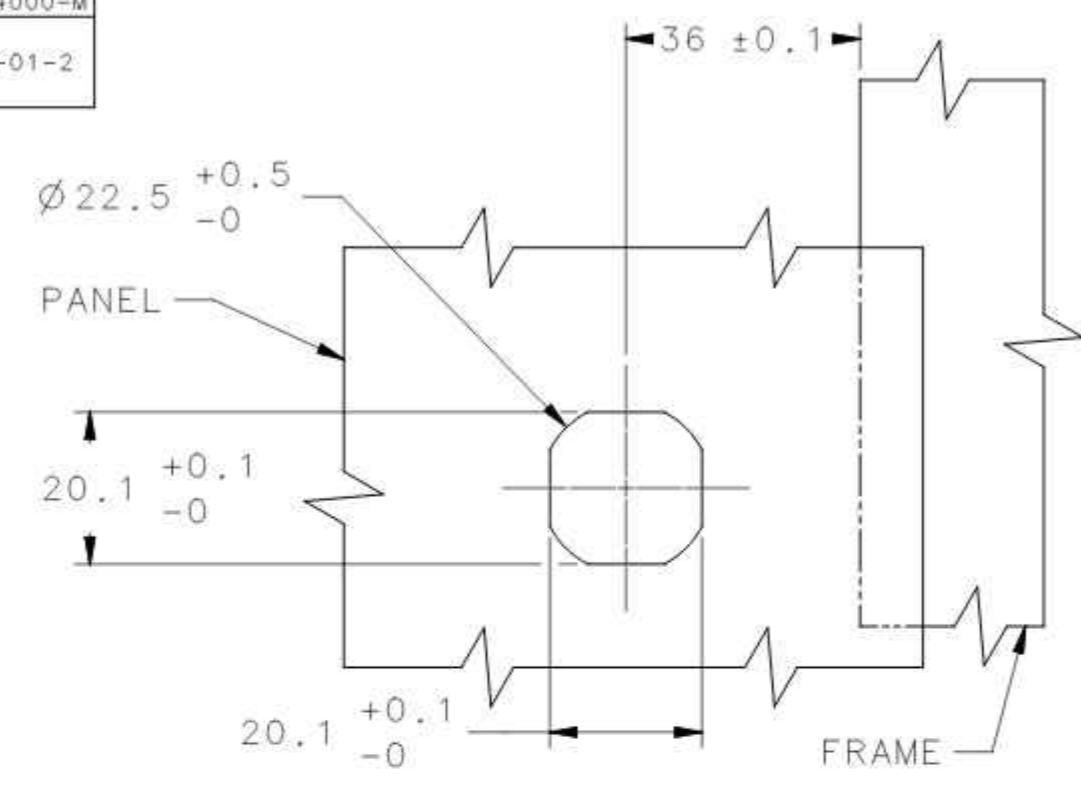
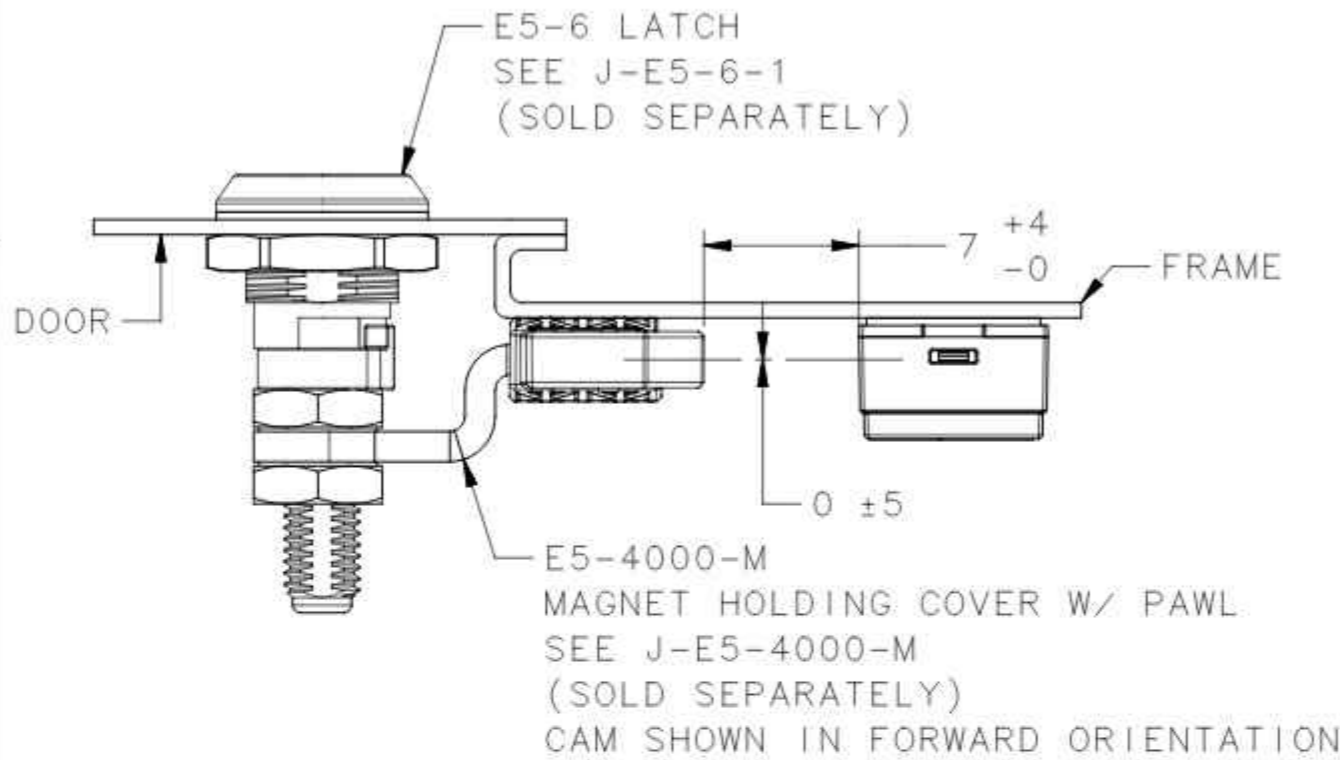

CAM FOR USE WITH ES UNIVERSAL LATCH SENSOR - PART NUMBER TABLE (ORDER SEPARATELY FROM LATCH)

MINIMUM GRIP +2(0.08)/-0	MAXIMUM GRIP +2(0.08)/-0	CAM ORIENTATION	OFFSET	MAGNET POSITION	PART NUMBER
3.5 (0.14)	15 (0.59)	FORWARD	DEEP OFFSET CAM	POSITION 1	E5-4001-M01
49.5 (1.95)	61 (2.40)	REVERSED		POSITION 2	E5-4001-M02
15 (0.59)	26.5 (1.04)	FORWARD		POSITION 3	E5-4001-M03
38 (1.50)	49.5 (1.95)	REVERSED	OFFSET CAM	POSITION 1	E5-4002-M01
				POSITION 2	E5-4002-M02
				POSITION 3	E5-4002-M03
26.5 (1.04)	38 (1.50)	-	STRAIGHT CAM	POSITION 1	E5-4003-M01
				POSITION 2	E5-4003-M02
				POSITION 3	E5-4003-M03

CPB NUMBER 2019-1118	THIRD ANGLE PROJECTION	southco CONNECT • CREATE • INNOVATE
SURFACE AREA	MILLIMETERS [IN]	
VOLUME	TOLERANCES UNLESS OTHERWISE NOTED	DESCRIPTION ELECTRONIC ACCESS SOLUTION UNIVERSAL LATCH SENSOR NORMALLY OPEN
PROPRIETARY ITEM EXCEPT FOR USES EXPRESSLY GRANTED IN WRITING, INFORMATION DISCLOSED HEREON IS CONFIDENTIAL AND ALL RIGHTS, PATENT AND OTHERWISE, ARE RESERVED BY SOUTHCO, INC.	ALL DIMENSIONS WITHOUT TOLERANCES ARE FOR REFERENCE ONLY.	SIZE A3
PER ASME Y14.5M-1994	DRAWN BY ZAM	DATE 18NOV2021
	SCALE NONE	SHEET 4 OF 4