

Hole reduction sleeve

for TCC clamps, technopolymer

MATERIAL

Glass fibre reinforced polyamide based (PA) technopolymer, RAL 9005 (C9) black colour or grey RAL 7040 (C33) colour, matte finish.

FEATURES

Hole reduction sleeve for tubes with diameter "dt" ± 0.2 mm.
The hole reduction sleeve fits into the housing hole of the TCC clamps so that smaller diameter tubes can be used.

TECHNICAL DATA

The resistance values shown in the table were measured during laboratory tests at ambient temperature with the screws tightened to the maximum torque of 5 Nm for TCC A 18 and 12 Nm for TCC A 30.



ELESA Original design

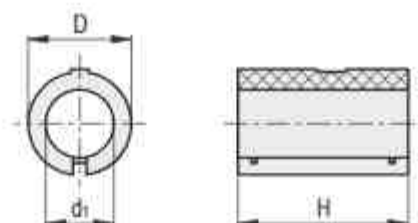
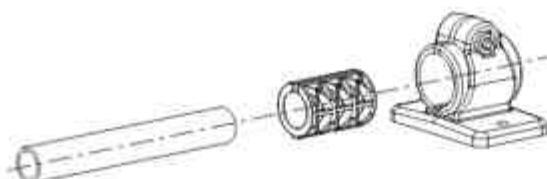

C9
 C33
 RAL 9005 RAL 7040

Code	Description	Code	Description	D	H	dt	∅
600101 C9	TCC A 18 12 C9	600101 C33	TCC A 18 12 C33	18	29	12	5
600102 C9	TCC A 18 14 C9	600102 C33	TCC A 18 14 C33	18	29	14	4
600103 C9	TCC A 18 15 C9	600103 C33	TCC A 18 15 C33	18	29	15	4
600104 C9	TCC A 18 16 C9	600104 C33	TCC A 18 16 C33	18	29	16	3
600201 C9	TCC A 30 20 C9	600201 C33	TCC A 30 20 C33	30	45	20	15
600202 C9	TCC A 30 25 C9	600202 C33	TCC A 30 25 C33	30	45	25	10

Resistance to tube pull-out (F1) and rotation (M1) with the hole reduction sleeves inserted in the different types of clamps

	TCC-AB		TCC-CR		TCC-SL		TCC-TB		TCC-TS	
	F1 [N]	M1 [Nm]	F1 [N]	M1 [Nm]	F1 [N]	M1 [Nm]	F1 [N]	M1 [Nm]	F1 [N]	M1 [Nm]
TCC-A-18-12	900	5	1250	5	900	5	900	5	900	5
TCC-A-18-14	1000	7	1650	10	1400	7	1050	8	1200	7
TCC-A-18-15	1000	7	1650	14	1400	10	1100	13	1200	11
TCC-A-18-16	1050	7	2000	14	1300	11	1200	14	1250	12
TCC-A-30-20	1000	8	1000	5	1000	6	1150	7	1000	6
TCC-A-30-25	1350	11	1300	7	1300	7	1600	7	1400	7

	TCC-AP		TCC-TP		TCC-AP-AP		TCC-AP-PB	
	F1 [N]	M1 [Nm]	F1 [N]	M1 [Nm]	F1 [N]	M1 [Nm]	F1 [N]	M1 [Nm]
TCC-A-30-20	1600	12	1600	12	1600	12	1600	12
TCC-A-30-25	2700	15	2700	15	2700	15	2700	15

	TCC-AP-PBF		TCC-AP-TP		TCC-TP-PB		TCC-TP-PBF	
	F1 [N]	M1 [Nm]	F1 [N]	M1 [Nm]	F1 [N]	M1 [Nm]	F1 [N]	M1 [Nm]
TCC-A-30-20	1600	12	1600	12	1600	12	1600	12
TCC-A-30-25	2700	15	2700	15	2700	15	2700	15

Connecting clamps with mounting base

Technopolymer

CLAMP

Glass fibre reinforced polyamide based (PA) technopolymer, RAL 9005 (C9) black colour or grey RAL 7040 (C33) colour, matte finish.

SCREW AND NUT (SUPPLIED)

Cylindrical head screws with hexagon socket in AISI 304 stainless steel with anti seizure treatment.

Self locking nut in AISI 304 stainless steel.

FEATURES

Clamps for tubes with a diameter of 18 ± 0.2 and 30 ± 0.2 mm. For smaller diameter tubes, the hole reduction sleeves TCC A can be used (ordered separately).

The "s" grub screw may be replaced by the kit TCC-KS.

TECHNICAL DATA

The resistance values shown in the table were measured during laboratory tests at ambient temperature with the screws tightened to the maximum torque "C#".

ACCESSORIES ON REQUEST (TO BE ORDERED SEPARATELY)

TCC A (see page): reduction sleeves.

TCC-KS (see page): clamping kit.

TCC-KV (see page): screws and clamping nuts.

GN 990 (see page): connecting tubes.



ELESA Original design

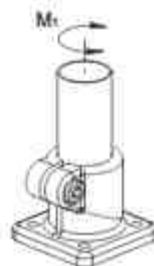
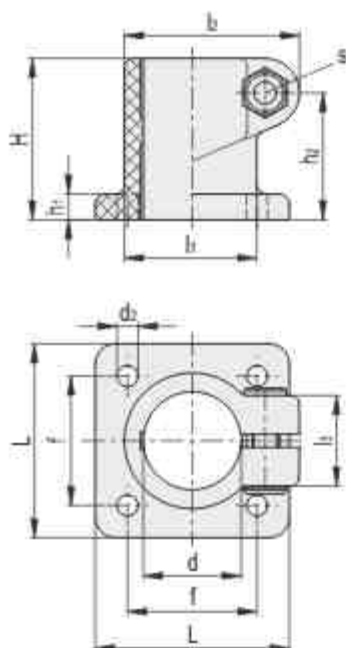

■ C9 RAL9005 ■ C33 RAL7040

STAINLESS STEEL

Code	Description	d	L	H	d2	f±0.2	h1	h2	t1	t2	t3	s	C# [Nm]	F1* [N]	M1** [Nm]	σ _{0.2}
600111 C9	TCC AB 18 C9	18	45	34	5.3	30	5	25	26	36.5	20	M6	5	1050	8	29
600111 C33	TCC AB 18 C33	18	45	34	5.3	30	5	25	26	36.5	20	M6	5	1050	8	29
600211 C9	TCC AB 30 C9	30	60	50	6.5	40	8	40	40	53.5	27	M8	12	1650	33	75
600211 C33	TCC AB 30 C33	30	60	50	6.5	40	8	40	40	53.5	27	M8	12	1650	33	75

Suggested torque for screw assembly

* Resistance to tube pull out

** Resistance to tube rotation

Clamps for hinged joints

Technopolymer

CLAMP

Glass fibre reinforced polyamide based (PA) technopolymer, RAL 9005 (C9) black colour or grey RAL 7040 (C33) colour, matte finish.

SCREWS AND NUTS

Cylindrical head screw with hexagon socket in AISI 304 stainless steel with anti seizure treatment.

Self locking nuts in AISI 304 stainless steel.

Supplied: two screws and two nuts for versions TCC AP-E and TCC AP-S, one screw and one nut for version TCC AP-I.

STANDARD EXECUTIONS

TCC-AP-E: external teeth.

TCC-AP-I: internal teeth.

TCC-AP-S: without teeth.

FEATURES

Two clamps, one with external teeth and one with internal teeth or two without teeth, can be joined to create a hinged joint.

Joints comprising clamps with external/internal teeth (36 teeth) have a 10° adjustment angle.

Joints comprising clamps without teeth can be positioned at any angle.

Clamps for tubes with a diameter of 30 ± 0.2 mm.

For smaller diameter tubes, the hole reduction sleeve can be used TCC A (to be ordered separately).

The "s" grub screws may be replaced by the kit TCC KS.

TECHNICAL DATA

The resistance values shown in the table were measured during laboratory tests at ambient temperature with the screws tightened to the maximum torque "C#".

ACCESSORIES ON REQUEST (TO BE ORDERED SEPARATELY)

TCC A (see page): reduction sleeves.

TCC KS (see page): clamping kit.

GN 197 (see page): monitor mounts.

TCC KV (see page): screws and clamping nuts.

GN 990 (see page): connecting tubes.



ELESA Original design



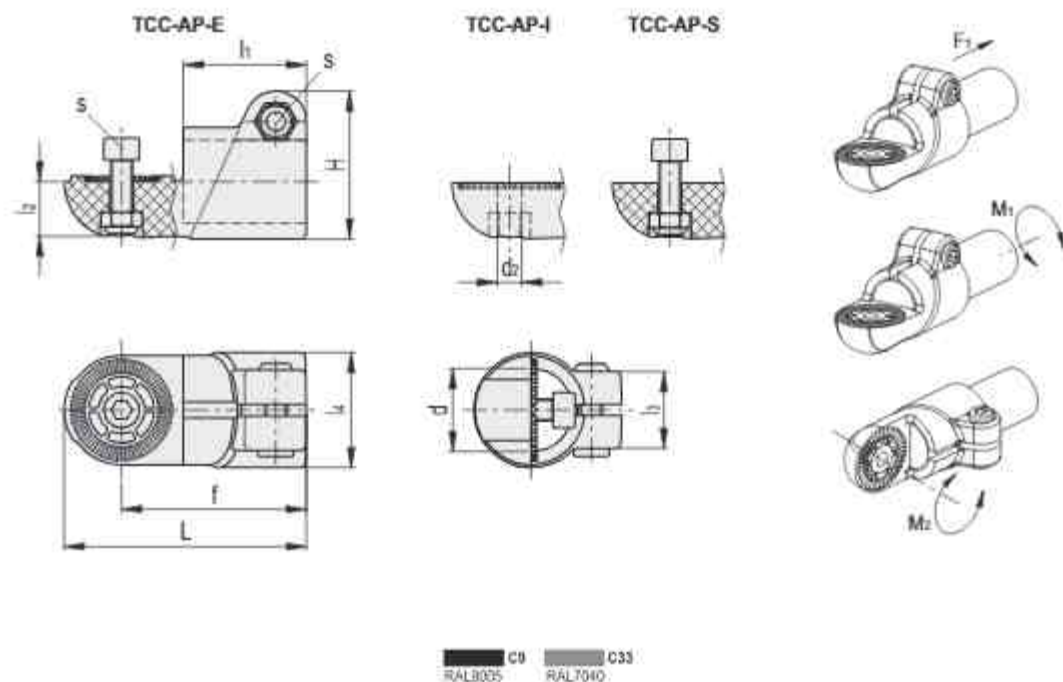

TCC-AP-E

STAINLESS STEEL

Code	Description	d	L	H	f	b	t ₂	t ₃	t ₄	s	C#	F1*	M1**	M2***	⚠
											[Nm]	[N]	[Nm]	[Nm]	
600401.C9	TCC-AP-30 E C9	30	88	54	67	45	16.5	27	42	M8	12	3300	33	140	80
600401.C33	TCC-AP-30 E C33	30	88	54	67	45	16.5	27	42	M8	12	3300	33	140	80

TCC-AP-I

STAINLESS STEEL

Code	Description	d	L	H	d ₂	f	b	t ₂	t ₃	t ₄	s	C#	F1*	M1**	M2***	⚠
												[Nm]	[N]	[Nm]	[Nm]	
600403.C9	TCC-AP-30 I C9	30	88	54	8.1	67	45	16.5	27	42	M8	12	3300	33	140	79
600403.C33	TCC-AP-30 I C33	30	88	54	8.1	67	45	16.5	27	42	M8	12	3300	33	140	79

TCC-AP-S

STAINLESS STEEL

Code	Description	d	L	H	f	b	t ₂	t ₃	t ₄	s	C#	F1*	M1**	M2***	⚠
											[Nm]	[N]	[Nm]	[Nm]	
600405.C9	TCC-AP-30 S C9	30	88	54	67	45	16.5	27	42	M8	12	3300	33	6	79
600405.C33	TCC-AP-30 S C33	30	88	54	67	45	16.5	27	42	M8	12	3300	33	6	79

Suggested torque for screw assembly.

* Resistance to tube pull out.

** Resistance to tube rotation.

*** Resistance to joint rotation.

Hinged joints with clamps

Technopolymer

CLAMPS

Glass fibre reinforced polyamide based (PA) technopolymer, RAL 9005 (C9) black colour or grey RAL 7040 (C33) colour, matte finish.

SCREWS AND NUTS (SUPPLIED)

Cylindrical head screw with hexagon socket in AISI 304 stainless steel with anti seizure treatment.

Self locking nuts in AISI 304 stainless steel.

STANDARD EXECUTIONS

TCC-AP-AP-T: with teeth.

TCC-AP-AP-S: without teeth.

FEATURES

Joints comprising clamps with external/internal teeth (36 teeth) have a 10° adjustment angle.

Joints comprising clamps without teeth can be positioned at any angle.

Clamps for tubes with a diameter of 30 ± 0.2 mm.

For smaller diameter tubes, the hole reduction sleeve can be used TCC A (to be ordered separately).

The "s" grub screws may be replaced by the kit TCC KS.

TECHNICAL DATA

The resistance values shown in the table were measured during laboratory tests at ambient temperature with the screws tightened to the maximum torque "C#".

ACCESSORIES ON REQUEST (TO BE ORDERED SEPARATELY)

TCC A (see page): reduction sleeves.

TCC KS (see page): clamping kit.

GN 197 (see page): monitor mounts.

TCC KV (see page): screws and clamping nuts.

GN 990 (see page): connecting tubes.



ELESA Original design

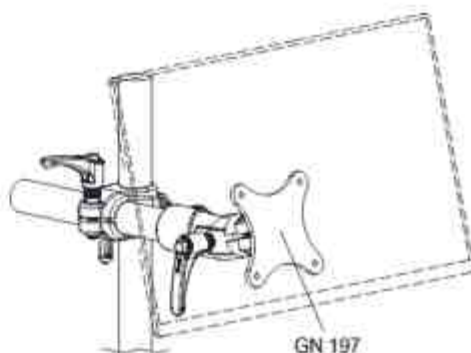

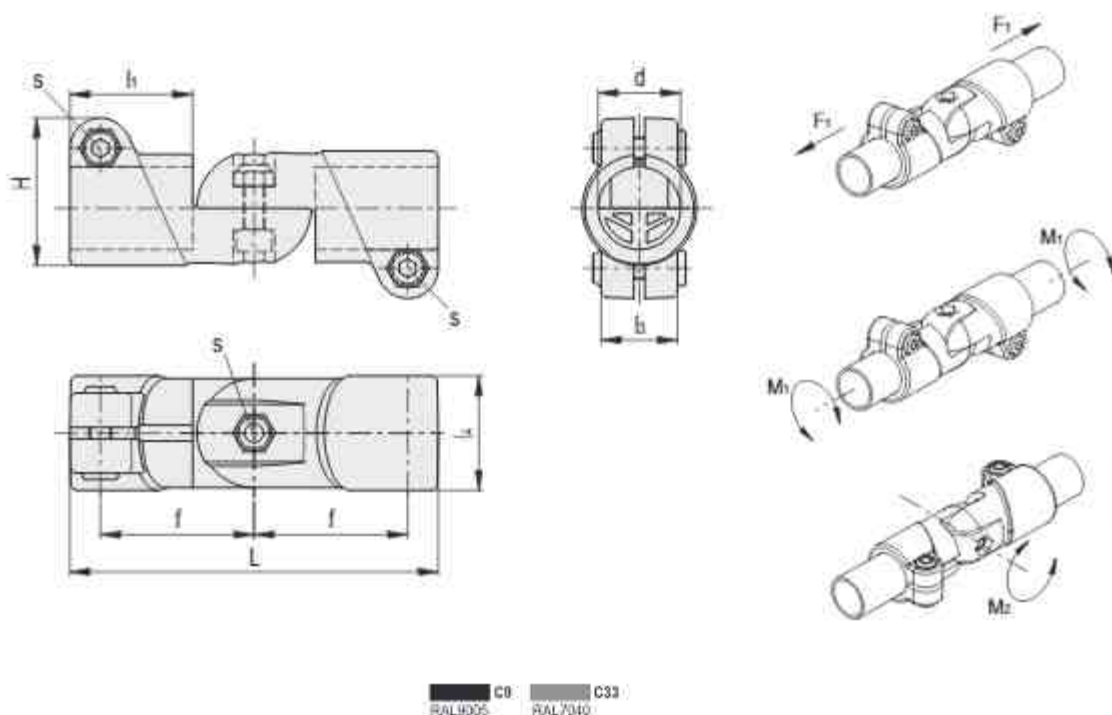

TCC-AP-AP-T

STAINLESS STEEL

Code	Description	d	L	H	f	b	B	H	s	C# [Nm]	F1* [N]	M1** [Nm]	M2*** [Nm]	⊕
600801 C9	TCC AP AP 30 T C9	30	135	54	56	45	27	42	M8	12	3300	33	140	178
600801 C33	TCC AP AP 30 T C33	30	135	54	56	45	27	42	M8	12	3300	33	140	178

TCC-AP-AP-S

STAINLESS STEEL

Code	Description	d	L	H	f	b	B	H	s	C# [Nm]	F1* [N]	M1** [Nm]	M2*** [Nm]	⊕
600802 C9	TCC AP AP 30 S C9	30	135	54	56	45	27	42	M8	12	3300	33	6	178
600802 C33	TCC AP AP 30 S C33	30	135	54	56	45	27	42	M8	12	3300	33	6	178

Suggested torque for screw assembly.

* Resistance to tube pull out.

** Resistance to tube rotation.

*** Resistance to joint rotation.

Hinged joint with mounting base and clamp

Technopolymer

CLAMP AND BASE

Glass fibre reinforced polyamide based (PA) technopolymer, RAL 9005 (CS) black colour or grey RAL 7040 (C33) colour, matte finish.

SCREWS AND NUTS (SUPPLIED)

Cylindrical head screw with hexagon socket in AISI 304 stainless steel with anti seizure treatment.

Self locking nuts in AISI 304 stainless steel.

STANDARD EXECUTIONS

TCC-AP-PB-T: with teeth.

TCC-AP-PB-S: without teeth.

FEATURES

Joints comprising bases with external teeth and clamps with internal teeth (36 teeth) have a 10° adjustment angle.

Joints comprising bases and clamps without teeth can be positioned at any angle.

Clamps for tubes with a diameter of 30 ± 0.2 mm.

For smaller diameter tubes, the hole reduction sleeve can be used TCC A (to be ordered separately).

The "s" grub screws may be replaced by the kit TCC-KS.

TECHNICAL DATA

The resistance values shown in the table were measured during laboratory tests at ambient temperature with the screws tightened to the maximum torque "C#".

ACCESSORIES ON REQUEST (TO BE ORDERED SEPARATELY)

TCC A (see page -): reduction sleeves.

TCC-KS (see page -): clamping kit.

GN 197 (see page -): monitor mounts.

TCC-KV (see page -): screws and clamping nuts.

GN 990 (see page -): connecting tubes.



ELESA Original design

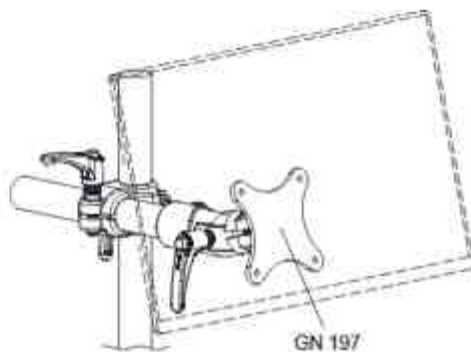
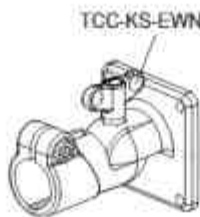

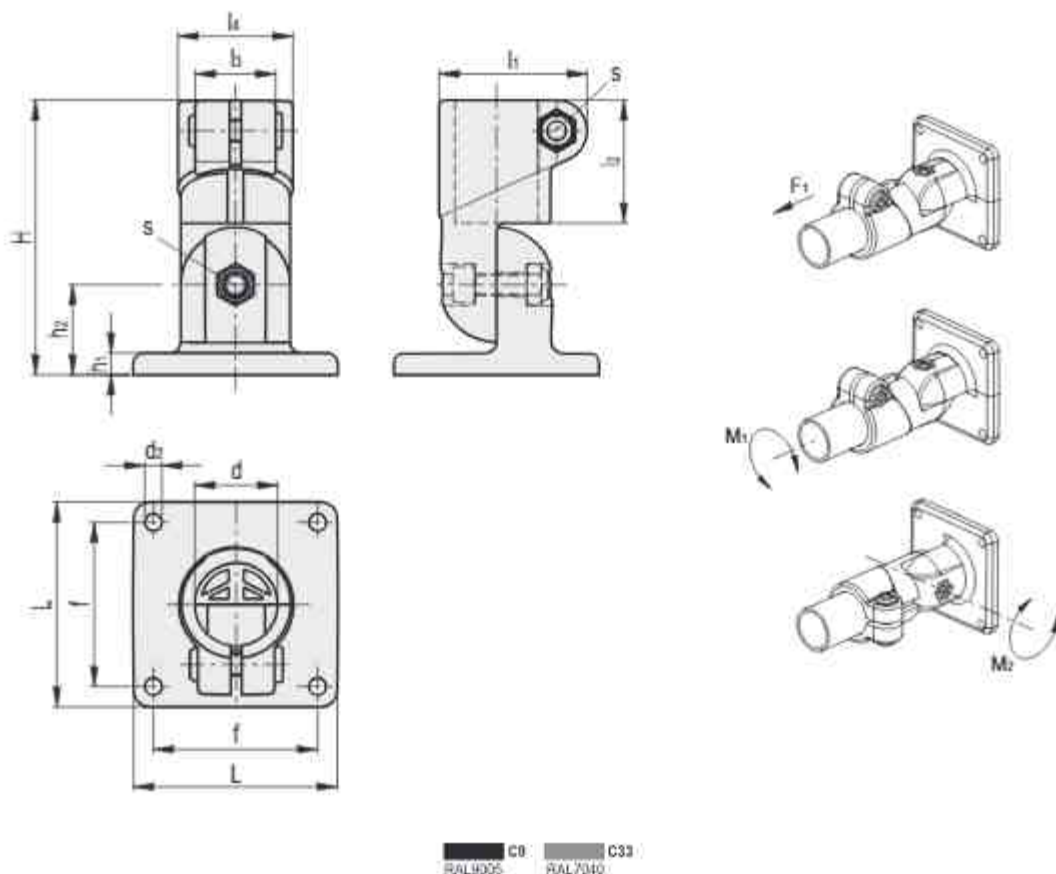

TCC-AP-PB-T

STAINLESS STEEL

Code	Description	d	L	H	d2	f±0.2	h1	h2	l1	l2	l3	l4	s	C#	F1* [Nm]	M1** [N]	M2*** [Nm]	⚙
600821 C9	TCC AP PB 30 T C9	30	75	100	6.5	60	8	33	54	45	27	42	M8	12	3300	33	100	157
600821 C33	TCC AP PB 30 T C33	30	75	100	6.5	60	8	33	54	45	27	42	M8	12	3300	33	100	157

TCC-AP-PB-S

STAINLESS STEEL

Code	Description	d	L	H	d2	f±0.2	h1	h2	l1	l2	l3	l4	s	C#	F1* [Nm]	M1** [N]	M2*** [Nm]	⚙
600822 C9	TCC AP PB 30 S C9	30	75	100	6.5	60	8	33	54	45	27	42	M8	12	3300	33	6	157
600822 C33	TCC AP PB 30 S C33	30	75	100	6.5	60	8	33	54	45	27	42	M8	12	3300	33	6	157

Suggested torque for screw assembly.

* Resistance to tube pull out.

** Resistance to tube rotation.

*** Resistance to joint rotation.

Hinged joint with mounting base and clamp

Technopolymer

CLAMP AND BASE

Glass fibre reinforced polyamide based (PA) technopolymer, RAL 9005 (C9) black colour or grey RAL 7040 (C33) colour, matte finish.

SCREWS AND NUTS (SUPPLIED)

Cylindrical head screw with hexagon socket in AISI 304 stainless steel with anti seizure treatment.

Self locking nuts in AISI 304 stainless steel.

STANDARD EXECUTIONS

TCC-AP-PBF-T with teeth.

TCC-AP-PBF-S without teeth.

FEATURES

Joints comprising bases with external teeth and clamps with internal teeth (36 teeth) have a 10° adjustment angle.

Joints comprising bases and clamps without teeth can be positioned at any angle.

Clamps for tubes with a diameter of 30 ± 0.2 mm.

For smaller diameter tubes, the hole reduction sleeve can be used TCC A (to be ordered separately).

The "s" grub screws may be replaced by the kit TCC-KS.

TECHNICAL DATA

The resistance values shown in the table were measured during laboratory tests at ambient temperature with the screws tightened to the maximum torque "C#".

ACCESSORIES ON REQUEST (TO BE ORDERED SEPARATELY)

TCC A (see page -): reduction sleeves.

TCC-KS (see page -): clamping kit.

GN 197 (see page -): monitor mounts.

TCC-KV (see page -): screws and clamping nuts.

GN 990 (see page -): connecting tubes.



ELESA Original design

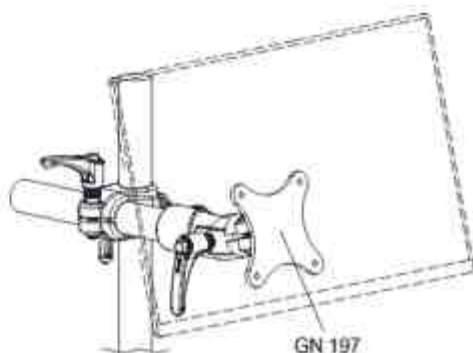
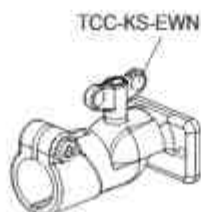

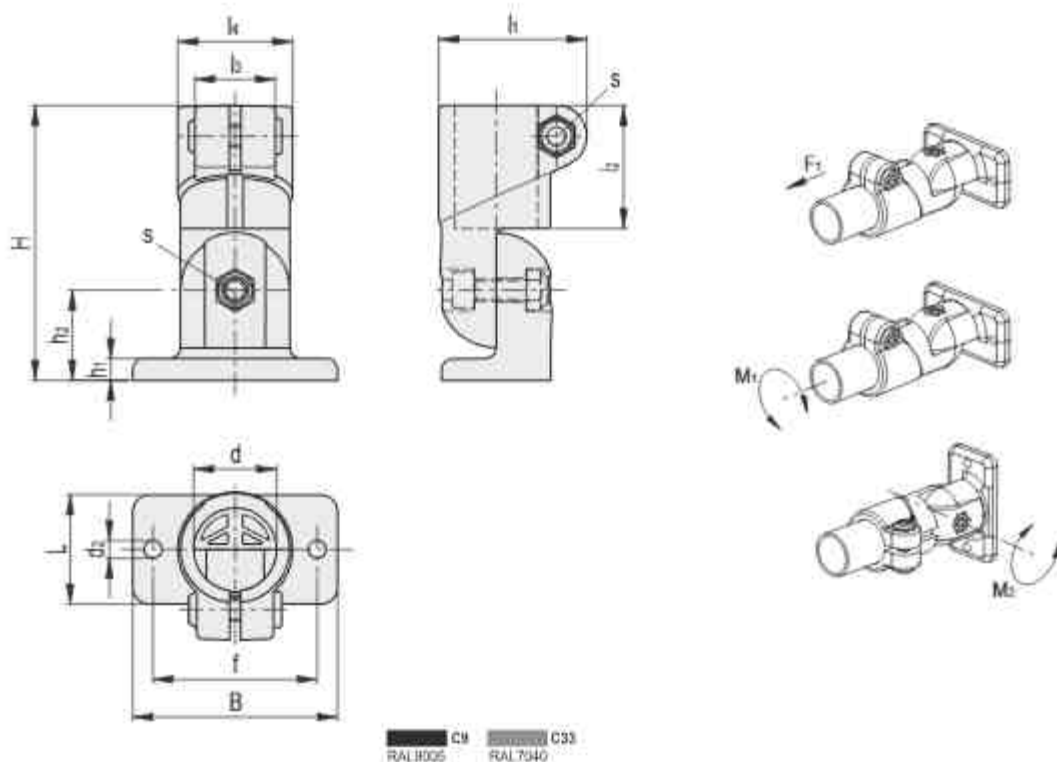

TCC-AP-PBF-T

STAINLESS STEEL

Code	Description	d	L	B	H	d2	f±0.2	h1	h2	l1	l2	l3	l4	α	C#	F1*	M1**	M2***	⊕
															[Nm]	[N]	[Nm]	[Nm]	
600831 C9	TCC AP PBF 30 T C9	30	40	75	100	6.5	60	8	33	54	45	27	42	M8	12	3300	33	100	142
600831 C33	TCC AP PBF 30 T C33	30	40	75	100	6.5	60	8	33	54	45	27	42	M8	12	3300	33	100	142

TCC-AP-PBF-S

STAINLESS STEEL

Code	Description	d	L	B	H	d2	f±0.2	h1	h2	l1	l2	l3	l4	α	C#	F1*	M1**	M2***	⊕
															[Nm]	[N]	[Nm]	[Nm]	
600832 C9	TCC AP PBF 30 S C9	30	40	75	100	6.5	60	8	33	54	45	27	42	M8	12	3300	33	6	142
600832 C33	TCC AP PBF 30 S C33	30	40	75	100	6.5	60	8	33	54	45	27	42	M8	12	3300	33	6	142

Suggested torque for screw assembly.

* Resistance to tube pull out.

** Resistance to tube rotation.

*** Resistance to joint rotation.

Hinged joints with clamps

Technopolymer

CLAMPS

Glass fibre reinforced polyamide based (PA) technopolymer, RAL 9005 (C9) black colour or grey RAL 7040 (C33) colour, matte finish.

SCREWS AND NUTS (SUPPLIED)

Cylindrical head screw with hexagon socket in AISI 304 stainless steel with anti seizure treatment.

Self locking nuts in AISI 304 stainless steel.

STANDARD EXECUTIONS

TCC-AP-TP-T: with teeth.

TCC-AP-TP-S: without teeth.

FEATURES

Joints comprising clamps with external/internal teeth (36 teeth) have a 10° adjustment angle.

Joints comprising clamps without teeth can be positioned at any angle.

Clamps for tubes with a diameter of 30 ± 0.2 mm.

For smaller diameter tubes, the hole reduction sleeve can be used TCC A (to be ordered separately).

The "s" grub screws may be replaced by the kit TCC KS.

TECHNICAL DATA

The resistance values shown in the table were measured during laboratory tests at ambient temperature with the screws tightened to the maximum torque "C#".

ACCESSORIES ON REQUEST (TO BE ORDERED SEPARATELY)

TCC A (see page): reduction sleeves.

TCC KS (see page): clamping kit.

GN 197 (see page): monitor mounts.

TCC KV (see page): screws and clamping nuts.

GN 990 (see page): connecting tubes.



ELESA Original design

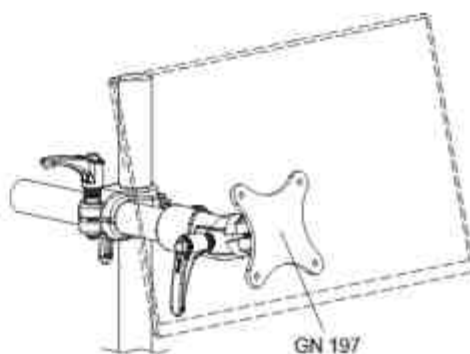
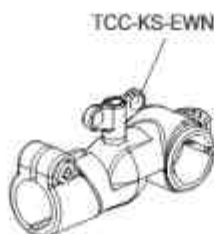

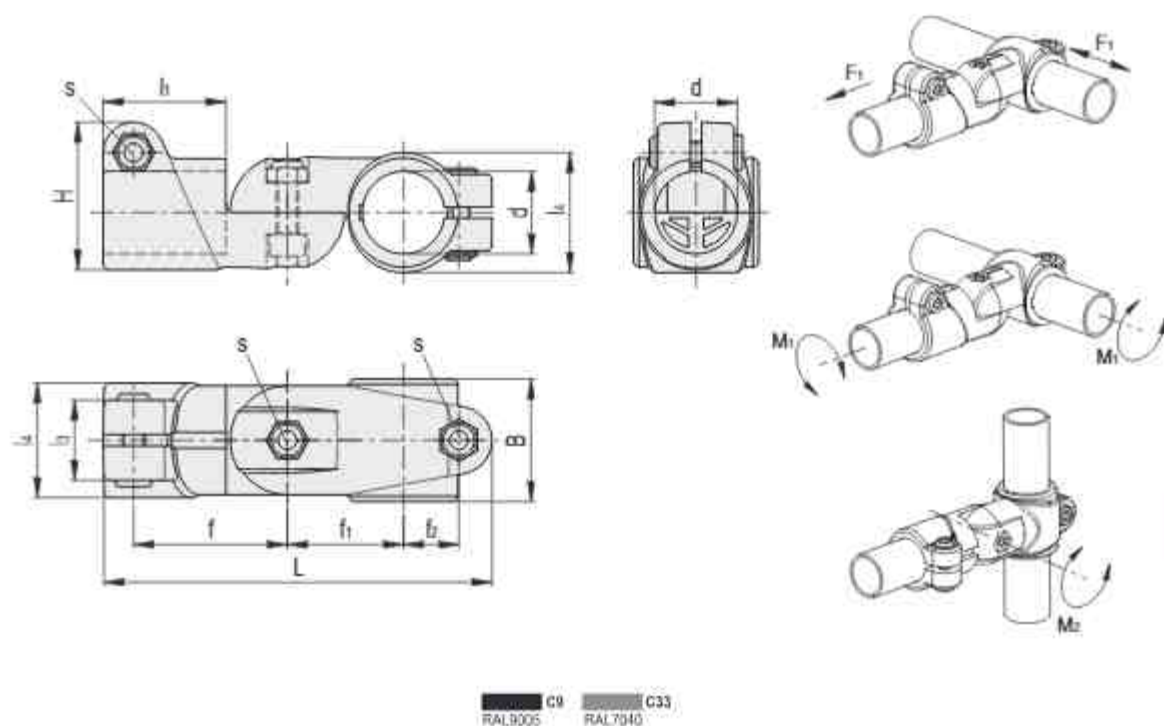

TCC-AP-TP-T

STAINLESS STEEL

Code	Description	d	L	B	H	f	f1	f2	t1	t2	t3	t4	n	C#	F1*	M1**	M2***	M3
															[Nm]	[N]	[Nm]	[Nm]
600811 C9	TCC AP TP 30 T C9	30	142	44.5	54	56	42	20.5	45	27	44	44	M8	12	3000	33	120	181
600811 C33	TCC AP TP 30 T C33	30	142	44.5	54	56	42	20.5	45	27	44	44	M8	12	3000	33	120	181

TCC-AP-TP-S

STAINLESS STEEL

Code	Description	d	L	B	H	f	f1	f2	t1	t2	t3	t4	n	C#	F1*	M1**	M2***	M3
															[Nm]	[N]	[Nm]	[Nm]
600812 C9	TCC AP TP 30 S C9	30	142	44.5	54	56	42	20.5	45	27	44	44	M8	12	3000	33	4	181
600812 C33	TCC AP TP 30 S C33	30	142	44.5	54	56	42	20.5	45	27	44	44	M8	12	3000	33	4	181

Suggested torque for screw assembly.

* Resistance to tube pull out.

** Resistance to tube rotation.

*** Resistance to joint rotation.

Two-way connecting clamps

Technopolymer

CLAMP

Glass fibre reinforced polyamide based (PA) technopolymer, RAL 9005 (C9) black colour or grey RAL 7040 (C33) colour, matte finish.

SCREWS AND NUTS (SUPPLIED)

Cylindrical head screw with hexagon socket in AISI 304 stainless steel with anti seizure treatment.

Self locking nuts in AISI 304 stainless steel.

FEATURES

Clamps for tubes with a diameter of 18 ± 0.2 and 30 ± 0.2 mm.

For smaller diameter tubes, the hole reduction sleeve TCC A can be used (ordered separately).

The "s" grub screws may be replaced by the kit TCC KS.

TECHNICAL DATA

The resistance values shown in the table were measured during laboratory tests at ambient temperature with the screws tightened to the maximum torque "C#".

ACCESSORIES ON REQUEST (TO BE ORDERED SEPARATELY)

TCC A (see page): reduction sleeves.

TCC KS (see page): clamping kit.

TCC KV (see page): screws and clamping nuts.

GN 990 (see page): connecting tubes.



ELESA Original design

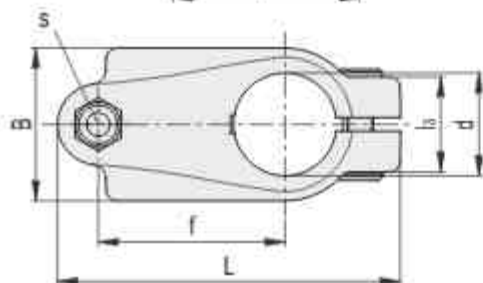
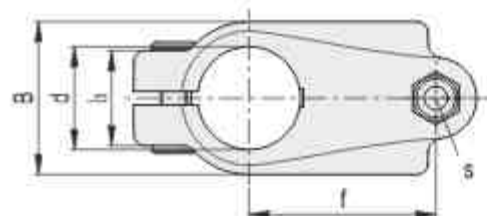

TCC-KS-ERX



TCC-KS-EWN

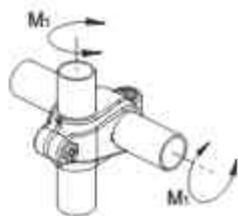
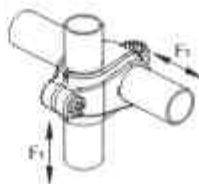

■ C9 RAL9005 ■ C33 RAL7040

STAINLESS-STEEL

Code	Description	d	L	B	f	b	s	C# [Nm]	F1* [N]	M1** [Nm]	σ _{0.2}
600121 C9	TCC CR 18 18 C9	18	65	29	34	21	M6	5	2150	17	41
600121 C33	TCC CR 18 18 C33	18	65	29	34	21	M6	5	2150	17	41
600221 C9	TCC CR 30 30 C9	30	100.5	45	54.5	27	M8	12	1350	21	123
600221 C33	TCC CR 30 30 C33	30	100.5	45	54.5	27	M8	12	1350	21	123

Suggested torque for screw assembly

* Resistance to tube pull out

** Resistance to tube rotation

Clamping kit for TCC

Technopolymer

ADJUSTABLE HANDLE AND WING NUT

Glass fibre reinforced polyamide based (PA) technopolymer, gray black colour, matte finish.

DISTANCE BUSHING

Glass fibre reinforced polyamide based (PA) technopolymer, black colour, matte finish.

SELF-LOCKING NUT

AISI 304 stainless steel.

STANDARD EXECUTIONS

TCC-KS-ERX: adjustable handle with AISI 303 stainless steel threaded stud, chamfered flat end UNI 947 - ISO 4753 (see Technical data on page), with black push button.

TCC-KS-EWN: wing nuts with AISI 303 stainless steel threaded stud, chamfered flat end UNI 947 - ISO 4753 (see Technical data on page), with black cap.

FEATURES AND APPLICATIONS

The clamping kit for TCC, comprising a distance bushing, an adjustable handle or a wing nut and nut, is used when clamping operations are required.



ELESA Original design

TCC-KS-ERX

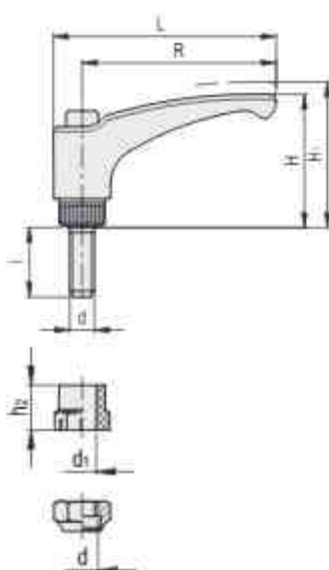

TCC-KS-EWN

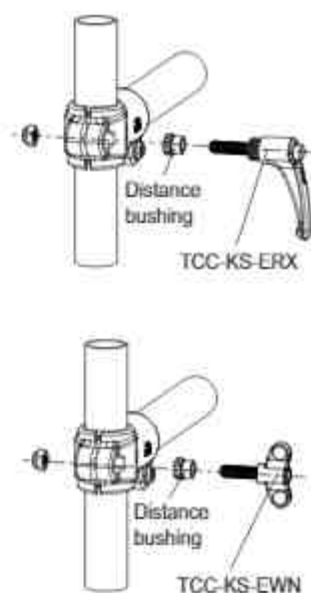
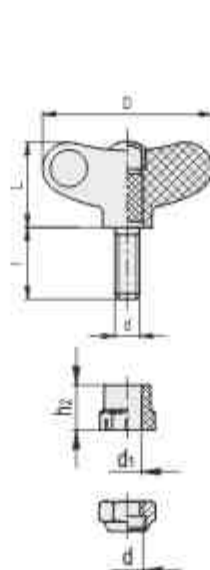

TCC-KS-ERX

STAINLESS STEEL

Code	Description	d	R	D	L	H	H1	h3	l	lt	For TCC	ΔL
600509 C1	TCC-KS-ERX.30 SST p-M6x30 C1	M6	30	15	37.5	30	33.5	23	30	9	TCC.18	21
600519 C1	TCC-KS-ERX.44 SST p-M6x30 C1	M6	44	16	52	32.5	36	25	30	11	TCC.18	23
600525 C1	TCC-KS-ERX.63 SST p-M6x30 C1	M6	63	19	72.5	43	47	34.5	30	13.5	TCC.18	25
600541 C1	TCC-KS-ERX.63 SST p-M8x40 C1	M8	63	19	72.5	43	47	34.5	40	13.5	TCC.30	47
600557 C1	TCC-KS-ERX.78 SST p-M8x40 C1	M8	78	23	89.5	54	58	44	40	16	TCC.30	56

TCC-KS-EWN

STAINLESS STEEL

Code	Description	d	D	L	b	l	For TCC	ΔL
600607 C1	TCC-KS-EWN.48 SST p-M6x30 C1	M6	47	24	7	30	TCC.18	18
600619 C1	TCC-KS-EWN.55 SST p-M8x40 C1	M8	55	28	8	40	TCC.30	36

Screws and nuts for TCC

Stainless steel

MATERIAL

AISI 304 stainless steel.

STANDARD EXECUTION

Cylindrical head screw with hexagon socket with anti seizure treatment and self-locking nut.

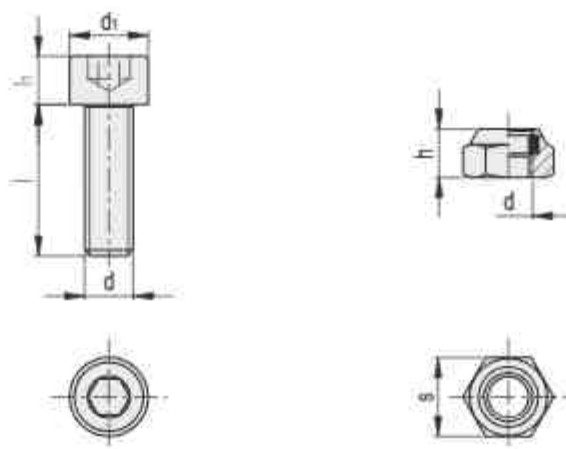

STAINLESS STEEL

Code	Description	d	d1	h	l	l1	s	Ⓢ
600706	TCC-KV M6	M6	10	6	18	6	10	8
600708	TCC-KV M8	M8	13	8	25	8	13	19

Mounting base for hinged joints

Technopolymer

BASE

Glass fibre reinforced polyamide based (PA) technopolymer, RAL 9005 (C9) black colour or grey RAL 7040 (C33) colour, matte finish.

SCREW AND NUT (SUPPLIED)

Cylindrical head screws with hexagon socket in AISI 304 stainless steel with anti seizure treatment.
Self locking nut in AISI 304 stainless steel.

STANDARD EXECUTIONS

TCC-PB-E: external teeth.
TCC-PB-S: without teeth.

FEATURES

A base with external teeth can be joined to a clamp with internal teeth, or a base without teeth to a clamp without teeth, to create a hinged joint.

Joints comprising bases with external teeth and clamps with internal teeth (30 teeth) have a 10° adjustment angle.

Joints comprising bases and clamps without teeth can be positioned at any angle.

The "s" grub screw may be replaced by the kit TCC-KS.



ELESA Original design

TECHNICAL DATA

The resistance values shown in the table were measured during laboratory tests at ambient temperature with the screws tightened to the maximum torque "C#".

ACCESSORIES ON REQUEST (TO BE ORDERED SEPARATELY)

TCC-KS (see page): clamping kit.
TCC-KV (see page): screws and clamping nuts.

TCC-PB-E

TCC-PB-S

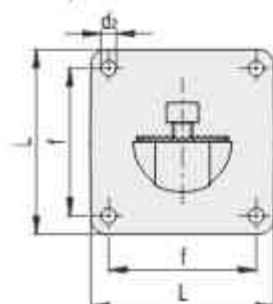
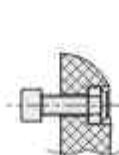
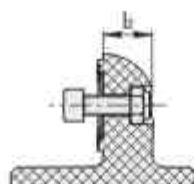
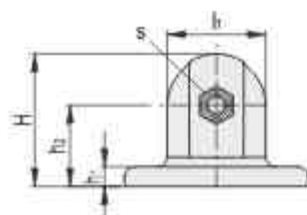

■ C9 RAL9005 ■ C33 RAL7040

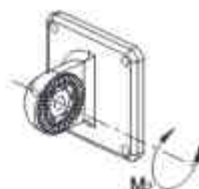

TCC-PB-E

STAINLESS STEEL

Code	Description	L	H	d2	F+0.2	h1	h2	t1	t2	s	C# [Nm]	M2*** [Nm]	⚙️
600421 C9	TCC PB 30 E C9	75	54	6.5	60	8	33	40	20	MS	12	100	78
600421 C33	TCC PB 30 E C33	75	54	6.5	60	8	33	40	20	MS	12	100	78

TCC-PB-S

STAINLESS STEEL

Code	Description	L	H	d2	F+0.2	h1	h2	t1	t2	s	C# [Nm]	M2*** [Nm]	⚙️
600425 C9	TCC PB 30 S C9	75	54	6.5	60	8	33	40	20	MS	12	7	73
600425 C33	TCC PB 30 S C33	75	54	6.5	60	8	33	40	20	MS	12	7	73

Suggested torque for screw assembly

*** Resistance to joint rotation.

Mounting base for hinged joints

Technopolymer

BASE

Glass fibre reinforced polyamide based (PA) technopolymer, RAL 9005 (C9) black colour or grey RAL 7040 (C33) colour, matte finish.

SCREW AND NUT (SUPPLIED)

Cylindrical head screws with hexagon socket in AISI 304 stainless steel with anti seizure treatment.

Self locking nut in AISI 304 stainless steel.

STANDARD EXECUTIONS

TCC-PBF-E: external teeth.

TCC-PBF-S: without teeth.

FEATURES

A base with external teeth can be joined to a clamp with internal teeth, or a base without teeth to a clamp without teeth, to create a hinged joint.

Joints comprising bases with external teeth and clamps with internal teeth (30 teeth) have a 10° adjustment angle.

Joints comprising bases and clamps without teeth can be positioned at any angle.

The "s" grub screw may be replaced by the kit TCC-KS.

TECHNICAL DATA

The resistance values shown in the table were measured during laboratory tests at ambient temperature with the screws tightened to the maximum torque "C#".



ELESA Original design

ACCESSORIES ON REQUEST (TO BE ORDERED SEPARATELY)

TCC-KS (see page): clamping kit.

TCC-KV (see page): screws and clamping nuts.

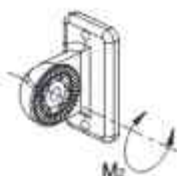
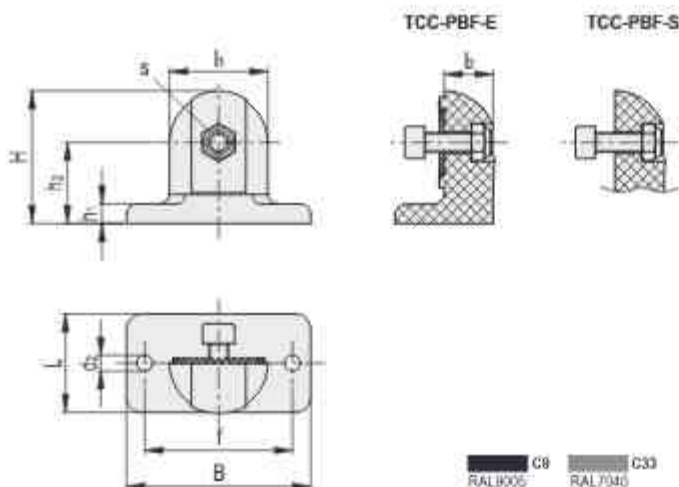

TCC-PBF-E

STAINLESS STEEL

Code	Description	L	B	H	d2	F±0.2	ht	ht2	lt	lt2	s	C# [Nm]	M2*** [Nm]	🔩
600431 C9	TCC-PBF 30 E C9	40	75	54	6.5	60	8	33	40	20	M8	12	100	63
600431 C33	TCC-PBF 30 E C33	40	75	54	6.5	60	8	33	40	20	M8	12	100	63

TCC-PBF-S

STAINLESS STEEL

Code	Description	L	B	H	d2	F±0.2	ht	ht2	lt	lt2	s	C# [Nm]	M2*** [Nm]	🔩
600435 C9	TCC-PBF 30 S C9	40	75	54	6.5	60	8	33	40	20	M8	12	7	58
600435 C33	TCC-PBF 30 S C9	40	75	54	6.5	60	8	33	40	20	M8	12	7	58

Suggested torque for screw assembly

*** Resistance to joint rotation.

Connecting clamps with sleeve

Technopolymer

CLAMP

Glass fibre reinforced polyamide based (PA) technopolymer, RAL 9005 (C9) black colour or grey RAL 7040 (C33) colour, matte finish.

SCREWS AND NUTS (SUPPLIED)

Cylindrical head screw with hexagon socket in AISI 304 stainless steel with anti seizure treatment.

Self locking nuts in AISI 304 stainless steel.

FEATURES

Clamps for tubes with a diameter of 18 ± 0.2 and 30 ± 0.2 mm.

For smaller diameter tubes, the hole reduction sleeve TCC A can be used (ordered separately).

The "s" grub screws may be replaced by the kit TCC KS.

TECHNICAL DATA

The resistance values shown in the table were measured during laboratory tests at ambient temperature with the screws tightened to the maximum torque "C#".

ACCESSORIES ON REQUEST (TO BE ORDERED SEPARATELY)

TCC A (see page): reduction sleeves.

TCC KS (see page): clamping kit.

TCC KV (see page): screws and clamping nuts.

GN 990 (see page): connecting tubes.



ELESA Original design



TCC-KS-ERX



TCC-KS-EWN

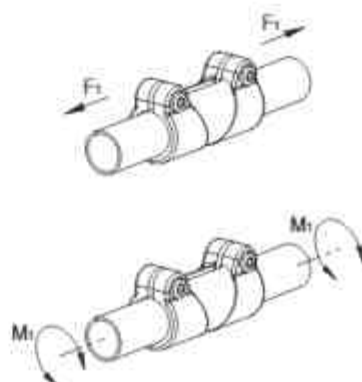
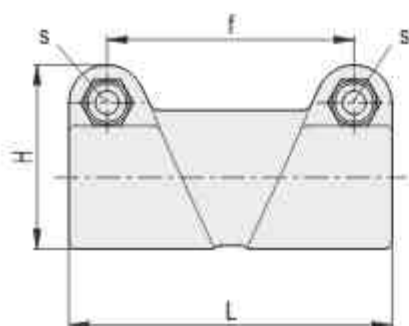

C9
 C33
 RAL9005 RAL7040

STAINLESS STEEL

Code	Description	d	L	H	f	b	la	s	C# [Nm]	F1* [N]	M1** [Nm]	σ _{0.2}
600131 C9	TCC SL 18 18 C9	18	64.5	35.5	48	20.5	29	M6	5	1100	13	45
600131 C33	TCC SL 18 18 C33	18	64.5	35.5	48	20.5	29	M6	5	1100	13	45
600231 C9	TCC SL 30 30 C9	30	94.5	53.5	72	27	42	M8	12	1400	25	116
600231 C33	TCC SL 30 30 C33	30	94.5	53.5	72	27	42	M8	12	1400	25	116

Suggested torque for screw assembly

* Resistance to tube pull out

** Resistance to tube rotation

Connecting clamps with mounting plate

Technopolymer

CLAMP

Glass fibre reinforced polyamide based (PA) technopolymer, RAL 9005 (C9) black colour or grey RAL 7040 (C33) colour, matte finish.

SCREW AND NUT (SUPPLIED)

Cylindrical head screws with hexagon socket in AISI 304 stainless steel with anti seizure treatment.

Self locking nut in AISI 304 stainless steel.

FEATURES

Clamps for tubes with a diameter of 18 ± 0.2 and 30 ± 0.2 mm.

For smaller diameter tubes, the hole reduction sleeve TCC A can be used (ordered separately).

The "s" grub screw may be replaced by the kit TCC-KS.

TECHNICAL DATA

The resistance values shown in the table were measured during laboratory tests at ambient temperature with the screws tightened to the maximum torque "C#".

ACCESSORIES ON REQUEST (TO BE ORDERED SEPARATELY)

TCC A (see page -): reduction sleeves.

TCC-KS (see page -): clamping kit.

TCC-KV (see page -): screws and clamping nuts.

GN 990 (see page -): connecting tubes.



ELESA Original design

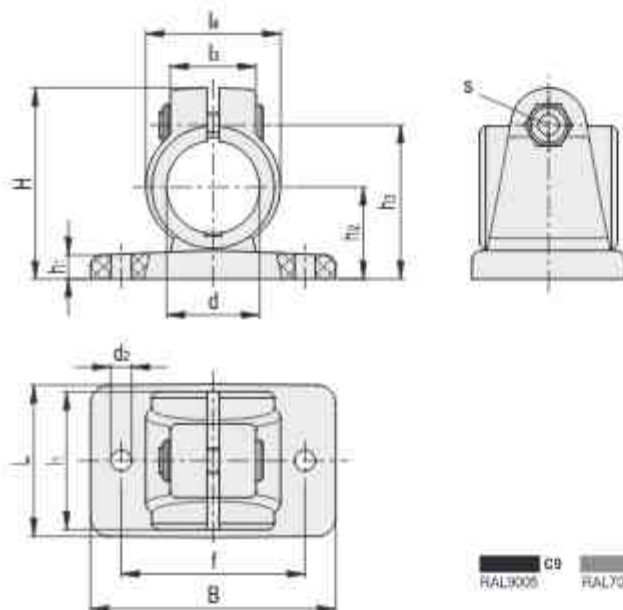
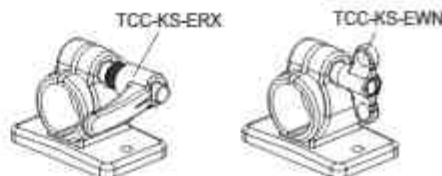

■ C9 RAL9005 ■ C33 RAL7040

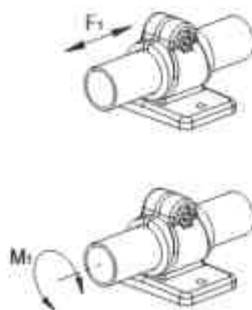

STAINLESS STEEL

Code	Description	d	L	B	H	d2	f±0.2	h1	h2	h3	t1	t3	t4	s	C# [Nm]	F1* [N]	M1** [Nm]	σ _{0.2}
600141 C9	TCC-TB-18-C9	18	34.5	52	41	5.3	40	5	18	33.5	29	21	29	M6	5	1450	16	29
600141 C33	TCC-TB-18-C33	18	34.5	52	41	5.3	40	5	18	33.5	29	21	29	M6	5	1450	16	29
600241 C9	TCC-TB-30-C9	30	49.5	80	61.5	6.5	60	8	30	50	44.5	27	44	M8	12	1800	27	84
600241 C33	TCC-TB-30-C33	30	49.5	80	61.5	6.5	60	8	30	50	44.5	27	44	M8	12	1800	27	84

Suggested torque for screw assembly

* Resistance to tube pull out

** Resistance to tube rotation

Clamps for hinged joints

Technopolymer

CLAMP

Glass fibre reinforced polyamide based (PA) technopolymer, RAL 9005 (C9) black colour or grey RAL 7040 (C33) colour, matte finish.

SCREWS AND NUTS

Cylindrical head screw with hexagon socket in AISI 304 stainless steel with anti seizure treatment.

Self locking nuts in AISI 304 stainless steel.

Supplied: two screws and two nuts for versions TCC-TP-E and TCC-TP-S, one screw and one nut for version TCC-TP-I.

STANDARD EXECUTIONS

TCC-TP-E: external teeth.

TCC-TP-I: internal teeth.

TCC-TP-S: without teeth.

FEATURES

Two clamps, one with external teeth and one with internal teeth or two without teeth, can be joined to create a hinged joint.

Joints comprising clamps with external/internal teeth (36 teeth) have a 10° adjustment angle.

Joints comprising clamps without teeth can be positioned at any angle.

Clamps for tubes with a diameter of 30 ± 0.2 mm.

For smaller diameter tubes, the hole reduction sleeve can be used TCC-A (to be ordered separately).

The "s" grub screws may be replaced by the kit TCC-KS.

TECHNICAL DATA

The resistance values shown in the table were measured during laboratory tests at ambient temperature with the screws tightened to the maximum torque "C#".

ACCESSORIES ON REQUEST (TO BE ORDERED SEPARATELY)

TCC-A (see page): reduction sleeves.

TCC-KS (see page): clamping kit.

GN 197 (see page): monitor mounts.

TCC-KV (see page): screws and clamping nuts.

GN 990 (see page): connecting tubes.



ELESA Original design



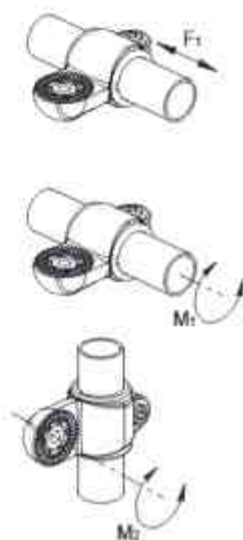
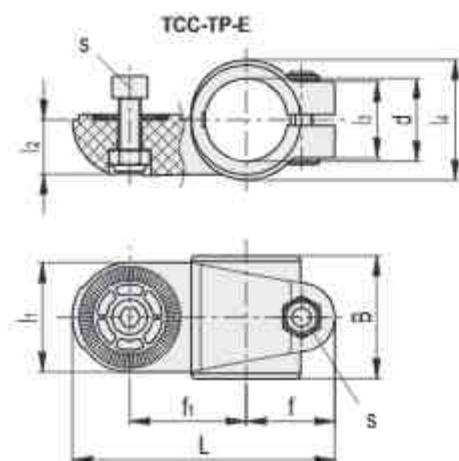

TCC-TP-E

STAINLESS STEEL

Code	Description	d	L	B	f	ft	lt	lz	Bz	H	s	C#	F1*	M1**	M2***	⚙
												[Nm]	[N]	[Nm]	[Nm]	
600411 C9	TCC TP 30 E C9	30	95	44.5	32.5	42	40	16.5	27	44	M8	12	3000	33	120	83
600411 C33	TCC TP 30 E C33	30	95	44.5	32.5	42	40	16.5	27	44	M8	12	3000	33	120	83

TCC-TP-I

STAINLESS STEEL

Code	Description	d	L	B	d2	f	ft	lt	lz	Bz	H	s	C#	F1*	M1**	M2***	⚙
													[Nm]	[N]	[Nm]	[Nm]	
600413 C9	TCC TP 30 I C9	30	95	44.5	8.1	32.5	42	40	16.5	27	44	M8	12	3000	33	120	82
600413 C33	TCC TP 30 I C33	30	95	44.5	8.1	32.5	42	40	16.5	27	44	M8	12	3000	33	120	82

TCC-TP-S

STAINLESS STEEL

Code	Description	d	L	B	f	ft	lt	lz	Bz	H	s	C#	F1*	M1**	M2***	⚙
												[Nm]	[N]	[Nm]	[Nm]	
600415 C9	TCC TP 30 S C9	30	95	44.5	32.5	42	40	16.5	27	44	M8	12	3000	33	4	82
600415 C33	TCC TP 30 S C33	30	95	44.5	32.5	42	40	16.5	27	44	M8	12	3000	33	4	82

Suggested torque for screw assembly.

* Resistance to tube pull out.

** Resistance to tube rotation.

*** Resistance to joint rotation.

Hinged joint with mounting base and clamp

Technopolymer

CLAMP AND BASE

Glass fibre reinforced polyamide based (PA) technopolymer, RAL 9005 (C9) black colour or grey RAL 7040 (C33) colour, matte finish.

SCREWS AND NUTS (SUPPLIED)

Cylindrical head screw with hexagon socket in AISI 304 stainless steel with anti seizure treatment.
Self locking nuts in AISI 304 stainless steel.

STANDARD EXECUTIONS

- TCC-TP-PB-T: with teeth
- TCC-TP-PB-S: without teeth

FEATURES

Joints comprising bases with external teeth and clamps with internal teeth (36 teeth) have a 10° adjustment angle.
Joints comprising bases and clamps without teeth can be positioned at any angle.
Clamps for tubes with a diameter of 30 ± 0.2 mm.
For smaller diameter tubes, the hole reduction sleeve can be used TCC A (to be ordered separately).
The "s" grub screws may be replaced by the kit TCC-KS.

TECHNICAL DATA

The resistance values shown in the table were measured during laboratory tests at ambient temperature with the screws tightened to the maximum torque "C#".

ACCESSORIES ON REQUEST (TO BE ORDERED SEPARATELY)

- TCC A (see page -): reduction sleeves.
- TCC-KS (see page -): clamping kit.
- GN 197 (see page -): monitor mounts.
- TCC-KV (see page -): screws and clamping nuts.
- GN 990 (see page -): connecting tubes.



ELESA Original design



TCC-KS-ERX

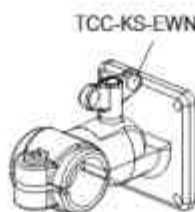

TCC-KS-EWN

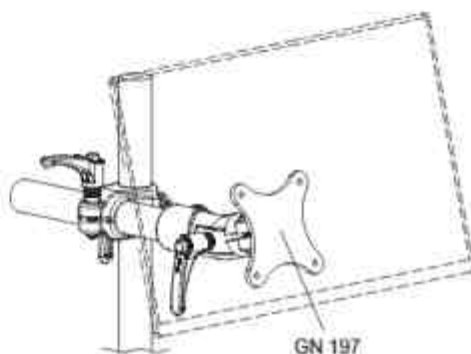

GN 197

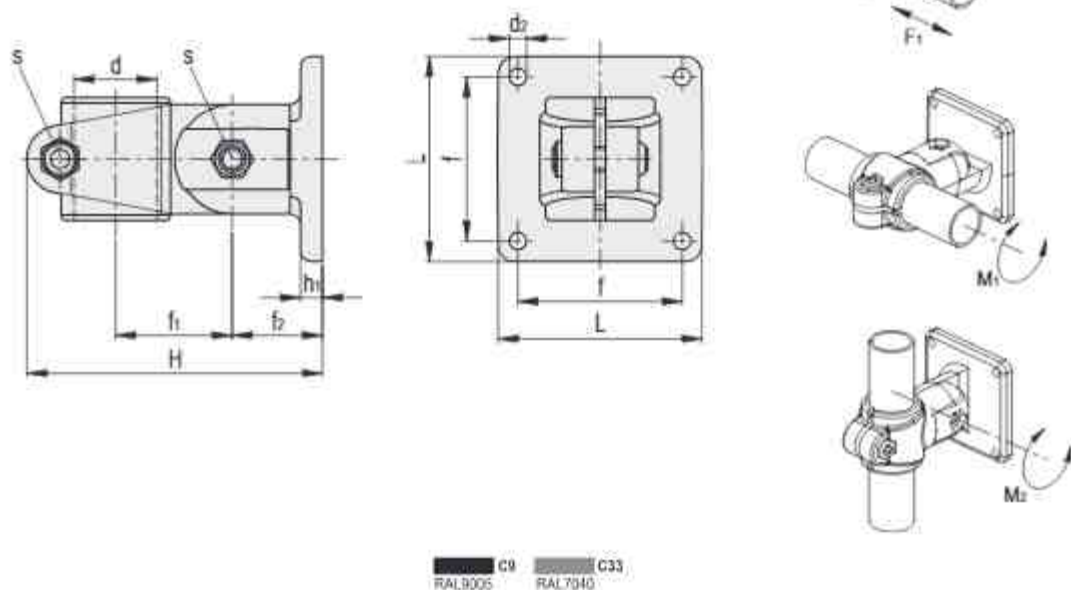

TCC-TP-PB-T

STAINLESS STEEL

Code	Description	d	L	H	d2	f±0.2	f1	f2	h0	s	C#	F1*	M1**	M2***	⊕
											[Nm]	[N]	[Nm]	[Nm]	
600841 C9	TCC-TP-PB-30-T-C9	30	75	108	65	60	42	33	8	M8	12	3000	33	100	160
600841 C33	TCC-TP-PB-30-T-C33	30	75	108	65	60	42	33	8	M8	12	3000	33	100	160

TCC-TP-PB-S

STAINLESS STEEL

Code	Description	d	L	H	d2	f±0.2	f1	f2	h0	s	C#	F1*	M1**	M2***	⊕
											[Nm]	[N]	[Nm]	[Nm]	
600842 C9	TCC-TP-PB-30-S-C9	30	75	108	65	60	42	33	8	M8	12	3000	33	4	160
600842 C33	TCC-TP-PB-30-S-C33	30	75	108	65	60	42	33	8	M8	12	3000	33	4	160

Suggested torque for screw assembly.

* Resistance to tube pull out.

** Resistance to tube rotation.

*** Resistance to joint rotation.

Hinged joint with mounting base and clamp

Technopolymer

CLAMP AND BASE

Glass fibre reinforced polyamide based (PA) technopolymer, RAL 9005 (C9) black colour or grey RAL 7040 (C33) colour, matte finish.

SCREWS AND NUTS (SUPPLIED)

Cylindrical head screw with hexagon socket in AISI 304 stainless steel with anti seizure treatment.

Self locking nuts in AISI 304 stainless steel.

STANDARD EXECUTIONS

TCC-TP-PBF-T: with teeth.

TCC-TP-PBF-S: without teeth.

FEATURES

Joints comprising bases with external teeth and clamps with internal teeth (36 teeth) have a 10° adjustment angle.

Joints comprising bases and clamps without teeth can be positioned at any angle.

Clamps for tubes with a diameter of 30 ± 0.2 mm.

For smaller diameter tubes, the hole reduction sleeve can be used TCC A (to be ordered separately).

The "s" grub screws may be replaced by the kit TCC-KS.

TECHNICAL DATA

The resistance values shown in the table were measured during laboratory tests at ambient temperature with the screws tightened to the maximum torque "C#".

ACCESSORIES ON REQUEST (TO BE ORDERED SEPARATELY)

TCC A (see page -): reduction sleeves.

TCC-KS (see page -): clamping kit.

GN 197 (see page -): monitor mounts.

TCC-KV (see page -): screws and clamping nuts.

GN 990 (see page -): connecting tubes.



ELESA Original design

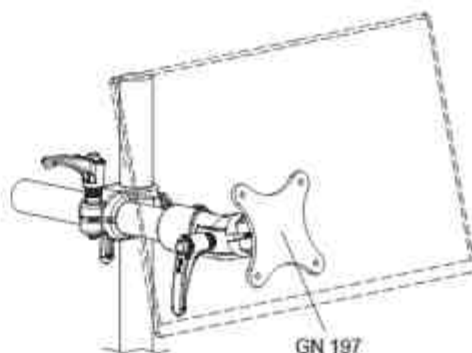
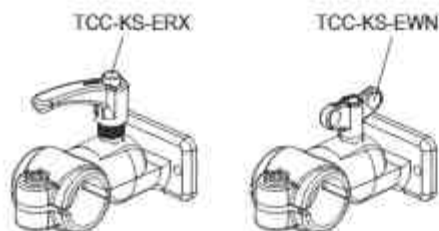

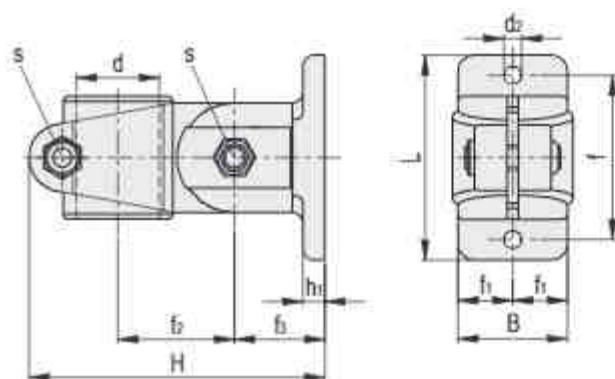

TCC-TP-PBF-T

STAINLESS STEEL

Code	Description	d	L	B	H	d2	f ±0.2	f1	f2	f3	h1	ϕ	C#	F1*	M1**	M2***	⊕	
														[Nm]	[N]	[Nm]	[Nm]	
600851 C9	TCC TP-PBF 30-T C9	30	75	40	108	6.5	60	20	42	33	8	M8	12	3000	33	100	145	
600851 C33	TCC TP-PBF 30-T C33	30	75	40	108	6.5	60	20	42	33	8	M8	12	3000	33	100	145	

TCC-TP-PBF-S

STAINLESS STEEL

Code	Description	d	L	B	H	d2	f ±0.2	f1	f2	f3	h1	ϕ	C#	F1*	M1**	M2***	⊕	
														[Nm]	[N]	[Nm]	[Nm]	
600852 C9	TCC TP-PBF 30-S C9	30	75	40	108	6.5	60	20	42	33	8	M8	12	3000	33	4	145	
600852 C33	TCC TP-PBF 30-S C33	30	75	40	108	6.5	60	20	42	33	8	M8	12	3000	33	4	145	

Suggested torque for screw assembly.

* Resistance to tube pull out.

** Resistance to tube rotation.

*** Resistance to joint rotation.

T-shaped connecting clamps

Technopolymer

CLAMP

Glass fibre reinforced polyamide based (PA) technopolymer, RAL 9005 (C9) black colour or grey RAL 7040 (C33) colour, matte finish.

SCREWS AND NUTS (SUPPLIED)

Cylindrical head screw with hexagon socket in AISI 304 stainless steel with anti seizure treatment.

Self locking nuts in AISI 304 stainless steel.

FEATURES

Clamps for tubes with a diameter of 18 ± 0.2 and 30 ± 0.2 mm.

For smaller diameter tubes, the hole reduction sleeve TCC A can be used (ordered separately).

The "s" grub screws may be replaced by the kit TCC KS.

TECHNICAL DATA

The resistance values shown in the table were measured during laboratory tests at ambient temperature with the screws tightened to the maximum torque "C#".

ACCESSORIES ON REQUEST (TO BE ORDERED SEPARATELY)

TCC A (see page): reduction sleeves.

TCC KS (see page): clamping kit.

TCC KV (see page): screws and clamping nuts.

GN 990 (see page): connecting tubes.



ELESA Original design

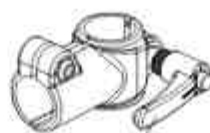

TCC-KS-ERX



TCC-KS-EWN

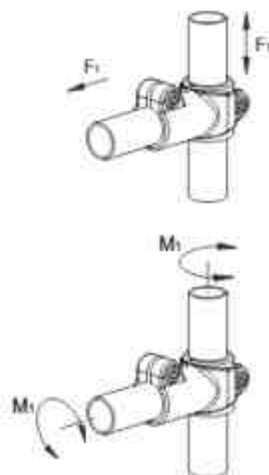
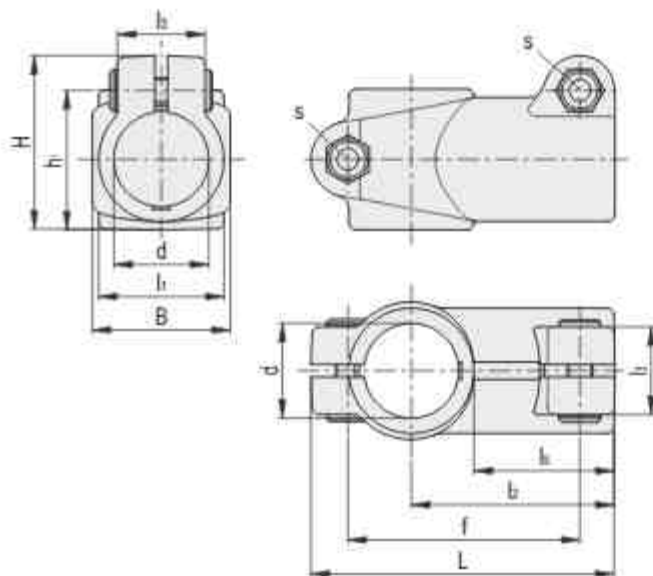

STAINLESS STEEL

Code	Description	d	L	B	H	f	ht	lt	lz	ts	ts'	s	C#	F1*	M1**	σ
													[Nm]	[N]	[Nm]	
600151 C9	TCC TS 18 18 C9	18	65	29	35	49	27	26.5	43.5	20.5	30.5	M6	5	1450	14	42
600151 C33	TCC TS 18 18 C33	18	65	29	35	49	27	26.5	43.5	20.5	30.5	M6	5	1450	14	42
600251 C9	TCC TS 30 30 C9	30	96	44	55.5	74	44	40.5	64.5	28	45.5	M8	12	1650	17	113
600251 C33	TCC TS 30 30 C33	30	96	44	55.5	74	44	40.5	64.5	28	45.5	M8	12	1650	17	113

Suggested torque for screw assembly

* Resistance to tube pull out

** Resistance to tube rotation